



Guided Radar: VEGAFLEX series 80

VEGAFLEX series 80: Simple, reliable and versatile

You can use the new series 80 VEGAFLEX in almost any level or interface measurement application. Its standardized adjustment and operation is quick and easy to learn and ensures measurement certainty and high reliability.

The advantages of guided radar

Microwave pulses are guided along a cable or rod probe and reflected by the product surface. Their running time is proportional to the level. Buildup, steam or dust are completely ignored by VEGAFLEX. All important sensor parameters are preset at the factory. If necessary, the length of non-coated cable and rod versions can be easily adapted to your specific application. Measuring solids, liquids and interfaces is simpler and more reliable than ever.

Versatile and perfectly fitting

The VEGAFLEX 80 instrument series is clearly divided into specific areas of application. This allows easier and clearer instrument selection. Whether for liquids or solids, in each and every case you'll find an instrument optimized for your application.

An intelligent adjustment system allows for easy, time saving setup and commissioning. Even the decision as to whether the level or the interface, or both, are to be measured, is made during the setup process. All instruments are capable of measuring either.



“You get your instrument with all parameters preset, exactly as requested. In many applications, VEGAFLEX 80 needs no additional configuration. This means installation, setup and commissioning are carried out quickly and easily.”



VEGAFLEX series 80

- The universally applicable measuring principle simplifies project planning
- The free choice between level and interface measurement, regardless of sensor type, optimizes instrument selection and stocking
- Simple, intuitive setup saves costs and gets the system up and running quickly
- The intelligent, self-learning electronic deliver reliable measurement data, making the entire plant more secure

VEGAFLEX in the plics[®] system





Trend-setting measurement technology orientates itself around the people who use it. That's why we developed plics® – the world's first modular product system for instrumentation. Every one of our sensors is custom built from plics® components and so it can fulfill the requirements of your measurement application down to the last detail.

Simpler planning with plics®

The many possible combinations of sensor, process fitting, electronics and housing simplify instrument selection and project planning. Cost reduction with plics® thus starts already in the planning stage.

Clear advantages in setup and commissioning

Short delivery times, uncomplicated connection, fast setup save time and money. Configuration, wiring and setup of all plics® instruments are always the same. This considerably shortens the time required for training employees as well as putting new measuring points into service.

Greater reliability in operation

plics® instruments deliver a convincing performance in everyday operation thanks to high operational reliability, simplified maintenance and reduced replacement part stocks. The consistency of the technology and handling simplifies and accelerates work with the sensors. Whether performed directly on the instrument with the indicating and adjustment module PLICSCOM or via a PC in the control room, the simple, menu-driven adjustment procedures are identical on all instruments. This saves time and money in training the technical staff.

The plics® advantages

As a plics® sensor, VEGAFLEX 80 utilises all the advantages a modular concept has to offer:

- Housing of plastic, aluminium or stainless steel
- Multiple process fittings and materials
- Standardised electrical connection concept
- Fast setup and commissioning via application-specific menus
- Data and event memory for service and diagnostics
- Simple electronics exchange

VEGAFLEX for liquids

The all-rounder for every medium

VEGAFLEX 81 is as versatile as the applications in liquids are multifaceted and diverse. From raw materials storage to processing, to the storage of finished products – VEGAFLEX 81 always delivers reliable measurement data. In addition, to making the continuous measurement required, the intelligent data processing system also dynamically adapts itself to the changing process conditions. This ensures accuracy and reliability for level measurement in liquids.

- Versatile probe designs can also be shortened to suit the process and application
- The ability to switch over from level to interface measurement simplifies instrument selection and equipment design
- Functional safety up to SIL 2/3 according to IEC 61508

VEGAFLEX 81 – Main features at a glance

Process temperature:	-40 ... +200 °C
Process pressure:	-1 ... +40 bar
Measuring accuracy:	+/- 2 mm
Process fittings:	Threads from 3/4", 3/4 NPT Flanges from DN 25, 1"
Meas. range up to 6 m:	Rod probe (exchangeable) Coaxial probe Coaxial probe for ammonia
Meas. range up to 32 m:	Cable probe (exchangeable)
Meas. range up to 75 m:	Cable probe (exchangeable)



Level measurement in a storage tank

- For all liquid media
- Unaffected by foam, buildup and steam
- Special version for ammonia

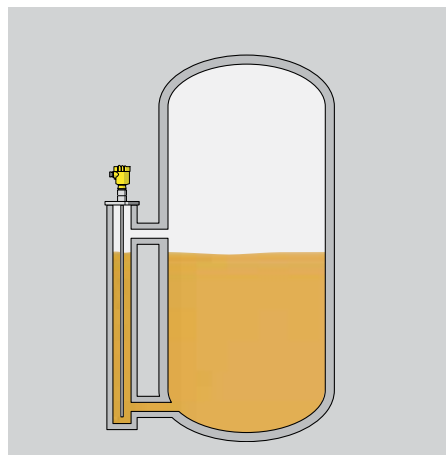

Level measurement in a bypass/standpipe

- Very high accuracy
- Simple retrofit to existing installations
- Can be supplied assembled into VEGAPASS 81 bypass chamber

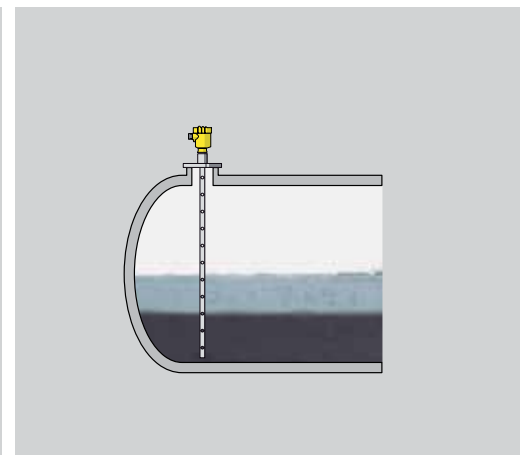

Interface measurement

- Available for all instruments
- Optionally available with second current output



The “tough one” for extreme conditions

Wherever extremely high or low temperatures or high pressures exist in your processes, VEGAFLEX 86 is the right choice. Its robust construction and dual seal ensure the integrity of the sensor and your process.

VEGAFLEX 86 features automatic transit time correction especially for applications with saturated steam in steam boilers. This gives you more accurate and reliable measurements in every phase of operation.

- Automatic probe monitoring increases system security
- The second process seal (Second Line of Defense) protects employees and production facilities
- Functional safety up to SIL 2/3 according to IEC 61508

VEGAFLEX 86 – Main features at a glance

Process temperature:	-196 ... +450 °C
Process pressure:	-1 ... +400 bar
Measuring accuracy:	+/- 2 mm
Process fittings:	Threads from 1½", 1½" NPT Flanges from DN 50, 2"
Meas. range up to 6 m:	Rod probe (exchangeable) Coaxial probe
Meas. range up to 75 m:	Cable probe (exchangeable)

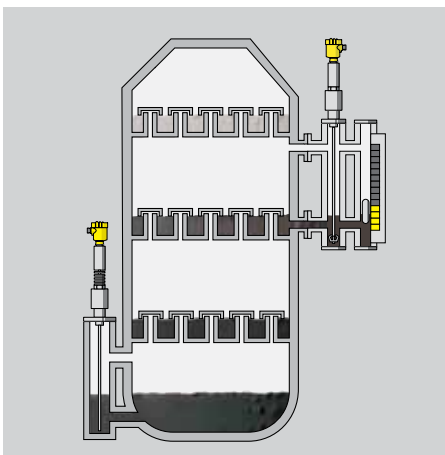

Measurement in a distillation column

- Easy retrofit to existing bypasses
- Level and interface measurement selectable on all instruments
- For use in protective equipment

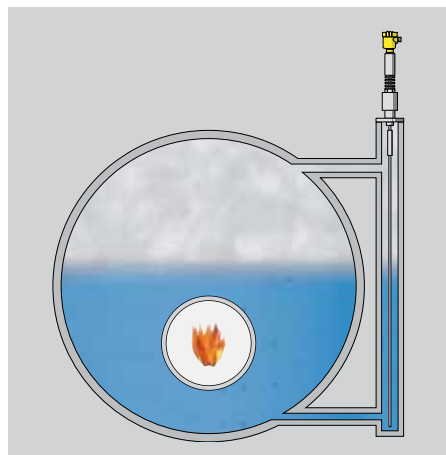

Level measurement in a steam boiler

- With automatic measurement correction in saturated steam
- Implementable as limiting device
- Suitable for 72 hours of unattended operation

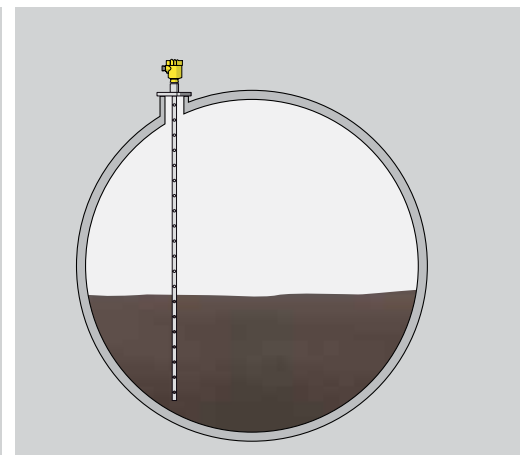

Level measurement in a gas tank (LPG)

- Independent of gas temperature
- With coaxial probe for highest accuracy

VEGAFLEX for special applications

The specialist for hygiene and chemicals

In food and pharmaceutical products, cleanliness and hygiene are paramount. With its rod probe of high-grade stainless steel, VEGAFLEX 83 provides an absolutely clean solution for your sensitive media. Its stainless steel housing with protection rating IP 69K resists any intensive cleaning on the outside of the vessel. With the autoclave version, you can remove the instrument housing from the sensor in just a few simple steps. The PFA and PTFE coated sensor withstands all aggressive media.

- The hygienic design (IP 69K and $R_a \leq 0.8 \mu\text{m}$) allows thorough, reliable cleaning
- Unrestricted measuring range allows use even in small containers
- Functional safety up to SIL 2/3 according to IEC 61508

VEGAFLEX 83 – Main features at a glance

Process temperature:	-40 ... +150 °C
Process pressure:	-1 ... +16 bar
Measuring accuracy:	+/- 2 mm
Approvals:	FDA, 3A, EHEDG
Process fittings:	Hygienic fittings Plated flanges from DN 25, 2"
Meas. range up to 4 m:	Rod probe (coated)
Meas. range up to 6 m:	Rod probe (uncoated, exchangeable)
Meas. range up to 32 m:	Cable probe (coated)

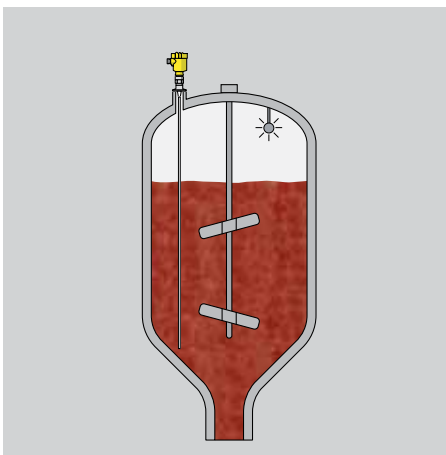

Level measurement in a ketchup mixer

- Independent of product buildup
- Can be used in small vessels

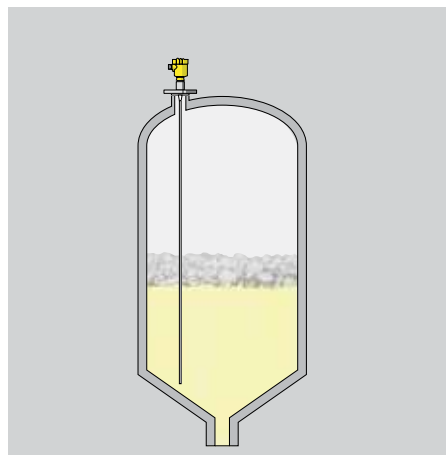

Level measurement in a milk tank

- Unaffected by foam generation
- Standard hygienic process fittings

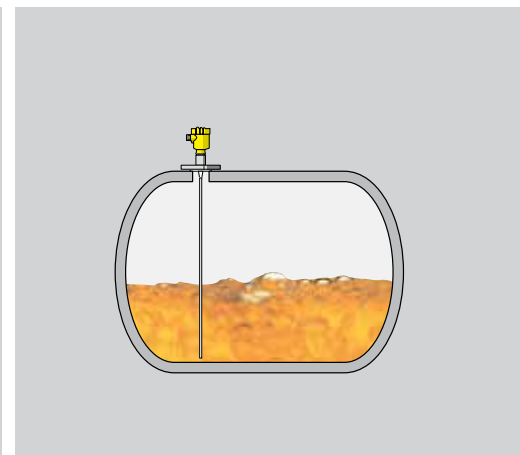

Level measurement in an acid container

- Unaffected by aggressive vapours
- Independent of product buildup
- High accuracy



The robust sensor for bulk solids

VEGAFLEX 82 is specially designed for bulk solids applications. Its self-learning signal analyses and detects dust or product buildup automatically. This always guarantees dependable measuring results. Continuous probe condition monitoring ensures even greater operational safety and reliability in your plant.

- After the probe is exchanged or shortened, the electronics determines its new length at the press of a button
- Delivery with factory settings makes setup and commissioning fast and effective
- Functional safety up to SIL 2/3 according to IEC 61508

VEGAFLEX 82 – Main features at a glance

Process temperature:	-40 ... +200 °C
Process pressure:	-1 ... +40 bar
Measuring accuracy:	+/- 2 mm
Process fittings:	Threads from 3/4", 3/4 NPT Flanges from DN 25, 1"
Meas. range up to 6 m:	Rod probe (exchangeable)
Meas. range up to 75 m:	Cable probe (exchangeable)

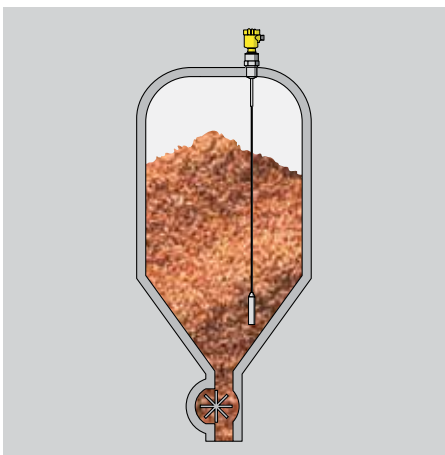

Level measurement in a grain silo

- Wear resistant probe designs
- Independent of dust and buildup

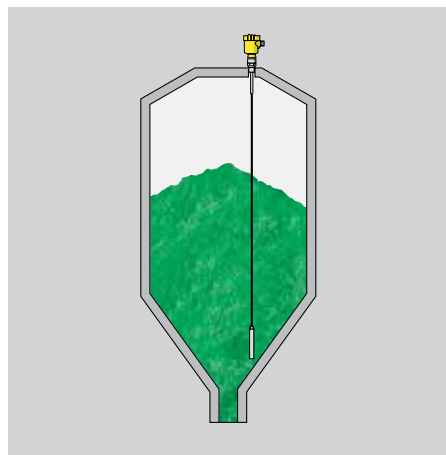

Level measurement in plastics

- High measurement certainty in powders and granulates via probe end tracking
- Unaffected by noise, dust and product buildup



Level measurement in a cement silo

- Reliable even with heavy product buildup
- Unaffected by extremely dusty conditions

Setup and maintenance practically take care of themselves



“Decades of experience have been incorporated into this instrument operating system. The self-learning electronics requires only a few settings. Setup and commissioning of a level measuring point has never been this fast and reliable.”

To maintain high plant productivity, every minute counts during the setup and maintenance of a measuring point. Simple, straightforward instrument operation is vital here. The intelligent operating system of VEGAFLEX series 80 allows you to carry out fast setup and commissioning, predictive maintenance and reliable diagnostics.

PLICSCOM, the multi-function talent

The indicating and adjustment module PLICSCOM is used for measured value indication, adjustment and sensor diagnostics. Its menu structure is simple and allows a really fast instrument setup. Status messages are displayed in plain text.

Adjustment with PC or control system

The mobile VEGACONNECT is used to connect your VEGA instrument with your PC via the USB port. Parameterization of the instrument is carried out via the proven adjustment software PACTware and a DTM. For EDD-based adjustment, we also offer graphically supported EDDs.

By the way, you can also use VEGACONNECT as a universal HART modem for sensors from other manufacturers.

Recognising maintenance requirements early

The integrated self-monitoring of plics® instruments keeps you informed about the status of your instrument at all times. The status messages as per NE 107/VDI/VDE 2650 allow predictive, cost-saving maintenance. Via the built-in memory functions you can quickly and easily call up all diagnostic data in plain, readable text. These are provided with a real-time stamp and encompass the complete history of your measuring point.

- Predictive maintenance through plain text display of instrument status
- Seamless tracking via extensive data memory for measured values and events
- The continuous operation of your facility is guaranteed through the simple, non-interrupting, three-step function test in accordance with SIL

Event memory (List of the parameter changes and event in the instrument)

Graph:

Date/Time	Status	Event type	Event description	Value/Extended status
18.06.2012 06:11:21	Outgoing	800	Supply voltage switched on	0
18.06.2012 05:48:12	Incoming	801	Supply voltage switched off	0
15.06.2012 09:14:22	Change	By PC (directly)	Distance B (min.-adjustment)	1750 mm
15.06.2012 09:12:06	Change	By PC (directly)	Automatic length determination	1760 mm
15.06.2012 09:03:05	Outgoing	M506 (Maintenance required)	Signal damping	12300
14.06.2012 23:38:32	Incoming	M506 (Maintenance required)	Signal damping	12300
12.06.2012 13:22:48	Outgoing	S601 (Out of Specification)	Over spill	15100
12.06.2012 11:48:10	Incoming	S601 (Out of Specification)	Over spill	15100
01.06.2012 17:01:13	Change	By adjustment module	Lighting	On
01.06.2012 08:34:41	Outgoing	C700 (Function check)	Simulation active	4005
01.06.2012 08:31:18	Incoming	C700 (Function check)	Simulation active	4005
01.06.2012 08:28:57	Change	By PC (directly)	Medium / Dielectric constant	Solvents, Liquefied gases, Oils / < 3
01.06.2012 08:28:12	Change	By PC (directly)	Distance B (min.-adjustment)	1750 mm
01.06.2012 08:27:43	Change	By PC (directly)	Distance A (max.-adjustment)	50 mm

Event memory with Asset Management status



VEGA Grieshaber KG
Am Hohenstein 113
77761 Schiltach
Germany

Phone +49 7836 50-0
Fax +49 7836 50-201
E-mail info.de@vega.com
www.vega.com

Looking Forward **VEGA**