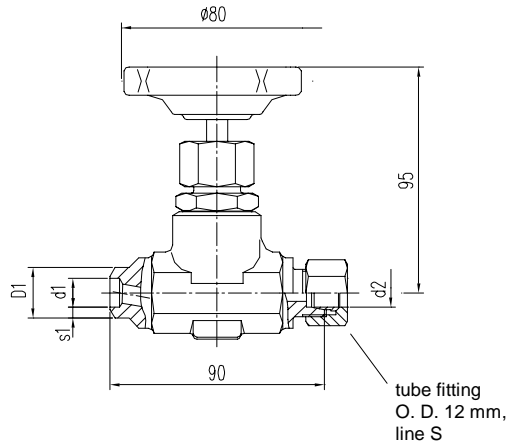
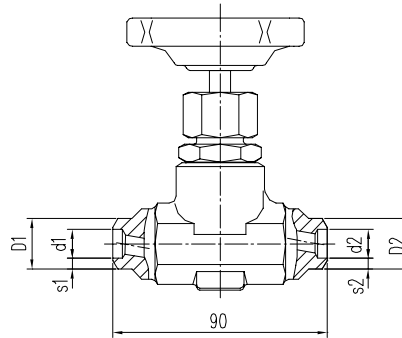
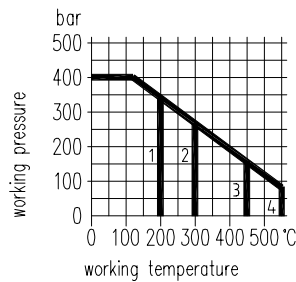
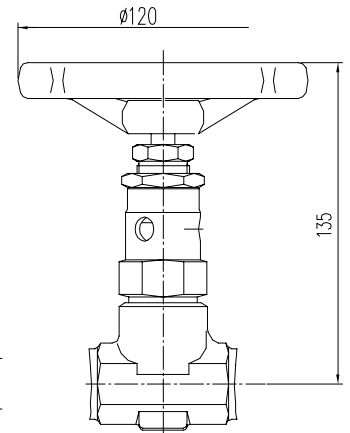

Type 1

Type 2

Type with external stem thread

- 1 PTFE packing
- 2 graphite packing - internal stem thread
- 3 graphite packing - external stem thread - 1.0460
- 4 graphite packing - external stem thread - 1.4571

Type	Material	Connections						Part no. for shut-off valve with	
		D 1	d 1	S 1	D 2	d 2	S 2	internal stem thread	external stem thread
1	steel st. st.	21,3	12,2	-	-	12	-	S350.05.130 S350.05.230	S351.05.130 S351.05.230
	steel st. st.	24	-	7,1	-	12	-	S350.05.130.09 S350.05.230.09	S351.05.130.09 S351.05.230.09
2	steel st. st.	21,3	12,2	-	21,3	12,2	-	S350.05.100 S350.05.200	S351.05.100 S351.05.200
	steel st. st.	24	-	7,1	14	-	2,5	S350.05.130.23 S350.05.230.23	S351.05.130.23 S351.05.230.23

Components	Internal stem thread		External stem thread	
	Steel	Stainless steel ¹⁾	Steel	Stainless steel ¹⁾
	DIN - Material Number			
Body ²⁾	1.0460	1.4571	1.0460	1.4571
Bonnet	1.0501	1.4571	1.7709	1.4571
Valve seat	1.4021	1.4571	1.4021	1.4571
Valve stem	1.4104	1.4571	1.4021	1.4571
Needle tip	1.4122 ⁷⁾	1.4571	1.4122 ⁷⁾	1.4571
Packing	graphite up to 300°C	PTFE up to 200°C ⁴⁾	graphite up to 450°C ⁴⁾	PTFE up to 200°C ^{5) 6)}
Union nut / gland nut	steel	1.4571	-	-
	-	-	2.0550	1.4301
Handwheel	plastic ³⁾		steel	

- **Body:** die-pressed part
- **Surface:** steel phosphatized
- Internal or external stem thread
- Replaceable valve seat
- Stem with cold rolled surface, back seat and non-rotating needle tip
- Special types are available

- 1) Can also be supplied for oxygen service. Please notice order instruction B 3!
- 2) Available with inspection certificate 3.1 acc. to EN 10 204
- 3) Can also be supplied with handwheel made of steel
- 4) Available with graphite up to 300°C
- 5) Available with graphite up to 550°C
- 6) Type 1 available with graphite up to 400°C
- 7) 1.4122 quenched and tempered