



Product Information

Radar

Level measurement in bulk solids

VEGAPULS 67, SR 68 and 68

VEGA

Contents

1 Measuring principle 3

2 Type overview 4

3 Instrument selection 5

4 Selection criteria 6

5 Housing overview. 7

6 Mounting 8

7 Electronics - 4 ... 20 mA/HART - two-wire 9

8 Electronics - 4 ... 20 mA/HART - four-wire 10

9 Electronics - Profibus PA 11

10 Electronics - Foundation Fieldbus 12

11 Electronics - Modbus 13

12 Operation 14

13 Dimensions 15

Take note of safety instructions for Ex applications



Please note the Ex specific safety information which you can find on our homepage www.vega.com under: "Downloads - Approvals" and which comes with every instrument. In hazardous areas you should take note of the corresponding regulations, conformity and type approval certificates of the sensors and power supply units. The sensors must only be operated on intrinsically safe circuits. The permissible electrical values are stated in the certificate.

1 Measuring principle

Measuring principle

Extremely short microwave pulses are emitted by the antenna system in the direction of the measured product, reflected by the product surface and received back again by the antenna system. They propagate at the speed of light. The time from emission to reception of the signals is proportional to the level in the vessel.

A special time stretching procedure allows reliable and precise measurement of the extremely short signal running times. The radar sensors operate with low transmission power in the C or K band frequency range. The proven ECHOFOX signal processing software selects the correct level echo out of a large number of interfering reflections. An adjustment with empty and full vessel is not necessary.

Application in bulk solids

High frequency sensors in K-band technology are used for these applications. Due to the very good signal focussing, internal silo installations or buildup on the vessel wall do not influence the measurement. A high sensitivity electronics adapted to the requirements of bulk solids measurement enables reliable level measurement of different products up to 75 m. The measuring principle is unaffected by strong dust generation, filling noise, air flow due to pneumatic filling and temperature fluctuations. The application areas extend from the food industry and plastics processing to steel production and minerals processing.

Input variable

The measured variable is the distance between the process fitting of the sensor and the product surface. The reference plane is the seal surface of the flange.

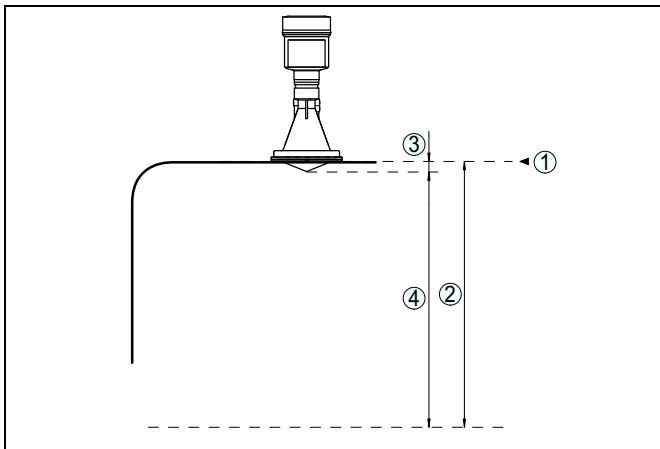

Fig. 1: Data of the input variable

- 1 Reference plane
- 2 Measured variable, max. measuring range
- 3 Antenna length
- 4 Useful measuring range

2 Type overview

VEGAPULS 67

VEGAPULS SR 68

VEGAPULS 68

Applications	Solids	Bulk solids under extremely difficult process conditions	Bulk solids under extremely difficult process conditions
Max. measuring range	15 m (49.21 ft)	30 m (98.43 ft)	75 m (246.1 ft)
Antenna/Material	Completely encapsulated plastic horn antenna/PVDF	Horn antenna/316L	Horn or parabolic antenna/316L
Process fitting/Material	Mounting strap/316L or flange/PP	Thread G1½A/316L according to DIN 3852-A or flange/316L	Thread G1½A/316L according to DIN 3852-A or flange/316L
Process temperature	-40 ... +80 °C (-40 ... +176 °F)	-40 ... +250 °C (-40 ... +482 °F)	-200 ... +450 °C (-328 ... +842 °F)
Process pressure	-1 ... +2 bar/-100 ... +200 kPa (-14.5 ... +29.0 psig)	-1 ... +100 bar/-100 ... +10000 kPa (-14.5 ... +1450 psi)	-1 ... +160 bar/-100 ... +16000 kPa (-14.5 ... +2320 psi)
Deviation	±2 mm	±2 mm	±2 mm
Frequency range	K-band	K-band	K-band
Signal output	<ul style="list-style-type: none"> • 4 ... 20 mA/HART two-wire • 4 ... 20 mA/HART four-wire • Profibus PA • Foundation Fieldbus • Modbus, Levelmaster protocol 	<ul style="list-style-type: none"> • 4 ... 20 mA/HART two-wire • 4 ... 20 mA/HART four-wire • Profibus PA • Foundation Fieldbus • Modbus, Levelmaster protocol 	<ul style="list-style-type: none"> • 4 ... 20 mA/HART two-wire • 4 ... 20 mA/HART four-wire • Profibus PA • Foundation Fieldbus • Modbus, Levelmaster protocol
Indication/Adjustment	<ul style="list-style-type: none"> • PLICSCOM • PACTware • VEGADIS 61 • VEGADIS 62 	<ul style="list-style-type: none"> • PLICSCOM • PACTware • VEGADIS 61 • VEGADIS 62 	<ul style="list-style-type: none"> • PLICSCOM • PACTware • VEGADIS 61 • VEGADIS 62
Approvals	<ul style="list-style-type: none"> • ATEX • IEC • FM • CSA 	<ul style="list-style-type: none"> • ATEX • IEC • Shipbuilding • FM • CSA 	<ul style="list-style-type: none"> • ATEX • IEC • Shipbuilding • FM • CSA

3 Instrument selection

Application ranges

VEGAPULS 67

VEGAPULS 67 is suitable for level measurement of bulk solids. The mechanical construction and the electronics are optimised for this application.

Application possibilities can be found in the food processing industry, in plastics processing and steel production as well as in the building industry.

VEGAPULS SR 68 and VEGAPULS 68

VEGAPULS SR 68 and VEGAPULS 68 are designed for level measurement of bulk solids even under the most difficult process conditions. The mechanical construction as well as the electronics are optimised for this application.

Application possibilities can be found in the food processing industry, in plastics processing and steel production as well as in the building industry.

Applications

Measurements with flange mounting

For mounting VEGAPULS 67 on a socket, an appropriate compression flange for DN 80 (ASME 3" or JIS 80) as well as a suitable adapter flange are available.

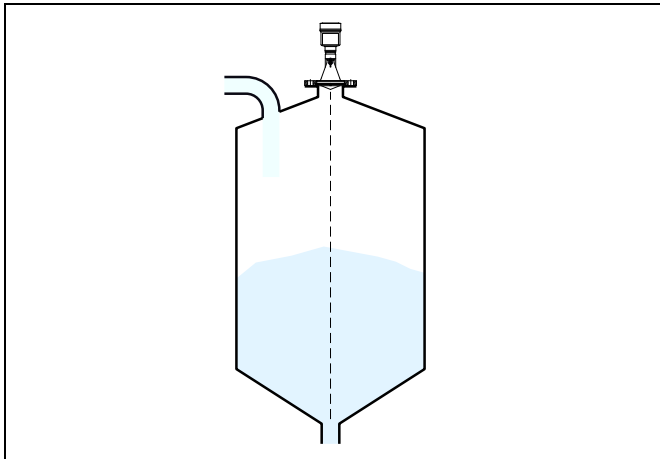

Fig. 2: Flange mounting of VEGAPULS 67

Measurement setups with mounting strap

The mounting strap enables simple mounting on the vessel wall or silo top. It is suitable for wall, ceiling or boom mounting. Especially in open vessels this is a very easy and effective way to align the sensor to the bulk solid surface.

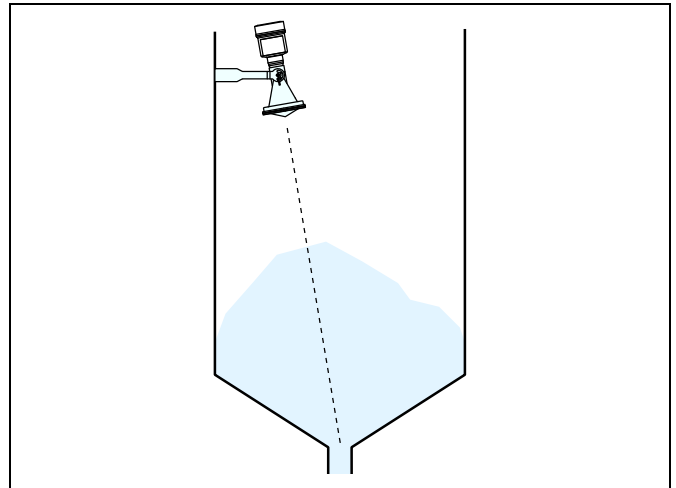

Fig. 3: VEGAPULS 67 with mounting strap

Measurements with swivelling holder

If mounting in the centre of the silo is not possible, the sensor can be directed to the vessel center by using the optional swivelling holder. The following illustration shows a simple way to determine the required angle of inclination.

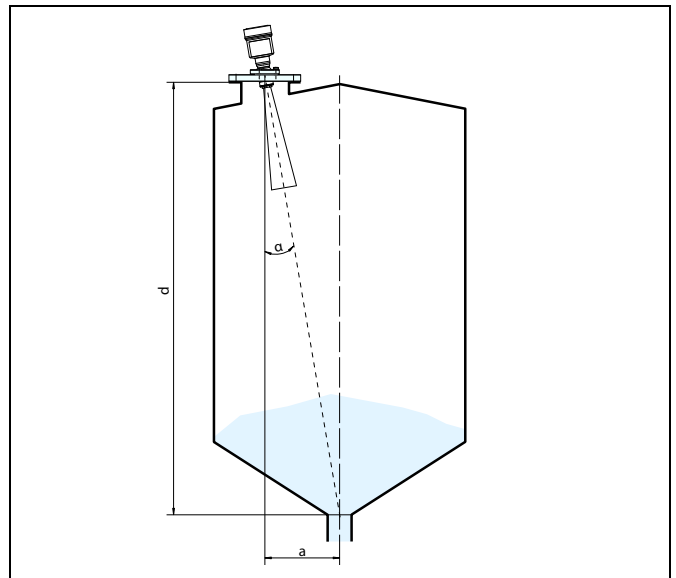





Fig. 4: VEGAPULS SR 68 or VEGAPULS 68 with swivelling holder



4 Selection criteria

		VEGAPULS 67	VEGAPULS SR 68	VEGAPULS 68
Vessel	Small to medium-size vessels	●	●	●
	Medium-size to large vessels	–	●	●
	Large vessel	–	–	●
Process	Easy process conditions	●	●	●
	Extremely difficult process conditions	–	●	●
Installation	Threaded fittings	–	●	●
	Flange connections	●	●	●
	Mounting strap	●	–	–
Antenna	Swivelling holder	●	●	●
	Parabolic antenna	–	–	●
	Rinsing air connection	–	●	●
Suitability for industry-specific applications	Aggregates and mining industry	●	●	●
	Chemical	●	●	●
	Power generation	–	●	●
	Foodstuffs	●	●	●
	Metal production	●	●	●
	Offshore	–	●	●
	Paper	●	●	●
	Petrochemical	–	●	●
	Pharmaceutical	–	●	●
	Environment and recycling industry	●	●	●
	Cement industry	●	●	●

5 Housing overview

Plastic PBT		
Protection rating	IP 66/IP 67	IP 66/IP 67
Version	Single chamber	Double chamber
Application area	Industrial environment	Industrial environment

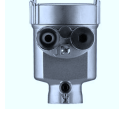
Aluminium		
Protection rating	IP 66/IP 67, IP 66/IP 68 (1 bar)	IP 66/IP 67, IP 66/IP 68 (1 bar)
Version	Single chamber	Double chamber
Application area	Industrial environment with increased mechanical wear	Industrial environment with increased mechanical wear

Stainless steel 316L			
Protection rating	IP 66/IP 67	IP 66/IP 67, IP 66/IP 68 (1 bar)	IP 66/IP 67, IP 66/IP 68 (1 bar)
Version	Single chamber electropolished	Single chamber precision casting	Double chamber precision casting
Application area	Aggressive environment, food processing, pharmaceutical	Aggressive environment, strong mechanical wear	Aggressive environment, strong mechanical wear

6 Mounting

Mounting examples

The following illustrations show mounting examples and measurement setups.

Plastic granules

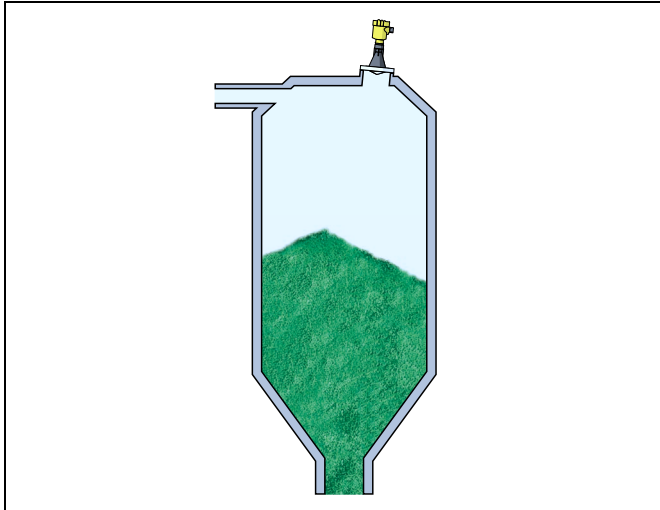

Fig. 5: Level measurement in a plastic granules silo with VEGAPULS 67

Plastic granules and powder are often stored in high, narrow silos which are filled pneumatically. Typical conditions are filling noise, material cones and poor reflective properties.

The high sensitivity of the VEGAPULS 67 sensor guarantees ample performance reserves for reliable level measurement even with widely varying product surface geometries.

Fine lime

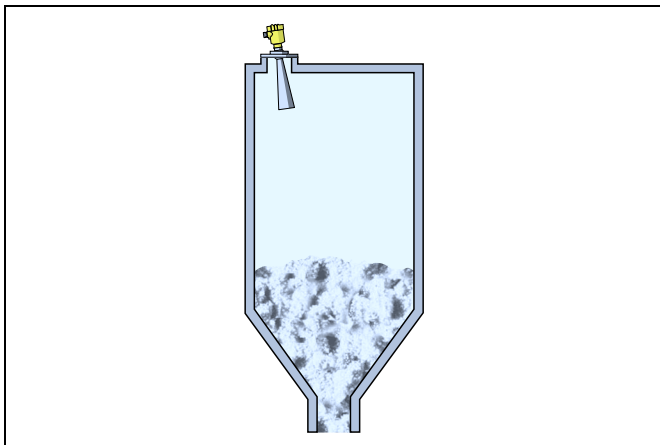

Fig. 6: Level measurement in a lime silo with VEGAPULS SR 68

Due to the extreme dust generation during the filling of powders, a non-contact measurement with ultrasonics is virtually impossible. The VEGAPULS SR 68 is the ideal solution since microwaves are unaffected by dust generation and the filling stream.

The VEGAPULS SR 68 radar sensor is the ideal measuring instrument for this application. With a swivelling holder it can be optimally aligned to the product surface.

Clinker silo

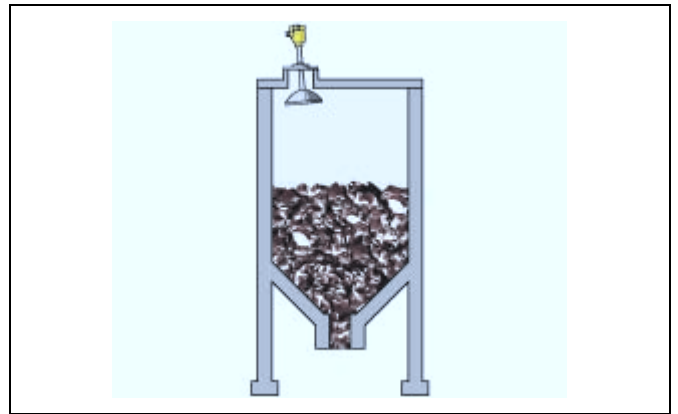

Fig. 7: Level measurement in a clinker silo with VEGAPULS 68

Clinker is an additive for concrete and is stored in large silos or bunkers. Its abrasive properties as well as extreme dust generation during filling place heavy demands on the level measurement.

The VEGAPULS 68 sensor is the optimum solution for level measurement. Its parabolic antenna powerfully focuses the microwaves, thus generating a strong useful signal. Interference from struts or installations is excluded.

7 Electronics - 4 ... 20 mA/HART - two-wire

Configuration of the electronics

The pluggable electronics is mounted in the electronics compartment of the instrument and can be exchanged by the user when servicing is required. The electronics is completely encapsulated to protect against vibration and moisture.

The terminals for voltage supply as well as contact pins with I²C interface for parameter adjustment are located on the upper side of the electronics. With the double chamber housing, the terminals are located in the separate connection compartment.

Voltage supply

Depending on the version, the supply voltage and the current signal are carried on the same two-wire connection cable.

The VEGA power supply units VEGATRENN 149AEx, VEGASTAB 690, VEGADIS 371 as well as VEGAMET signal conditioning instruments are suitable for power supply. When one of these instruments is used, a reliable separation of the supply circuits from the mains circuits according to DIN VDE 0106 part 101 is realised for the sensor.

- Operating voltage
 - 9.6 ... 36 V DC
- Permissible residual ripple - Non-Ex, Ex-ia instrument
 - for $9.6 \text{ V} < U_N < 14 \text{ V}$: $\leq 0.7 \text{ V}_{\text{eff}}$ (16 ... 400 Hz)
 - for $18 \text{ V} < U_N < 36 \text{ V}$: $\leq 1.0 \text{ V}_{\text{eff}}$ (16 ... 400 Hz)

Connection cable

The sensors are connected with standard cable without screen. An outer cable diameter of 5 ... 9 mm ensures the seal effect of the cable entry.

If electromagnetic interference is expected which is above the test values of EN 61326 for industrial areas, screened cable should be used. In HART multidrop mode the use of screened cable is generally recommended.

Cable screening and grounding

If screened cable is necessary, the cable screen must be connected on both ends to ground potential. If potential equalisation currents are expected, the connection on the evaluation side must be made via a ceramic capacitor (e.g. 1 nF, 1500 V).

Connection single chamber housing

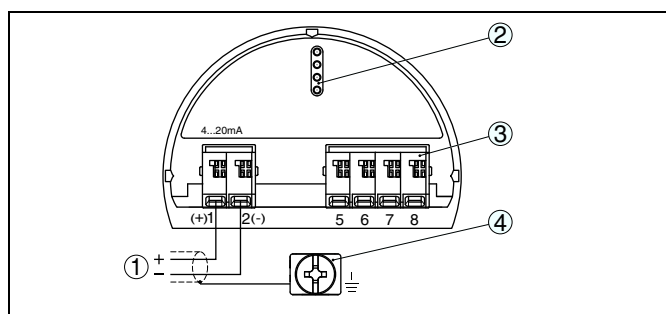

Fig. 8: Electronics and connection compartment, single chamber housing

- 1 Voltage supply/Signal output
- 2 For indicating and adjustment module or interface adapter
- 3 For external indicating and adjustment unit
- 4 Ground terminal for connection of the cable screen

Connection double chamber housing

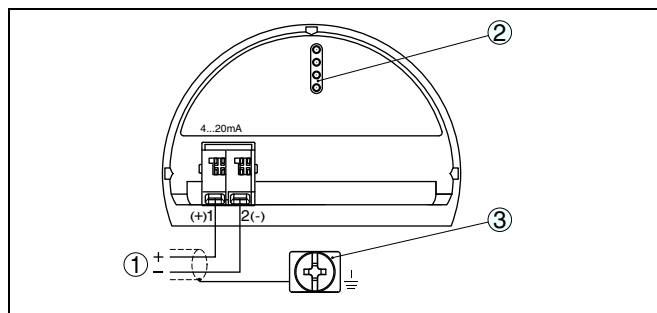

Fig. 9: Connection compartment double chamber housing

- 1 Voltage supply/Signal output
- 2 For indicating and adjustment module or interface adapter
- 3 Ground terminal for connection of the cable screen

8 Electronics - 4 ... 20 mA/HART - four-wire

Configuration of the electronics

The pluggable electronics is mounted in the electronics compartment of the instrument and can be exchanged by the user when servicing is required. The electronics is completely encapsulated to protect against vibration and moisture.

The contact pins with I²C interface for parameter adjustment are located on the upper side of the electronics. The terminals for the power supply are located in the separate connection compartment.

Voltage supply

If a reliable separation is required, the power supply and the current output are transmitted over separate two-wire connection cables.

- Operating voltage with version for low voltage
 - 9.6 ... 48 V DC, 20 ... 42 V AC, 50/60 Hz
- Operating voltage with version for mains voltage
 - 90 ... 253 V AC, 50/60 Hz

Connection cable

The 4 ... 20 mA current output is connected with standard two-wire cable without screen. If electromagnetic interference is expected which is above the test values of EN 61326 for industrial areas, screened cable should be used.

For power supply, an approved installation cable with PE conductor is required.

An outer cable diameter of 5 ... 9 mm ensures the seal effect of the respective cable entry.

Cable screening and grounding

If screened cable is necessary, the cable screen must be connected on both ends to ground potential. If potential equalisation currents are expected, the connection on the evaluation side must be made via a ceramic capacitor (e.g. 1 nF, 1500 V).

Connection double chamber housing

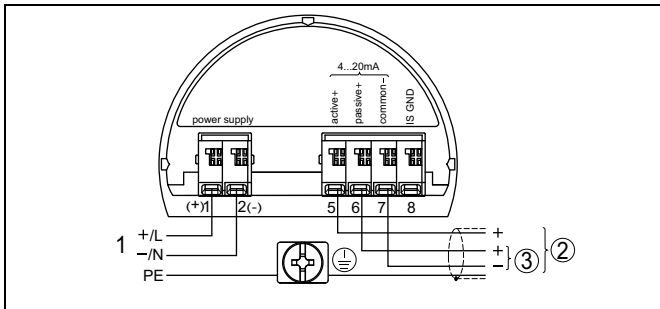

Fig. 10: Connection compartment double chamber housing

- 1 Voltage supply
- 2 4 ... 20 mA signal output active
- 3 4 ... 20 mA signal output passive

9 Electronics - Profibus PA

Configuration of the electronics

The pluggable electronics is mounted in the electronics compartment of the instrument and can be exchanged by the user when servicing is required. The electronics is completely encapsulated to protect against vibration and moisture.

The terminals for voltage supply as well as the plug with I²C interface for parameter adjustment are located on the upper side of the electronics. With the double chamber housing, these connection elements are located in the separate connection compartment.

Voltage supply

Power supply via the H1 Fieldbus cable.

- Operating voltage
 - 9 ... 32 V DC
- Max. number of sensors with DP/PA segment coupler
 - 32
- Max. number of sensors with VEGALOG 571 EP input card
 - 10

Connection cable

Connection is made with screened cable according to Profibus specification. A cable diameter of 5 ... 9 mm ensures the seal effect of the cable gland.

Make sure that the entire installation is carried out according to the Profibus specification. In particular, make sure that the bus is terminated with suitable terminating resistors.

Cable screening and grounding

With systems with potential equalisation, connect the cable screen directly to ground potential at the power supply unit, in the connection box and at the sensor. The screen in the sensor must be connected directly to the internal ground terminal. The ground terminal outside on the housing must be connected to the potential equalisation (low impedance).

In systems without potential equalisation, connect the cable screen directly to ground potential at the power supply unit and at the sensor. In the connection box or T-distributor, the screen of the short stub to the sensor must not be connected to ground potential or to another cable screen. The cable screens to the power supply unit and to the next distributor must be connected to each other and also connected to ground potential via a ceramic capacitor (e.g. 1 nF, 1500 V). Low-frequency potential equalisation currents are thus suppressed, but the protective effect against high frequency interference signals remains.

Connection single chamber housing

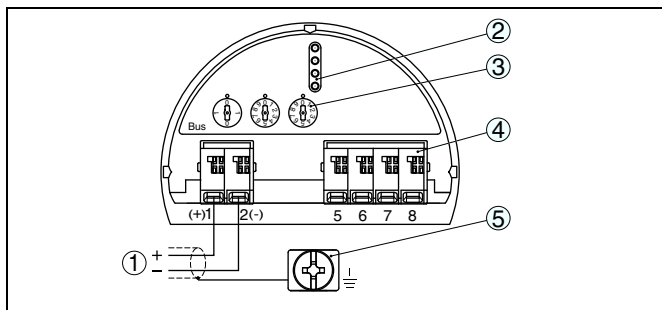

Fig. 11: Electronics and connection compartment, single chamber housing

- 1 Voltage supply/Signal output
- 2 For indicating and adjustment module or interface adapter
- 3 Selection switch for bus address
- 4 For external indicating and adjustment unit
- 5 Ground terminal for connection of the cable screen

Connection double chamber housing

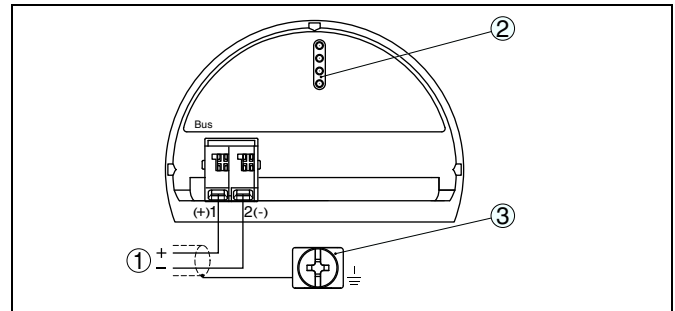

Fig. 12: Connection compartment double chamber housing

- 1 Voltage supply/Signal output
- 2 For indicating and adjustment module or interface adapter
- 3 Ground terminal for connection of the cable screen

10 Electronics - Foundation Fieldbus

Configuration of the electronics

The pluggable electronics is mounted in the electronics compartment of the instrument and can be exchanged by the user when servicing is required. The electronics is completely encapsulated to protect against vibration and moisture.

The terminals for voltage supply as well as the plug with I²C interface for parameter adjustment are located on the upper side of the electronics. With the double chamber housing, these connection elements are located in the separate connection compartment.

Voltage supply

Power supply via the H1 Fieldbus cable.

- Operating voltage
 - 9 ... 32 V DC
- max. number of sensors
 - 32

Connection cable

Connection is made with screened cable according to Fieldbus specification. A cable diameter of 5 ... 9 mm ensures the seal effect of the cable gland.

Make sure that the entire installation is carried out according to the Fieldbus specification. In particular, make sure that the bus is terminated with suitable terminating resistors.

Cable screening and grounding

With systems with potential equalisation, connect the cable screen directly to ground potential at the power supply unit, in the connection box and at the sensor. The screen in the sensor must be connected directly to the internal ground terminal. The ground terminal outside on the housing must be connected to the potential equalisation (low impedance).

In systems without potential equalisation, connect the cable screen directly to ground potential at the power supply unit and at the sensor. In the connection box or T-distributor, the screen of the short stub to the sensor must not be connected to ground potential or to another cable screen. The cable screens to the power supply unit and to the next distributor must be connected to each other and also connected to ground potential via a ceramic capacitor (e.g. 1 nF, 1500 V). Low-frequency potential equalisation currents are thus suppressed, but the protective effect against high frequency interference signals remains.

Connection single chamber housing

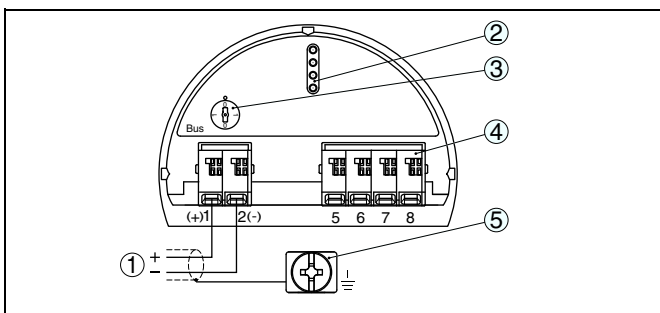

Fig. 13: Electronics and connection compartment, single chamber housing

- 1 Voltage supply/Signal output
- 2 Contact pins for the indicating and adjustment module or interface adapter
- 3 Selection switch for bus address
- 4 For external indicating and adjustment unit
- 5 Ground terminal for connection of the cable screen

Connection double chamber housing

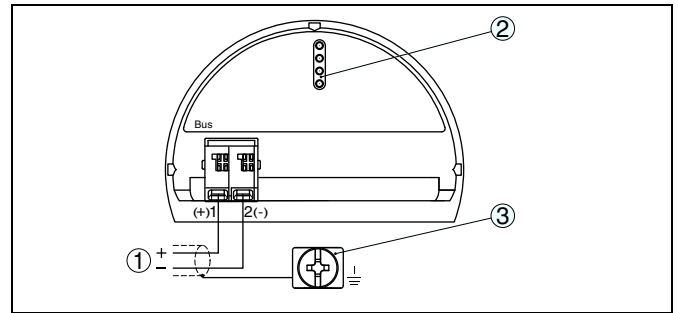

Fig. 14: Connection compartment double chamber housing

- 1 Voltage supply/Signal output
- 2 For indicating and adjustment module or interface adapter
- 3 Ground terminal for connection of the cable screen

11 Electronics - Modbus

Configuration of the electronics

The pluggable electronics is mounted in the electronics compartment of the instrument and can be exchanged by the user when servicing is required. The electronics is completely encapsulated to protect against vibration and moisture.

The contact pins with I²C interface for parameter adjustment are located on the upper side of the electronics. The terminals for the power supply are located in the separate connection compartment.

Voltage supply

Power supply via the Modbus host.

- Operating voltage
 - 8 ... 30 V DC
- max. number of sensors
 - 15

Connection cable

Connection is carried out with screened cable according to Fieldbus specification.

For power supply, a separate two-wire cable is required.

Make sure that the entire installation is carried out according to the Fieldbus specification. In particular, make sure that the bus is terminated with suitable terminating resistors.

An outer cable diameter of 5 ... 9 mm ensures the seal effect of the respective cable entry.

Cable screening and grounding

With systems with potential equalisation, connect the cable screen directly to ground potential at the power supply unit, in the connection box and at the sensor. The screen in the sensor must be connected directly to the internal ground terminal. The ground terminal outside on the housing must be connected to the potential equalisation (low impedance).

In systems without potential equalisation, connect the cable screen directly to ground potential at the power supply unit and at the sensor. In the connection box or T-distributor, the screen of the short stub to the sensor must not be connected to ground potential or to another cable screen. The cable screens to the power supply unit and to the next distributor must be connected to each other and also connected to ground potential via a ceramic capacitor (e.g. 1 nF, 1500 V). Low-frequency potential equalisation currents are thus suppressed, but the protective effect against high frequency interference signals remains.

Connection compartment

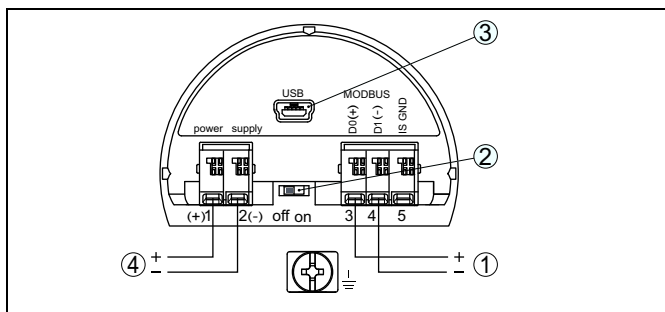

Fig. 15: Connection compartment

- 1 Modbus connection
- 2 Slide switch for integrated termination resistor (120 Ω)
- 3 USB connection
- 4 Voltage supply

29427-EN-120405

12 Operation

12.1 Overview

The sensors can be adjusted with the following adjustment media:

- With indicating and adjustment module
- With external indicating and adjustment unit
- an adjustment software according to FDT/DTM standard, e.g. PACTware and PC

as well as via systems from other manufacturers, dependent on the signal output:

- A HART handheld (4 ... 20 mA/HART)
- The adjustment program AMS (4 ... 20 mA/HART and Foundation Fieldbus)
- The adjustment program PDM (Profibus PA)
- A configuration tool (Foundation Fieldbus)

The entered parameters are generally saved in the sensor, optionally also in the indicating and adjustment module or in the adjustment program.

12.2 Indicating and adjustment module PLICSCOM

The pluggable indicating and adjustment module is used for measured value indication, operation and diagnosis. It is equipped with an illuminated full dot matrix as well as four keys for adjustment.



Fig. 16: Indicating and adjustment module PLICSCOM

The indicating and adjustment module is integrated in the respective sensor housing or in the external indicating and adjustment unit. After mounting, the sensor as well as the indicating and adjustment module are splash-proof even without housing cover.

12.3 External indicating and adjustment unit VEGADIS 62

VEGADIS 62 is suitable for measured value indication and adjustment of sensors with HART protocol. The instrument is looped into the 4 ... 20 mA/HART signal cable.



Fig. 17: External indicating and adjustment unit VEGADIS 62

12.4 PACTware/DTM

As an alternative to the indicating and adjustment module, the sensor can also be configured via a Windows PC. To do this, the configuration software PACTware and a suitable instrument driver (DTM) according to the FDT standard are required. The current PACTware version as well as all available DTMs are compiled in a DTM Collection. The DTMs can also be integrated into other frame applications according to the FDT standard.

All device DTMs are available as a free-of-charge standard version and as a full version that must be purchased. In the standard version, all functions for complete setup are already included. An assistant for simple project configuration simplifies the adjustment considerably. Saving/printing the project as well as import/export functions are also part of the standard version.

In the full version there is also an extended print function for complete project documentation as well as a save function for measured value and echo curves. In addition, there is a tank calculation program as well as a multiviewer for display and analysis of the saved measured value and echo curves.

Connection of the PC via VEGACONNECT

The interface converter VEGACONNECT is required for connection of the PC. On the computer side, the connection is made via USB interface. The VEGACONNECT is placed instead of the indicating and adjustment module to the sensor, the connection to the sensor is made automatically. As an alternative the connection via the HART signal can be carried out on any position of the signal cable with 4 ... 20 mA/HART sensors.

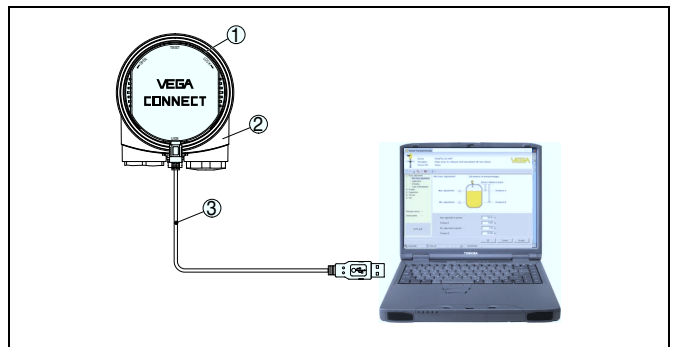

Fig. 18: Connection via VEGACONNECT and USB

- 1 VEGACONNECT
- 2 plics® sensor
- 3 USB cable to the PC

Necessary components:

- VEGAPULS
- PC with PACTware and suitable DTM
- VEGACONNECT
- Voltage supply/Processing system

12.5 Alternative adjustment programs

PDM

For HART and Profibus PA sensors, device descriptions are available as EDDs for the adjustment program PDM. The device descriptions are already included in the current version of the PDM. Newer instrument drivers that are not yet delivered with the PDM are available in the download section.

AMS

For HART and Foundation Fieldbus sensors, device descriptions are available as EDDs for the adjustment program AMS. The device descriptions are already included in the current version of the AMS. Newer instrument drivers that are not yet delivered with the AMS are available in the download section.

13 Dimensions

Plastic housing

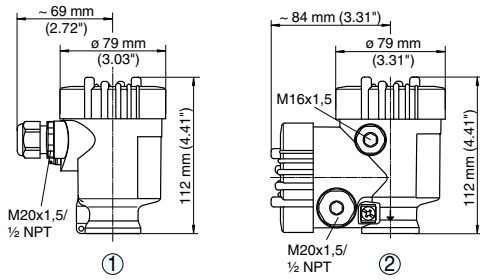

- 1 Single chamber housing
- 2 Double chamber housing

Aluminium housing

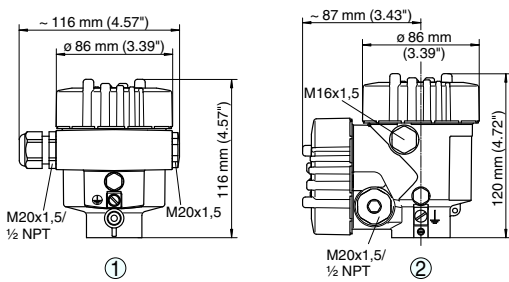

- 1 Single chamber housing
- 2 Double chamber housing

Stainless steel housing

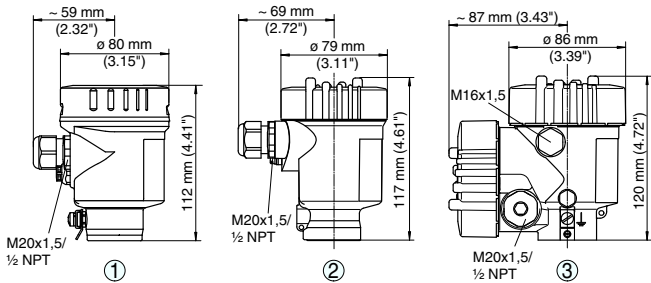

- 1 Single chamber housing electropolished
- 2 Single chamber housing precision casting
- 3 Double chamber housing precision casting

VEGAPULS 67

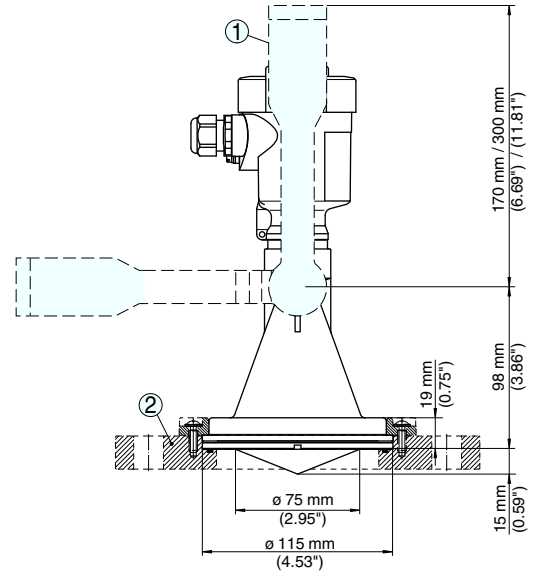

- 1 Mounting strap
- 2 Adapter flange

VEGAPULS SR 68

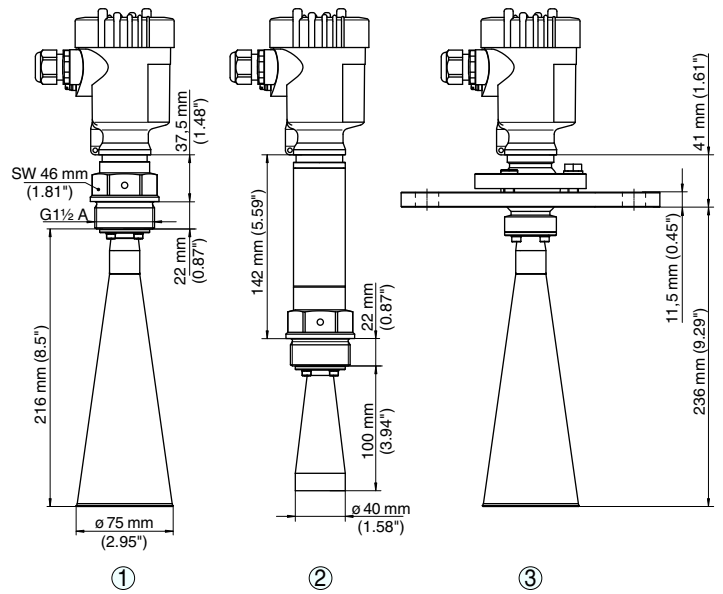

- 1 Threaded version
- 2 Threaded version with temperature adapter
- 3 Flange version with swivelling holder

VEGAPULS 68

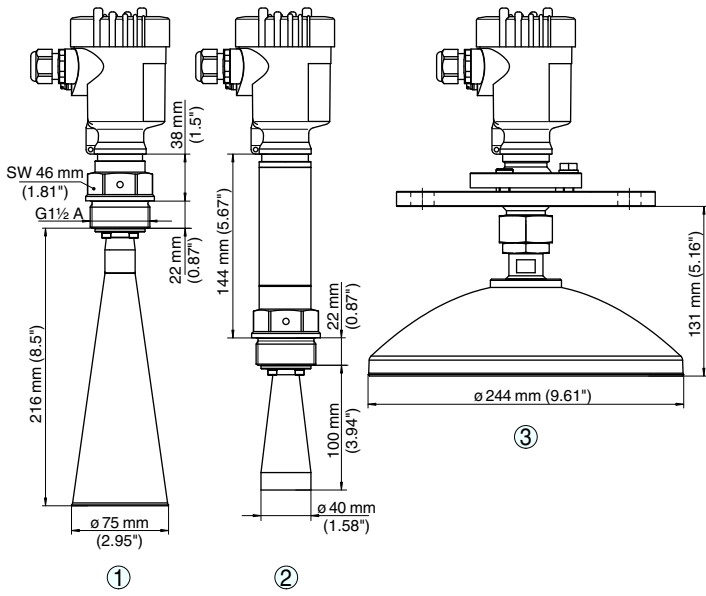

- 1 Threaded version with horn antenna
- 2 Threaded version with horn antenna and temperature adapter
- 3 Version with parabolic antenna

The listed drawings are only an excerpt of the available process fittings. You can find further drawings on our homepage www.vega.com » Downloads » Drawings.



VEGA

VEGA Grieshaber KG
Am Hohenstein 113
77761 Schiltach
Germany
Phone +49 7836 50-0
Fax +49 7836 50-201
E-Mail: info.de@vega.com
www.vega.com

You can find at www.vega.com

- operating instructions manuals
- specification sheet
- Software
- drawings
- certificates
- approvals

and much, much more



Subject to change without prior notice

29427-EN-120405