

# MWIR- BORESCOPE-640

THERMAL IMAGING SOLUTIONS

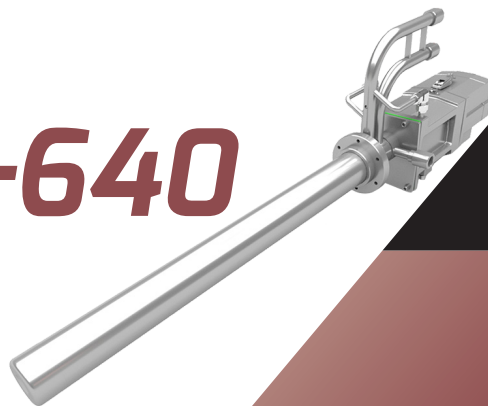

① 300-1800 °C / 572-3272 °F



**LAND**  
**AMETEK®**



QUALITY CUSTOMER SOLUTIONS

# MWIR-BORESCOPE-640

THERMAL IMAGING SOLUTIONS

## AMETEK LAND HAS BEEN MANUFACTURING PRECISION MEASURING EQUIPMENT SINCE 1947.

We are specialists in non-contact temperature measurement and combustion monitoring with applications across diverse industries such as steel and glass making, power generation and cement manufacture.

As part of AMETEK Process & Analytical Instruments Division since 2006, our customers benefit from our worldwide AMETEK sales and service team.

**Building on more than twenty years of thermal imaging experience, AMETEK Land continues to expand its range of temperature measurement solutions with the addition of the MWIR-BoreScope-640.**

Combustion atmospheres using dirty fuels require a thermal imaging solution with advanced spectral filtering and high resolution to deliver clear live images from within a furnace, boiler or incinerator.

The MWIR-B-640 provides a continuous and clear view, even through heavy smoke and hot furnace atmospheres, which is not possible when using visual and Near-IR camera systems.

The MWIR-B-640 allows highly accurate and fully radiometric temperature measurement image data to be taken, stored, and trended over the lifetime of the furnace or boiler.

The advanced IMAGEPro thermal imaging and data processing software supports long term data trending and enables the early detection of leaks and temperature variations to help optimise processes. Operators have a clear view of the critical areas within

the furnace or boiler with more than 300,000 accurate point temperatures, measuring in the range of 300-1200 °C (572-2192 °F) or 500-1800 °C (932-3272 °F). Providing advanced digital communications via the IMAGEPro software, the performance of the furnace or boiler can be monitored to easily identify hot and cold areas and any uneven heating can be viewed in real-time from the safety of the control room.

The high-resolution image, combined with the wide-angle field of view (90°), allows multiple areas to be imaged and measured simultaneously.

The MWIR-B-640 uses proven thermal imaging technology to accurately and continuously profile the temperatures within the furnace or boiler providing improved data accuracy through automation and minimising risk to personnel by reducing the need for personnel to be in the hazardous area around the furnace or boiler.

The MWIR-B-640 is an invaluable tool in optimising production throughput, reducing energy consumption, and extending boiler or furnace campaign life.

### FIELD VIEW OF OPTICS ▼

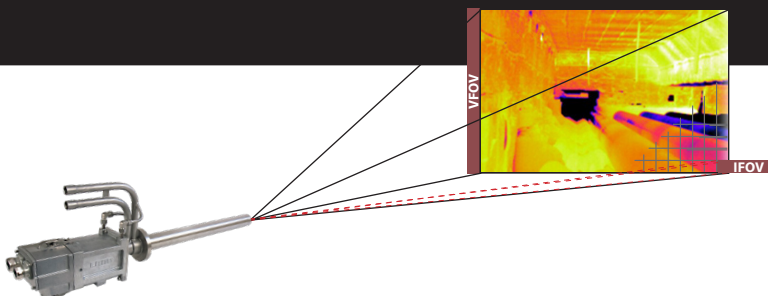

Distance	1 m			5 m			10 m			15 m			20 m		
	Width	Height	IFOV (centre)	Width	Height	IFOV (centre)	Width	Height	IFOV (centre)	Width	Height	IFOV (centre)	Width	Height	IFOV (centre)
<b>90° x 67.5°</b>	2.0 m	1.3 m	2.5 mm	10.0 m	6.7 m	12.3 mm	20.0 m	13.4 m	24.5 mm	30.0 m	20.1 m	36.8 mm	40.0 m	26.7 m	49.1 mm

# SPECIFICATION & DESIGN

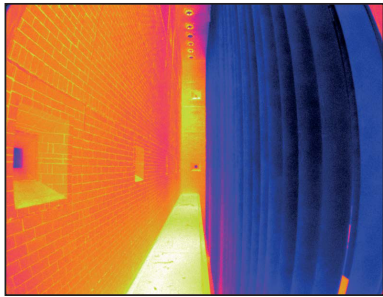

Tube furnace showing a wide range of accurate, low and high-temperature readings.

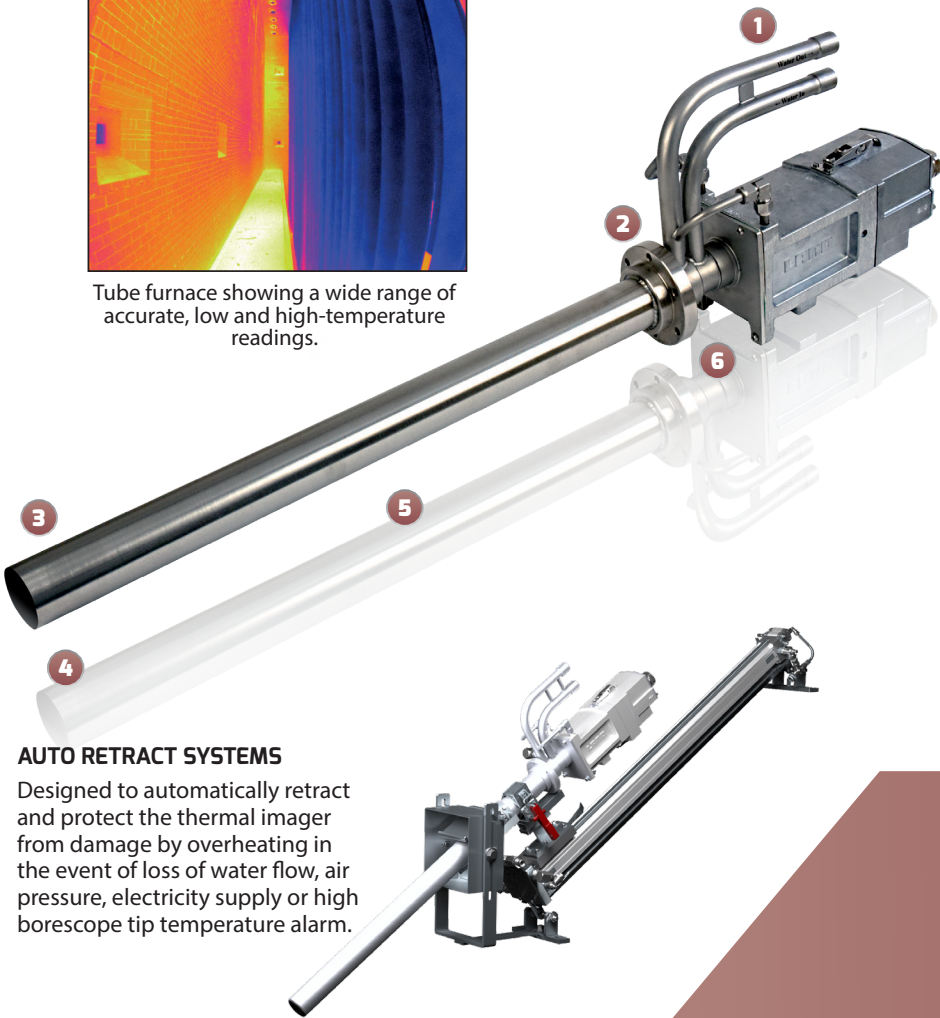

## 1: HIGH-PERFORMANCE WATER COOLING SYSTEM

Low water flow requirements, even in the highest temperature furnaces, results in low running costs

## 2: RANGE OF MOUNTING OPTIONS

Standard mounting options are available to ensure simple installation

## 3: THERMOCOUPLE AT MWIR-B-640 TIP

Giving the operator an alarm for removing the instrument, preventing damage if maximum temperatures are exceeded

## 4: VIEWING ANGLE

90° angle provides a thermal view of multiple areas. 640 x 480 resolution gives 307,200 data points

## 5: PROBE LENGTHS

Range of probe lengths suitable for every installation

## 6: INTEGRATED AIR PURGE

The air purge maintains a dust-free optical system while consuming minimal instrument air

## AUTO RETRACT SYSTEMS

Designed to automatically retract and protect the thermal imager from damage by overheating in the event of loss of water flow, air pressure, electricity supply or high borescope tip temperature alarm.

## TYPICAL APPLICATIONS

Coal-fired Boilers	Cement Kilns
Biomass Boilers	Waste Heat Boilers
Incinerators	Reheat Furnaces
Steam Methane Reformers	Annealing Furnaces
Heat Treatment Furnaces	Ethylene Cracking Furnaces

## SYSTEM BENEFITS

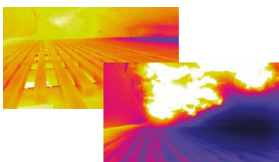

**ADVANCED SPECTRAL FILTERING** enables an extensive and clear view even through dusty and smoky furnace atmospheres.



**24/7 OPERATION AND REMOTE PROCESS MONITORING** reduces the risk to personnel by removing the need for an operator to be in the area regularly.

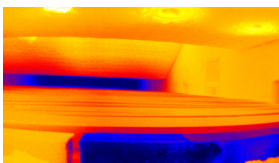

**FULLY-RADIOMETRIC AND HIGHLY ACCURATE** temperature measurement at > 300,000 pixels.

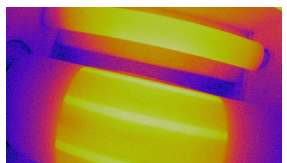

**PATENTED BACKGROUND REFLECTION COMPENSATION** can correct for the effect of background reflection in real-time enabling accurate target temperature readings.

## FEATURES & BENEFITS

**ADVANCED SPECTRAL FILTERING** - enabling a clear view through dusty/smoky and hot furnace atmospheres, working in the midwave Infrared range

**HIGH-TEMPERATURE MEASUREMENT ACCURACY** - enables optimum furnace and boiler control through enhanced process thermal imaging

**ADVANCED IMAGE PROCESSING SOFTWARE** - control, monitor, analyse and capture data from the thermal imaging camera with IMAGEPro

**LIVE THERMAL DATA COMBINED WITH HIGH-RESOLUTION, LOW NOISE VISUAL IMAGE** - allow real-time furnace optimisation and the opportunity to improve energy efficiency without degrading furnace/boiler lifetime

**SAFE 24 HOUR, 7 DAY MONITORING** - guarantees accurate, reliable data from a safe remote position without risk to the operators

# MWIR-BOREScope-640

THERMAL IMAGING SOLUTIONS

## SPECIFICATIONS

### CAMERA UNIT & HOUSING

Measurement Range:	300-1200 °C / 572-2192 °F 500-1800 °C / 932-3272 °F
Pixel Resolution:	640x480
Spectral Response:	3.9 µm
Frame Rate:	60 fps* / 7.5 fps
Detector:	FPA - Microbolometer
Optic (HFOV x VFOV):	90° x 67.5°
Optic (IFOV):	2.4 mrad
Focus Range:	1 m to infinity
Probe Diameter:	Ø 61 mm / Ø 2.4"
Probe Lengths:	305, 609 or 914 mm (12", 24" or 36")
Mountings:	Choice of 3" ANSI 150 RF Flange & Gasket or PN16 DN80 Flange & Gasket with a 12" standpipe
Protection Window:	Sapphire
Accuracy:	1% of reading or 5 °C (300-1200 °C range) 1% of reading (500-1800 °C range)
Repeatability:	1 °C below 50 °C ambient
Dimensions:	314 x 460 x 765 mm (or 1070 mm or 1374 mm) 12" x 18" x 30" (or 42" or 54")
Power Rating:	24 V DC
Weight:	< 25 kg (for 609 mm / 24" version)
Ambient Temperature:	-20 to 60 °C / -4 to 140 °F (0 - 95 % humidity, non-condensing)
Cooling/Purging Options:	Water cooling / Air purging
Environmental Rating:	IP65

### CAMERA SUPPLY

Connections:	Digital data over 1 GBit Ethernet (M12, 8 pin) Power (8 pin)
Alarm Functions:	Tip temperature warning, tip temperature alarm
Signal-LED:	Power, Ethernet, Tip-Temperature (green/yellow/red)
Service:	Water, instrument air and power input

### THERMAL IMAGER POWER SUPPLY

Components & Connections:	110/230V AC Wired ethernet connection (standard) / Fibre-optic data connection (option)
IP Rating:	IP65 / NEMA 4
Size:	380 x 380 x 211 mm / 15" x 15" x 8.3"
Weight:	15 kg (33.07 lbs)

### IMAGE PROCESSING

Software:	IMAGEPro Advanced Image Processing and Controlling Software
Workstation:	PC-Workstation (option)
Interfacing:	Open Data Interface, Modbus TCP, Moxa I/O unit

### STANDARD ACCESSORIES

Accessories (optional):	Power supply, cables, water-cooled/purged mounting and tube, software, workstation, auto-retraction system
-------------------------	--

\*60Hz instruments are subject to different export restrictions in different authorities and countries around the world. All sales must be subject to export licence review.

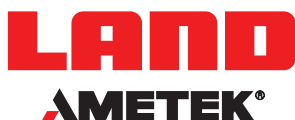

### CONTACT US



[www.ametek-land.com](http://www.ametek-land.com)



[land.enquiry@ametek.com](mailto:land.enquiry@ametek.com)



We are fully committed to Quality Assurance. See all our accreditations at [AMETEK-LAND.COM/QUALITY](http://AMETEK-LAND.COM/QUALITY)