

Operating Instructions

Pressure transmitter with metallic
measuring cell

VEGABAR 83

4 ... 20 mA/HART



Document ID: 45034



VEGA

Contents

1	About this document	
1.1	Function	4
1.2	Target group	4
1.3	Symbolism used	4
2	For your safety	
2.1	Authorised personnel	5
2.2	Appropriate use	5
2.3	Warning about incorrect use	5
2.4	General safety instructions	5
2.5	CE conformity	5
2.6	Measuring range - permissible process pressure	6
2.7	NAMUR recommendations	6
2.8	Environmental instructions	6
3	Product description	
3.1	Configuration	7
3.2	Principle of operation	8
3.3	Packaging, transport and storage	10
3.4	Accessories and replacement parts	11
4	Mounting	
4.1	General instructions to use the instrument	13
4.2	Ventilation and pressure compensation	14
4.3	Process pressure measurement	17
4.4	Level measurement	19
4.5	External housing	20
5	Connecting to power supply	
5.1	Preparing the connection	21
5.2	Connecting	22
5.3	Single chamber housing	23
5.4	Double chamber housing	24
5.5	Double chamber housing Ex d	26
5.6	Double chamber housing Ex d ia	26
5.7	Double chamber housing with DIS-ADAPT	27
5.8	Housing IP 66/IP 68 (1 bar)	28
5.9	External housing with version IP 68 (25 bar)	28
5.10	Switch-on phase	30
6	Set up with the display and adjustment module	
6.1	Insert display and adjustment module	31
6.2	Adjustment system	32
6.3	Parameter adjustment - Quick setup	33
6.4	Parameter adjustment - Extended adjustment	34
6.5	Saving the parameter adjustment data	48
7	Setup with PACTware	
7.1	Connect the PC	49
7.2	Parameter adjustment	50
7.3	Saving the parameter adjustment data	51

8	Set up with other systems	
8.1	DD adjustment programs	52
8.2	Field Communicator 375, 475	52
9	Diagnosis, asset management and service	
9.1	Maintenance	53
9.2	Diagnosis memory	53
9.3	Asset Management function.....	53
9.4	Rectify faults.....	57
9.5	Calculation of total deviation (according to DIN 16086).....	58
9.6	Exchange process assembly with version IP 68 (25 bar).....	59
9.7	Exchanging the electronics module.....	60
9.8	Software update	61
9.9	How to proceed in case of repair	61
10	Dismounting	
10.1	Dismounting steps.....	62
10.2	Disposal	62
11	Supplement	
11.1	Technical data	63
11.2	Dimensions	75



Safety instructions for Ex areas

Please note the Ex-specific safety information for installation and operation in Ex areas. These safety instructions are part of the operating instructions manual and come with the Ex-approved instruments.

Editing status: 2013-09-25

1 About this document

1.1 Function

This operating instructions manual provides all the information you need for mounting, connection and setup as well as important instructions for maintenance and fault rectification. Please read this information before putting the instrument into operation and keep this manual accessible in the immediate vicinity of the device.

1.2 Target group

This operating instructions manual is directed to trained specialist personnel. The contents of this manual should be made available to these personnel and put into practice by them.

1.3 Symbolism used



Information, tip, note

This symbol indicates helpful additional information.



Caution: If this warning is ignored, faults or malfunctions can result.

Warning: If this warning is ignored, injury to persons and/or serious damage to the instrument can result.

Danger: If this warning is ignored, serious injury to persons and/or destruction of the instrument can result.



Ex applications

This symbol indicates special instructions for Ex applications.



List

The dot set in front indicates a list with no implied sequence.



Action

This arrow indicates a single action.



Sequence of actions

Numbers set in front indicate successive steps in a procedure.



Battery disposal

This symbol indicates special information about the disposal of batteries and accumulators.

2 For your safety

2.1 Authorised personnel

All operations described in this operating instructions manual must be carried out only by trained specialist personnel authorised by the plant operator.

During work on and with the device the required personal protective equipment must always be worn.

2.2 Appropriate use

The VEGABAR 83 is a pressure transmitter for process pressure and hydrostatic level measurement.

You can find detailed information on the application range in chapter "*Product description*".

Operational reliability is ensured only if the instrument is properly used according to the specifications in the operating instructions manual as well as possible supplementary instructions.

2.3 Warning about incorrect use

Inappropriate or incorrect use of the instrument can give rise to application-specific hazards, e.g. vessel overflow or damage to system components through incorrect mounting or adjustment.

2.4 General safety instructions

This is a high-tech instrument requiring the strict observance of standard regulations and guidelines. The user must take note of the safety instructions in this operating instructions manual, the country-specific installation standards as well as all prevailing safety regulations and accident prevention rules.

The instrument must only be operated in a technically flawless and reliable condition. The operator is responsible for trouble-free operation of the instrument.

During the entire duration of use, the user is obliged to determine the compliance of the necessary occupational safety measures with the current valid rules and regulations and also take note of new regulations.

2.5 CE conformity

The device fulfills the legal requirements of the applicable EC guidelines. By affixing the CE marking, we confirm successful testing of the product.

You can find the CE Certificate of Conformity in the download section of our homepage.

Electromagnetic compatibility

Instruments with plastic housing as well as in four-wire or Ex-d-ia version are designed for use in an industrial environment. Nevertheless, electromagnetic interference from electrical conductors and

radiated emissions must be taken into account, as is usual with a class A instrument according to EN 61326-1. If the instrument is used in a different environment, the electromagnetic compatibility to other instruments must be ensured by suitable measures.

2.6 Measuring range - permissible process pressure

The permissible process pressure is specified on the type label with "process pressure", see chapter "*Configuration*". For safety reasons, this range must not be exceeded. This applies also if a measuring cell with higher measuring range (order-related) than the permissible pressure range of the process fitting is installed.

2.7 NAMUR recommendations

NAMUR is the automation technology user association in the process industry in Germany. The published NAMUR recommendations are accepted as the standard in field instrumentation.

The device fulfills the requirements of the following NAMUR recommendations:

- NE 21 – Electromagnetic compatibility of equipment
- NE 43 – Signal level for malfunction information from measuring transducers
- NE 53 – Compatibility of field devices and display/adjustment components
- NE 107 – Self-monitoring and diagnosis of field devices

For further information see www.namur.de.

2.8 Environmental instructions

Protection of the environment is one of our most important duties. That is why we have introduced an environment management system with the goal of continuously improving company environmental protection. The environment management system is certified according to DIN EN ISO 14001.

Please help us fulfill this obligation by observing the environmental instructions in this manual:

- Chapter "*Packaging, transport and storage*"
- Chapter "*Disposal*"

3 Product description

3.1 Configuration

Type plate

The nameplate contains the most important data for identification and use of the instrument:



Fig. 1: Layout of the type label (example)

- 1 Instrument type
- 2 Product code
- 3 Field for approvals
- 4 Power supply and signal output, electronics
- 5 Protection rating
- 6 Measuring range
- 7 Permissible process pressure
- 8 Material, wetted parts
- 9 Hardware and software version
- 10 Order number
- 11 Serial number of the instrument
- 12 Symbol of the device protection class
- 13 ID numbers, instrument documentation
- 14 Reminder to observe the instrument documentation
- 15 Notified authority for CE marking
- 16 Approval directive

Serial number

The type label contains the serial number of the instrument. With it you can find the following data on our homepage:

- Product code of the instrument (HTML)
- Delivery date (HTML)
- Order-specific instrument features (HTML)
- Operating instructions at the time of shipment (PDF)
- Order-specific sensor data for an electronics exchange (XML)
- Test certificate pressure transmitters (PDF)

Go to www.vega.com, "VEGA Tools" and "Serial number search".

As an alternative, you can find the data via your Smartphone:

- Download the smartphone app "VEGA Tools" from the "Apple App Store" or the "Google Play Store"
- Scan the Data Matrix code on the type label of the instrument or
- Enter the serial number manually in the app

Scope of this operating instructions manual

This operating instructions manual applies to the following instrument versions:

- Hardware from 1.0.0
- Software version from 1.0.0

Scope of delivery

The scope of delivery encompasses:

- Pressure transmitter
- Documentation
 - this operating instructions manual
 - Test certificate, pressure transmitters
 - Operating instructions manual "*Display and adjustment module*" (optional)
 - Supplementary instructions "*GSM/GPRS radio module*" (optional)
 - Supplementary instructions manual "*Heating for display and adjustment module*" (optional)
 - Supplementary instructions manual "*Plug connector for continuously measuring sensors*" (optional)
 - Ex-specific "*Safety instructions*" (with Ex versions)
 - if necessary, further certificates

3.2 Principle of operation**Measured variables**

The VEGABAR 83 is suitable for the measurement of the following process variables:

- Process pressure
- Level

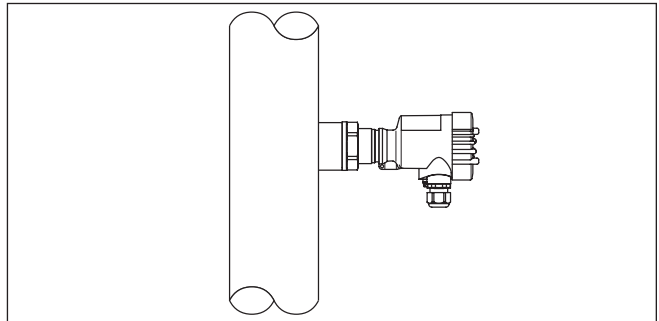

Fig. 2: Process pressure measurement VEGABAR 83

Electronic differential pressure

In combination with a slave sensor, VEGABAR 83 is also suitable for electronic differential pressure measurement.

You can find detailed information in the operating instructions of the respective slave sensor.

Application area

VEGABAR 83 is suitable for applications in virtually all industries. It is used for the measurement of the following pressure types.

- Gauge pressure

- Absolute pressure
- Vacuum

Measured products

Measured products are gases, vapours and liquids.

VEGABAR 83 is especially suitable for applications with higher temperatures and high pressures.

Measuring system

The process pressure acts on the sensor element via the process diaphragm and an internal transmission liquid. The process pressure causes a resistance change which is converted into a corresponding output signal and outputted as measured value.

Measuring ranges up to 16 bar: piezoresistive sensor element, measuring ranges up to 25 bar: strain gauge (DMS) sensor element.

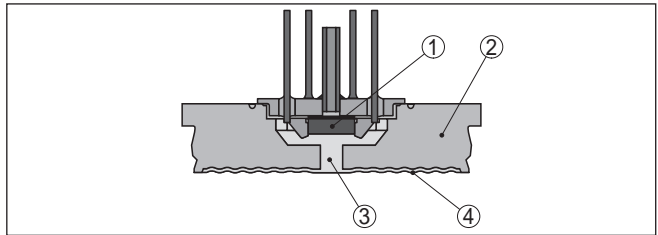

Fig. 3: Configuration of the measuring system with piezoresistive sensor element

- 1 Sensor element
- 2 Base element
- 3 Transmission liquid
- 4 Process diaphragm

With small measuring ranges or higher temperatures, the METEC® measuring cell is the measuring unit. It consists of the ceramic-capacitive CERTEC® measuring cell and a special, temperature-compensated chemical seal system.

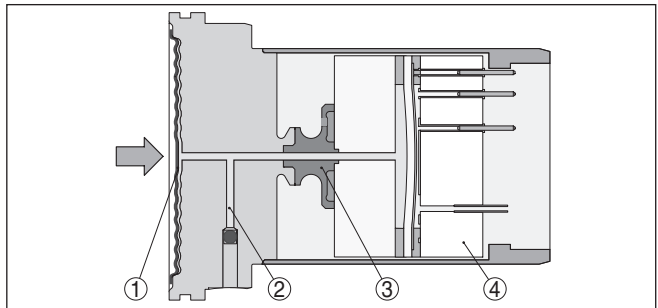

Fig. 4: Configuration of the METEC® measuring cell

- 1 Process diaphragm
- 2 Isolating liquid
- 3 FeNi adapter
- 4 CERTEC® measuring cell

Pressure types

The measuring cell design depends on the selected pressure type.

Relative pressure: the measuring cell is open to atmosphere. The ambient pressure is detected in the measuring cell and compensated. It thus has no influence on the measured value.

Absolute pressure: the measuring cell is evacuated and encapsulated. The ambient pressure is not compensated and does hence influence the measured value.

Relative pressure, climate-compensated: the measuring cell is evacuated and encapsulated. The ambient pressure is detected through a reference sensor in the electronics and compensated. It thus has no influence on the measured value.

Seal concept

The measuring system is completely welded and hence sealed against the process. The sealing of the process fitting against the process is carried out by a seal provided on site.

3.3 Packaging, transport and storage**Packaging**

Your instrument was protected by packaging during transport. Its capacity to handle normal loads during transport is assured by a test based on ISO 4180.

The packaging of standard instruments consists of environment-friendly, recyclable cardboard. For special versions, PE foam or PE foil is also used. Dispose of the packaging material via specialised recycling companies.

Transport

Transport must be carried out in due consideration of the notes on the transport packaging. Nonobservance of these instructions can cause damage to the device.

Transport inspection

The delivery must be checked for completeness and possible transit damage immediately at receipt. Ascertained transit damage or concealed defects must be appropriately dealt with.

Storage

Up to the time of installation, the packages must be left closed and stored according to the orientation and storage markings on the outside.

Unless otherwise indicated, the packages must be stored only under the following conditions:

- Not in the open
- Dry and dust free
- Not exposed to corrosive media
- Protected against solar radiation
- Avoiding mechanical shock and vibration

Storage and transport temperature

- Storage and transport temperature see chapter "*Supplement - Technical data - Ambient conditions*"
- Relative humidity 20 ... 85 %

3.4 Accessories and replacement parts

PLICSCOM	<p>The display and adjustment module PLICSCOM is used for measured value indication, adjustment and diagnosis. It can be inserted into the sensor or the external display and adjustment unit and removed at any time.</p> <p>You can find further information in the operating instructions "<i>Display and adjustment module PLICSCOM</i>" (Document-ID 27835).</p>
VEGACONNECT	<p>The interface adapter VEGACONNECT enables the connection of communication-capable instruments to the USB interface of a PC. For parameter adjustment of these instruments, the adjustment software PACTware with VEGA-DTM is required.</p> <p>You can find further information in the operating instructions "<i>Interface adapter VEGACONNECT</i>" (Document-ID 32628).</p>
Slave sensors	<p>Slave sensors of VEGABAR series 80 enable in conjunction with VEGABAR 83 an electronic differential pressure measurement.</p> <p>You can find further information in the operating instructions of the respective slave sensor.</p>
VEGADIS 81	<p>The VEGADIS 81 is an external display and adjustment unit for VEGA plics[®] sensors.</p> <p>For sensors with double chamber housing the interface adapter "<i>DIS-ADAPT</i>" is also required for VEGADIS 81.</p> <p>You can find further information in the operating instructions "<i>VEGADIS 81</i>" (Document-ID 43814).</p>
DIS-ADAPT	<p>The adapter "<i>DIS-ADAPT</i>" is an accessory part for sensors with double chamber housings. It enables the connection of VEGADIS 81 to the sensor housing via an M12 x 1 plug.</p> <p>You can find further information in the supplementary instructions "<i>Adapter DISADAPT</i>" (Document-ID 45250).</p>
VEGADIS 62	<p>VEGADIS 62 is suitable for measured value indication and adjustment of sensors with HART protocol. It is looped into the 4 ... 20 mA/HART signal cable.</p> <p>You can find further information in the operating instructions "<i>VEGADIS 62</i>" (Document-ID 36469).</p>
PLICSMOBILE T61	<p>The PLICSMOBILE T61 is an external GSM/GPRS radio unit for transmission of measured values and for remote parameter adjustment of plics[®] sensors. The adjustment is carried out via PACTware/DTM by using the integrated USB connection.</p> <p>You can find further information in the supplementary instructions "<i>PLICSMOBILE T61</i>" (Document-ID 37700).</p>
Protective cap	<p>The protective cover protects the sensor housing against soiling and intense heat from solar radiation.</p>

You will find additional information in the supplementary instructions manual "*Protective cover*" (Document-ID 34296).

Flanges

Screwed flanges are available in different versions according to the following standards: DIN 2501, EN 1092-1, BS 10, ANSI B 16.5, JIS B 2210-1984, GOST 12821-80.

You can find additional information in the supplementary instructions manual "*Flanges according to DIN-EN-ASME-JIS*" (Document-ID 31088).

Welded socket

Welded sockets are used to connect the sensors to the process.

You can find further information in the supplementary instructions "*Welded socket VEGABAR series 80*" (Document-ID 45082).

Electronics module

The electronics module VEGABAR series 80 is a replacement part for pressure transmitters of VEGABAR series 80. There is a different version available for each type of signal output.

You can find further information in the operating instructions "*Electronics module VEGABAR series 80*" (Document-ID 45054).

Supplementary electronics for double chamber housing

The supplementary electronics is a replacement part for sensors with double chamber housing and 4 ... 20 mA/HART - two-wire.

You can find further information in the operating instructions "*Supplementary electronics for 4 ... 20 mA/HART - two-wire*" (Document-ID 42764).

4 Mounting

4.1 General instructions to use the instrument

Suitability for the process conditions

Make sure that all parts of the instrument exposed to the process are suitable for the existing process conditions.

These are mainly:

- Active measuring component
- Process fitting
- Process seal

Process conditions are particularly:

- Process pressure
- Process temperature
- Chemical properties of the medium
- Abrasion and mechanical influences

You can find the specifications of the process conditions in chapter "*Technical data*" as well as on the nameplate.

Protection against moisture

Protect your instrument further through the following measures against moisture penetration:

- Use the recommended cable (see chapter "*Connecting to power supply*")
- Tighten the cable gland
- Loop the connection cable downward in front of the cable gland

This applies particularly to:

- Outdoor mounting
- Installations in areas where high humidity is expected (e.g. through cleaning processes)
- Installations on cooled or heated vessels

Screwing in

On instruments with process fitting thread, the hexagon must be tightened with a suitable screwdriver. Wrench size see chapter "*Dimensions*".



Warning:

The housing must not be used to screw the instrument in! Applying tightening force can damage internal parts of the housing.

Vibrations

In case of strong vibrations at the mounting location, the instrument version with external housing should be used. See chapter "*External housing*".

Temperature limits

Higher process temperatures often mean also higher ambient temperatures. Make sure that the upper temperature limits stated in chapter "*Technical data*" for the environment of the electronics housing and connection cable are not exceeded.

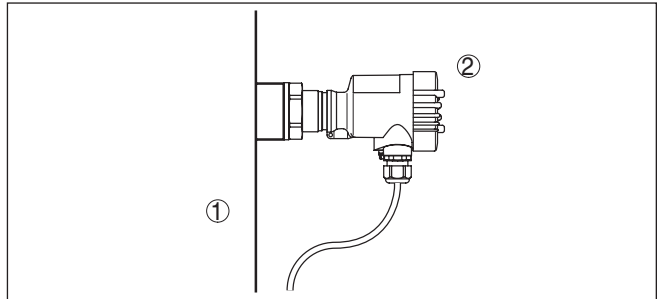

Fig. 5: Temperature ranges

- 1 Process temperature
2 Ambient temperature

Filter elements

4.2 Ventilation and pressure compensation

Ventilation and pressure compensation are carried out with VEGABAR 83 via a filter element. It is air permeable and moisture-blocking.



Caution:

The filter element causes a time-delayed pressure compensation. When quickly opening/closing the housing cover, the measured value can change for approx. 5 s by up to 15 mbar.

For effective ventilation, the filter element must always be free of buildup.



Caution:

Do not use a high-pressure cleaner. The filter element could be damaged, which would allow moisture into the housing.

The following paragraphs describe how the filter element is arranged in the different instrument versions.

Instruments in non-Ex, Ex-ia and Ex-d-ia version

The filter element is mounted into the electronics housing. It has the following functions:

- Ventilation electronics housing
- Atmospheric pressure compensation (with relative pressure measuring ranges)

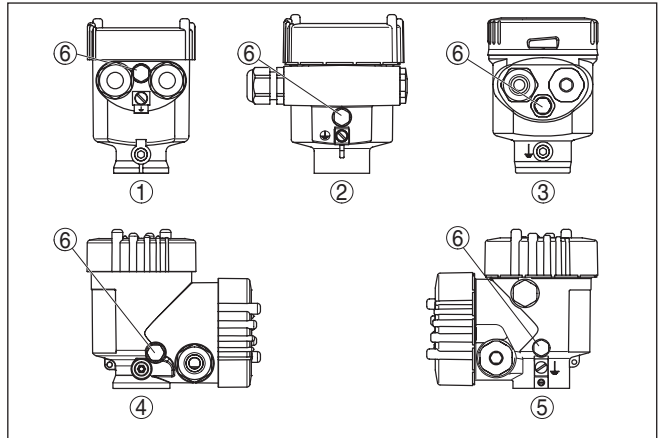

Fig. 6: Position of the filter element - non-Ex, Ex-ia and Ex-d-ia version

- 1 Single chamber housing plastic, stainless steel (precision casting)
- 2 Single chamber housing Aluminium
- 3 Single chamber housing, stainless steel electropolished
- 4 Double chamber housing plastic
- 5 Double chamber housing Aluminium
- 6 Filter element

With the following instruments a blind plug is installed instead of the filter element:

- Instruments in protection IP 66/IP 68 (1 bar) - ventilation via capillaries in fix connected cable
- Instruments with absolut pressure

Instruments in Ex-d version

The filter element is integrated in the process assembly. It is located in a rotatable metal ring and has the following function:

- Atmospheric pressure compensation (with relative pressure measuring ranges)

Turn the metal ring in such a way that the filter element points downward after installation of the instrument. This provides better protection against buildup.

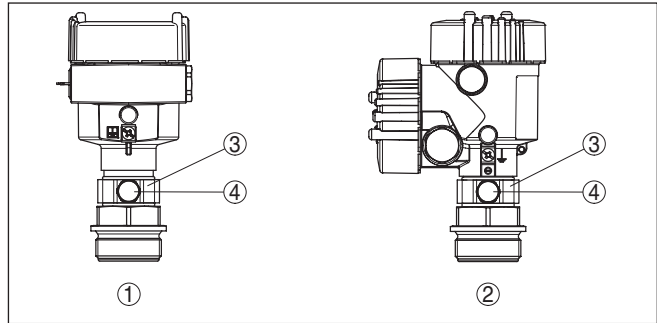

Fig. 7: Position of the filter element - Ex-d version

- 1 Single chamber housing, aluminium, stainless steel precision casting
- 2 Double chamber housing, aluminium, stainless steel precision casting
- 3 Rotatable metal ring
- 4 Filter element

Instruments with absolute pressure have a blind plug mounted instead of the filter element.

Instruments with Second Line of Defense

The filter element is mounted into the electronics housing. It has the following functions:

- Ventilation electronics housing
- Atmospheric pressure compensation (with relative pressure measuring ranges)

The process assembly of instruments with Second Line of Defense (gastight leadthrough) is completely encapsulated. An absolute pressure measuring cell is used so that no ventilation is required.

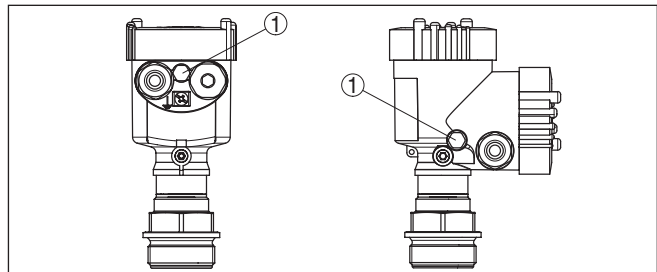

Fig. 8: Position of the filter element - gastight leadthrough

- 1 Filter element

With relative pressure measuring ranges, the ambient pressure is detected and compensated by a reference sensor in the electronics.

Instruments in IP 69K version

The filter element is mounted into the electronics housing. It has the following functions:

- Ventilation electronics housing
- Atmospheric pressure compensation (with relative pressure measuring ranges)

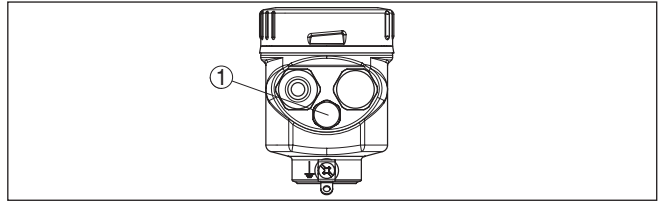

Fig. 9: Position of the filter element - IP 69K version

1 Filter element

Instruments with absolute pressure have a blind plug mounted instead of the filter element.

4.3 Process pressure measurement

Measurement setup in gases

Keep the following in mind when setting up the measuring system:

- Mount the instrument above the measuring point

Possible condensation can then drain off into the process line.

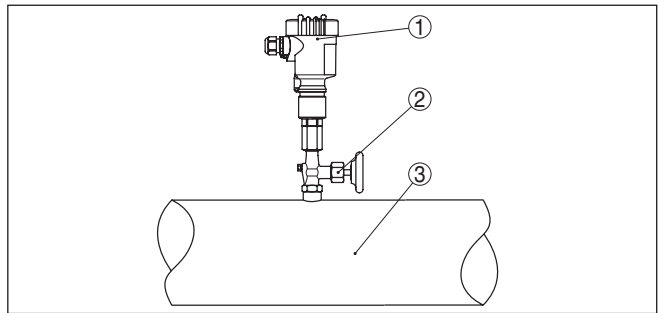

Fig. 10: Measurement setup for process pressure measurement of gases in pipelines

1 VEGABAR 83
 2 Blocking valve
 3 Pipeline

Measurement setup in vapours

Keep the following in mind when setting up the measuring system:

- Connect via a siphon
- Do not insulate the siphon
- Fill the siphon with water before setup

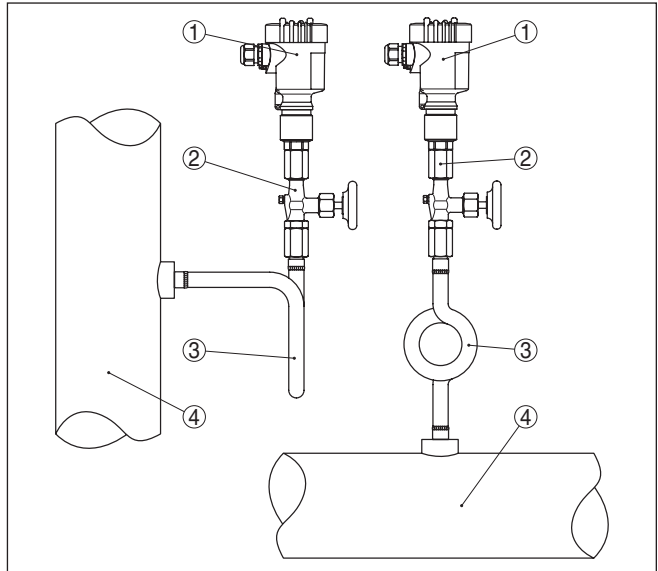

Fig. 11: Measurement setup with process pressure measurement of gases in pipelines

- 1 VEGABAR 83
- 2 Blocking valve
- 3 Siphon
- 4 Pipeline

A protective accumulation of water is formed through condensation in the pipe bends. Even in applications with hot steam, a medium temperature < 100 °C on the transmitter is ensured.

Measurement setup in liquids

Keep the following in mind when setting up the measuring system:

- Mount the instrument below the measuring point

The effective pressure line is always filled with liquid and gas bubbles can bubble up to the process line.

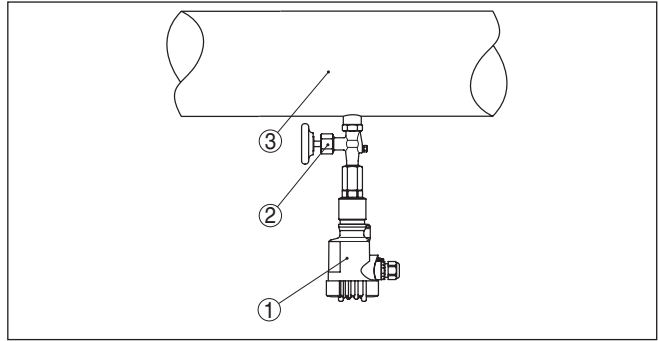

Fig. 12: Measurement setup for process pressure measurement of liquids in pipelines

- 1 VEGABAR 83
- 2 Blocking valve
- 3 Pipeline

4.4 Level measurement

Measurement setup

Keep the following in mind when setting up the measuring system:

- Mount the instrument below the min. level
- Do not mount the instrument close to the filling stream or emptying area
- Mount the instrument so that it is protected against pressure shocks from the stirrer

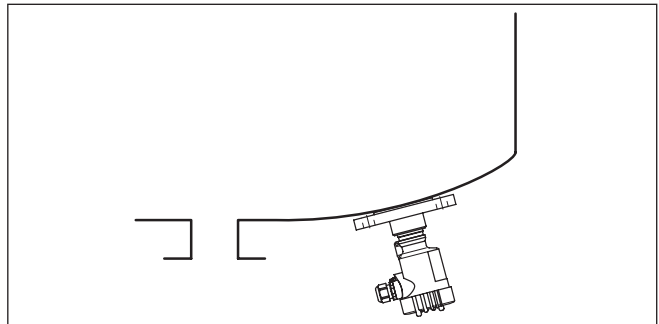

Fig. 13: Measurement setup for level measurement

4.5 External housing

Configuration

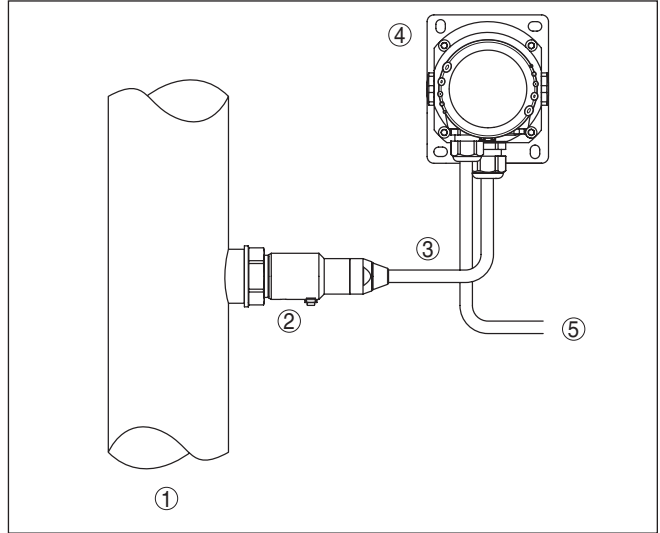

Fig. 14: Setup process assembly, external housing

- 1 Process assembly
- 2 Connection cable process assembly - External housing
- 3 External housing
- 4 Signal cable

Mounting

1. Mark the holes according to the following drilling template
2. Fasten wall mounting plate with 4 screws

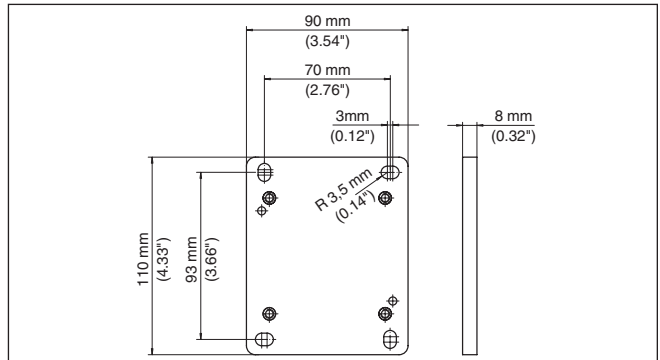

Fig. 15: Drilling template - wall mounting plate

5 Connecting to power supply

5.1 Preparing the connection

Safety instructions

Always keep in mind the following safety instructions:

- Connect only in the complete absence of line voltage
- If overvoltage surges are expected, overvoltage arresters should be installed

Voltage supply

Power supply and current signal are carried on the same two-wire cable. The operating voltage can differ depending on the instrument version.

The data for power supply are specified in chapter "*Technical data*".

Provide a reliable separation between the supply circuit and the mains circuits according to DIN EN 61140 VDE 0140-1.

Keep in mind the following additional factors that influence the operating voltage:

- Lower output voltage of the power supply unit under nominal load (e.g. with a sensor current of 20.5 mA or 22 mA in case of fault message)
- Influence of additional instruments in the circuit (see load values in chapter "*Technical data*")

Connection cable

The instrument is connected with standard two-wire cable without screen. If electromagnetic interference is expected which is above the test values of EN 61326-1 for industrial areas, screened cable should be used.

Use cable with round cross section for instruments with housing and cable gland. To ensure the seal effect of the cable gland (IP protection rating), find out which cable outer diameter the cable gland is suitable for.

- 5 ... 9 mm (0.20 ... 0.35 in)
- 6 ... 12 mm (0.24 ... 0.47 in)
- 10 ... 14 mm (0.40 ... 0.55 in)

Use a cable gland fitting the cable diameter.

We generally recommend the use of screened cable for HART multi-drop mode.

Cable gland ½ NPT

With plastic housing, the NPT cable gland or the Conduit steel tube must be screwed without grease into the threaded insert.

Max. torque for all housings see chapter "*Technical data*".

Cable screening and grounding

If screened cable is required, we recommend connecting the cable screen on both ends to ground potential. In the sensor, the screen must be connected directly to the internal ground terminal. The ground terminal on the outside of the housing must be connected to the ground potential (low impedance).



With Ex systems it must be ensured that the grounding corresponds to the installation regulations.

In electroplating and CCP systems (cathodic corrosion protection) it must be taken into account that significant potential differences exist. This can lead to unacceptably high shield currents if the cable shield is grounded at both ends.



Information:

The metallic parts of the instrument (process fitting, transmitter, concentric tube, etc.) are conductively connected with the inner and outer ground terminal on the housing. This connection exists either directly via connecting metallic parts or, in case of instruments with external electronics, via the screen of the special connection cable.

You can find specifications on the potential connections inside the instrument in chapter "Technical data".

5.2 Connecting

Connection technology

The voltage supply and signal output are connected via the spring-loaded terminals in the housing.

The connection to the display and adjustment module or to the interface adapter is carried out via contact pins in the housing.



Information:

The terminal block is pluggable and can be removed from the electronics. To do this, lift the terminal block with a small screwdriver and pull it out. When reinserting the terminal block, you should hear it snap in.

Connection procedure

Proceed as follows:

1. Unscrew the housing cover
2. If a display and adjustment module is installed, remove it by turning it slightly to the left.
3. Loosen compression nut of the cable entry
4. Remove approx. 10 cm (4 in) of the cable mantle, strip approx. 1 cm (0.4 in) of insulation from the ends of the individual wires
5. Insert the cable into the sensor through the cable entry



Fig. 16: Connection steps 5 and 6 - Single chamber housing



Fig. 17: Connection steps 5 and 6 - Double chamber housing

6. Insert the wire ends into the terminals according to the wiring plan



Information:

Solid cores as well as flexible cores with wire end sleeves are inserted directly into the terminal openings. In case of flexible cores without end sleeves, press the terminal from above with a small screwdriver; the terminal opening is freed. When the screwdriver is released, the terminal closes again.

You can find further information on the max. wire cross-section under "*Technical data/Electromechanical data*"

7. Check the hold of the wires in the terminals by lightly pulling on them
8. Connect the screen to the internal ground terminal, connect the outer ground terminal to potential equalisation
9. Tighten the compression nut of the cable entry. The seal ring must completely encircle the cable
10. Reinsert the display and adjustment module, if one was installed
11. Screw the housing cover back on

The electrical connection is hence finished.

5.3 Single chamber housing



The following illustration applies to the non-Ex, Ex-ia, Ex-d and Ex-d-ia version.

Electronics and connection compartment

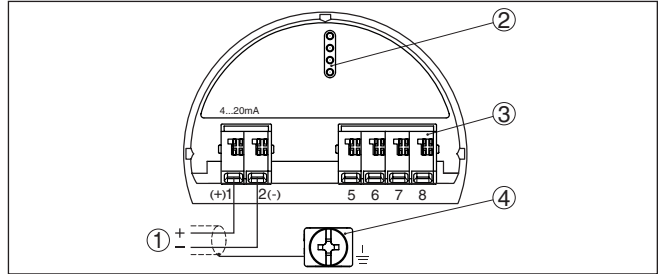

Fig. 18: Electronics and connection compartment, single chamber housing

- 1 Voltage supply/Signal output
- 2 For display and adjustment module or interface adapter
- 3 For external display and adjustment unit or Slave sensor
- 4 Ground terminal for connection of the cable screen

5.4 Double chamber housing



The following illustrations apply to the non-Ex as well as to the Ex-ia version.

Electronics compartment

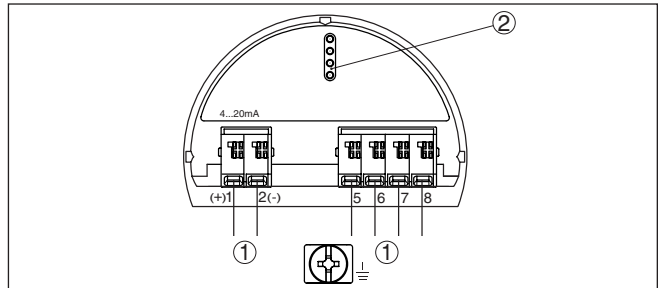

Fig. 19: Electronics compartment, double chamber housing

- 1 Internal connection to the connection compartment
- 2 For display and adjustment module or interface adapter



Information:

The connection of an external display and adjustment unit is not possible with this double chamber housing.

Connection compartment

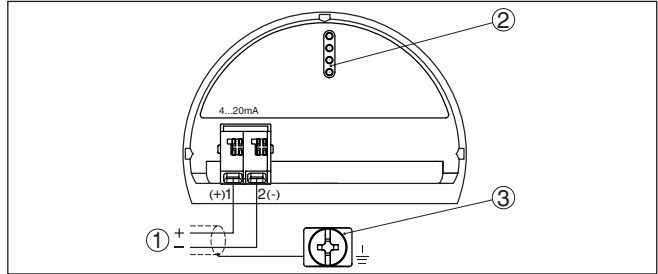

Fig. 20: Connection compartment, double chamber housing

- 1 Voltage supply/Signal output
- 2 For display and adjustment module or interface adapter
- 3 Ground terminal for connection of the cable screen

Connection compartment
- Second current output

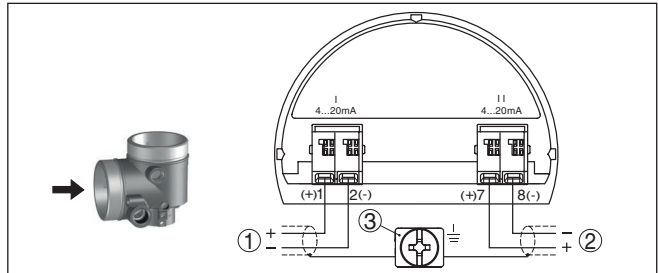

Fig. 21: Connection compartment double chamber housing, supplementary electronics - second current output

- 1 First current output (I) - Voltage supply and signal output (HART)
- 2 Second current output (II) - Voltage supply and signal output (without HART)
- 3 Ground terminal for connection of the cable screen

Connection compartment
- Radio module PLICS-
MOBILE

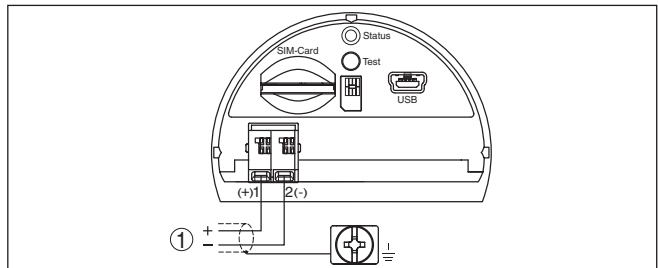

Fig. 22: Connection compartment radio module PLICSMOBILE

- 1 Voltage supply

You can find detailed information on connection in the supplementary instructions "PLICSMOBILE GSM/GPRS radio module".

5.5 Double chamber housing Ex d

Electronics compartment

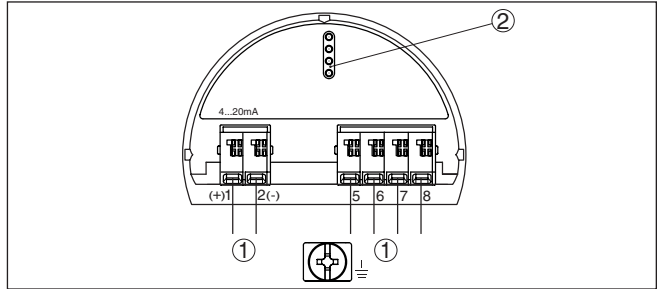

Fig. 23: Electronics compartment, double chamber housing Ex d

- 1 Internal connection to the connection compartment
- 2 For display and adjustment module or interface adapter

Connection compartment

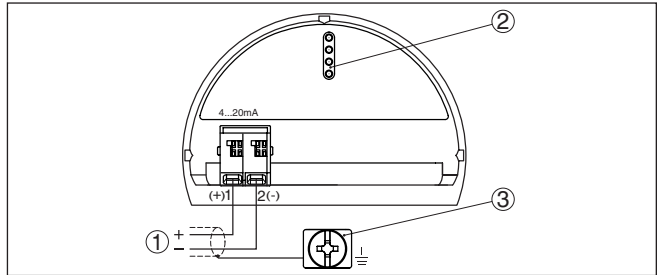

Fig. 24: Connection compartment, double chamber housing

- 1 Voltage supply/Signal output
- 2 For display and adjustment module or interface adapter
- 3 Ground terminal for connection of the cable screen

5.6 Double chamber housing Ex d ia

Electronics compartment

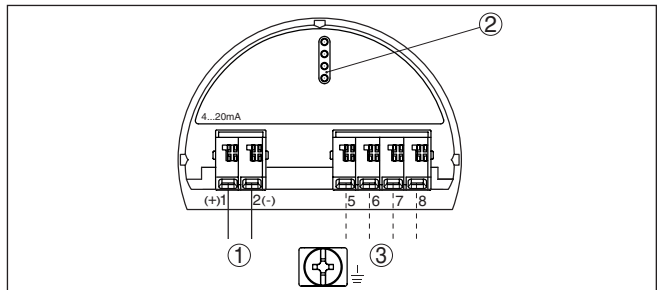

Fig. 25: Electronics compartment, double chamber housing Ex d ia

- 1 Internal connection to the connection compartment
- 2 For display and adjustment module or interface adapter
- 3 Internal connection to the plug connector for external display and adjustment unit (optional)



Note:

If an instrument with Ex-d-ia approval is used, HART multidrop operation is not possible.

Connection compartment

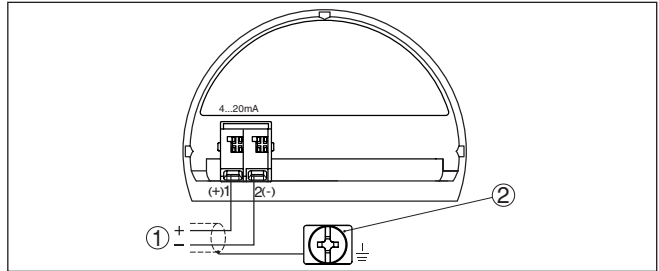

Fig. 26: Connection compartment, Ex-d double chamber housing

- 1 Voltage supply, signal output
- 2 Ground terminal for connection of the cable screen

5.7 Double chamber housing with DIS-ADAPT

Electronics compartment

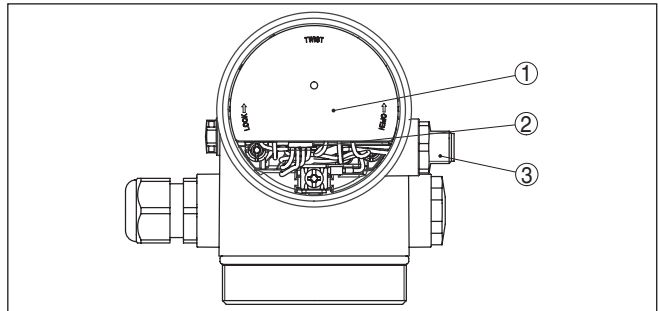

Fig. 27: View to the electronics compartment

- 1 DIS-ADAPT
- 2 Internal plug connection
- 3 Plug connector M12 x 1

Assignment of the plug connector

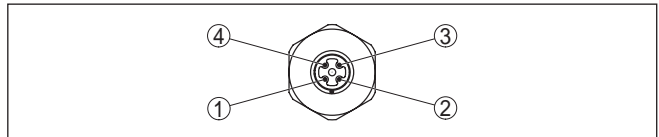

Fig. 28: Top view of the plug connector

- 1 Pin 1
- 2 Pin 2
- 3 Pin 3
- 4 Pin 4

Contact pin	Colour connection cable in the sensor	Terminal, electronics module
Pin 1	Brown	5
Pin 2	White	6
Pin 3	Blue	7
Pin 4	Black	8

Wire assignment, connection cable

5.8 Housing IP 66/IP 68 (1 bar)

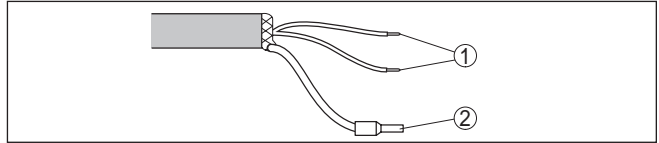

Fig. 29: Wire assignment fix-connected connection cable

- 1 brown (+) and blue (-) to power supply or to the processing system
- 2 Shielding

Overview

5.9 External housing with version IP 68 (25 bar)

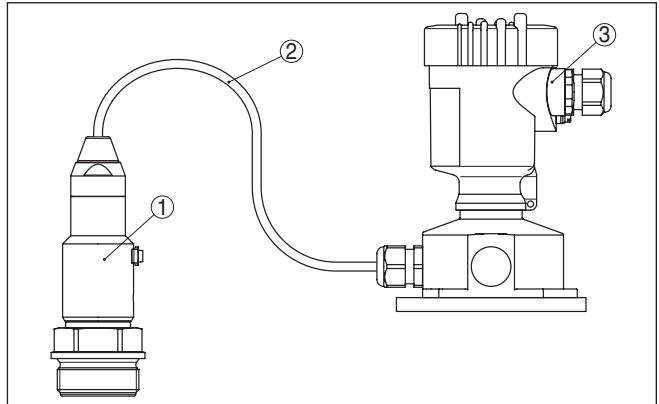

Fig. 30: VEGABAR 83 in IP 68 version 25 bar with axial cable outlet, external housing

- 1 Transmitter
- 2 Connection cable
- 3 External housing

Electronics and connection compartment for power supply

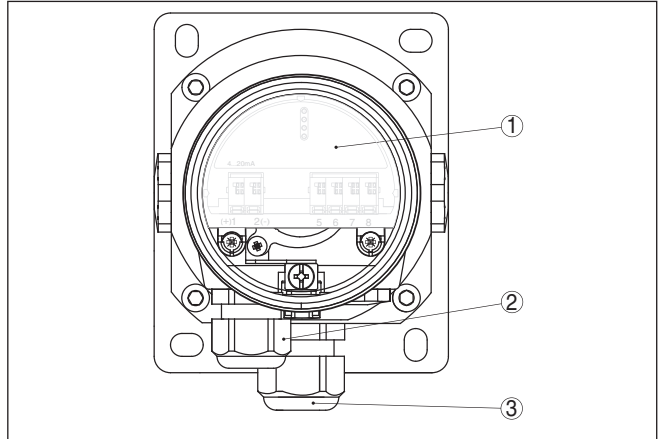

Fig. 31: Electronics and connection compartment

- 1 Electronics module
- 2 Cable gland for voltage supply
- 3 Cable gland for connection cable, transmitter

Terminal compartment, housing socket

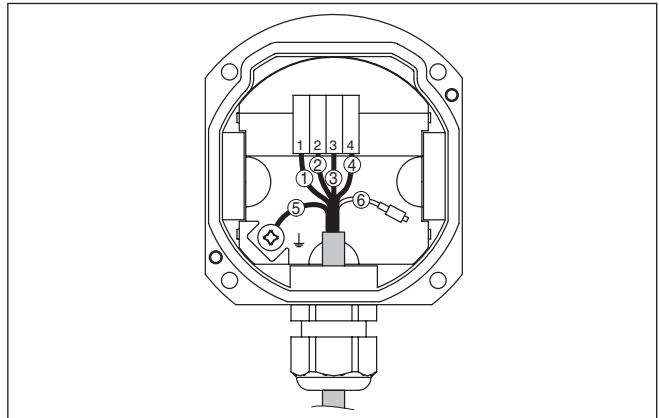

Fig. 32: Connection of the sensor in the housing base

- 1 Brown
- 2 Blue
- 3 Yellow
- 4 White
- 5 Shielding
- 6 Breather capillaries

Electronics and connection compartment

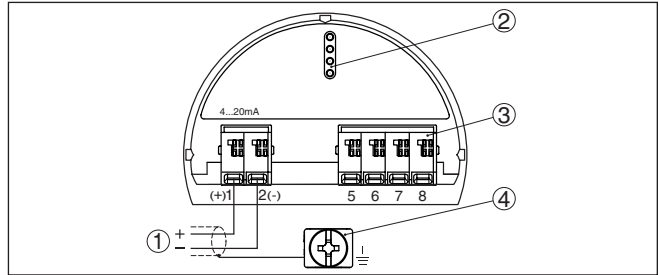

Fig. 33: Electronics and connection compartment, single chamber housing

- 1 Voltage supply/Signal output
- 2 For display and adjustment module or interface adapter
- 3 For external display and adjustment unit or Slave sensor
- 4 Ground terminal for connection of the cable screen

5.10 Switch-on phase

After connecting the instrument to power supply or after a voltage recurrence, the instrument carries out a self-check for approx. 10 s:

- Internal check of the electronics
- Indication of the instrument type, hardware and software version, measurement loop name on the display or PC
- Indication of a status message on the display or PC
- The output signal jumps to the set error current

Then the actual measured value is outputted to the signal cable. The value takes already carried out settings, e.g. default setting into account.

6 Set up with the display and adjustment module

6.1 Insert display and adjustment module

The display and adjustment module can be inserted into the sensor and removed any time. Four positions displaced by 90° can be selected. It is not necessary to interrupt the power supply.

Proceed as follows:

1. Unscrew the housing cover
2. Place the display and adjustment module in the requested position onto the electronics and turn to the right until it snaps in
3. Screw housing cover with inspection window tightly back on

Removal is carried out in reverse order.

The display and adjustment module is powered by the sensor, an additional connection is not necessary.



Fig. 34: Insertion of the display and adjustment module with single chamber housing into the electronics compartment

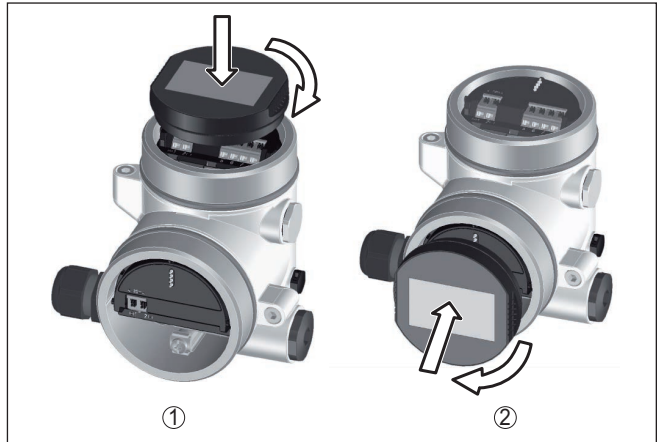

Fig. 35: Insertion of the display and adjustment module into the double chamber housing

- 1 In the electronics compartment
- 2 In the connection compartment (with Ex-d-ia version not possible)



Note:

If you intend to retrofit the instrument with a display and adjustment module for continuous measured value indication, a higher cover with an inspection glass is required.

6.2 Adjustment system

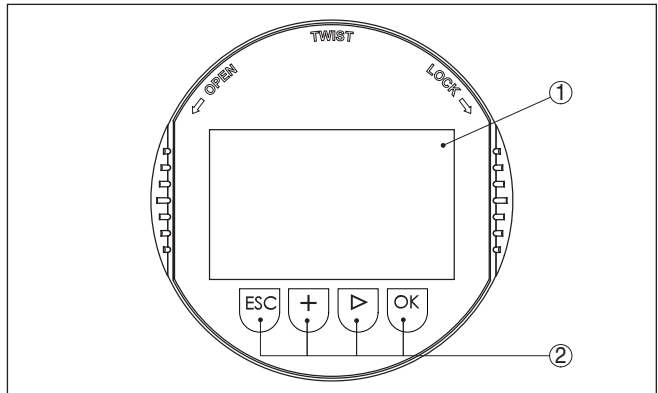

Fig. 36: Display and adjustment elements

- 1 LC display
- 2 Adjustment keys

Key functions

- **[OK]** key:
 - Move to the menu overview
 - Confirm selected menu
 - Edit parameter

- Save value
- [->] key:
 - Presentation, change measured value
 - Select list entry
 - Select editing position
- [+] key:
 - Change value of the parameter
- [ESC] key:
 - Interrupt input
 - Jump to next higher menu

Adjustment system

The sensor is adjusted via the four keys of the display and adjustment module. The LC display indicates the individual menu items. The functions of the individual keys are shown in the above illustration. Approx. 60 minutes after the last pressing of a key, an automatic reset to measured value indication is triggered. Any values not confirmed with [OK] will not be saved.

6.3 Parameter adjustment - Quick setup

To quickly and easily adapt the sensor to the application, select the menu item "Quick setup" in the start graphic on the display and adjustment module.



Carry out the following steps in the below sequence.

You can find "Extended adjustment" in the next sub-chapter.

Presettings

1. Measurement loop name

In the first menu item you assign a suitable measurement loop name. Permitted are names with max. 19 characters.

2. Application

In this menu item you activate/deactivate the slave for the electronic differential pressure and select the application. With process pressure transmitters, the selection comprises process pressure and level measurement; with suspension pressure transmitters it comprises level measurement.

3. Units

In this menu item you determine the adjustment and temperature units of the instrument. Depending on the selected application in the menu item "Application", different adjustment units are available.

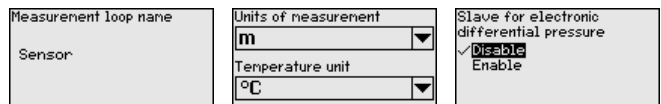

Adjustment - Process pressure measurement**4. Position correction**

In this menu item you compensate the influence of the installation position of the instrument (offset) to the measured value.

5. zero adjustment

In this menu item you carry out the zero adjustment for the process pressure.

Enter the respective pressure value for 0 %.

6. span adjustment

In this menu item you carry out the span adjustment for the process pressure

Enter the respective pressure value for 100 %.

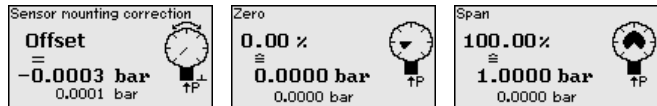
**Adjustment - Level measurement****4. Position correction**

In this menu item you compensate the influence of the installation position of the instrument (offset) to the measured value.

5. Max. adjustment

In this menu item you carry out the max. adjustment for level

Enter the percentage value and the corresponding value for the max. level.

6. Min. adjustment

In this menu item you carry out the min. adjustment for level

Enter the percentage value and the corresponding value for the min. level.



The quick setup is hence finished.

6.4 Parameter adjustment - Extended adjustment

For technically demanding measurement loops you can carry out extended settings in "Extended adjustment".

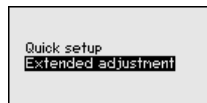
**Main menu
Main menu**

The main menu is divided into five sections with the following functions:

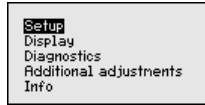

Setup: Settings, e.g., for measurement loop name, application, units, position correction, adjustment, signal output

Display: Settings, e.g., for language, measured value display, lighting

Diagnosis: Information, e.g. on instrument status, pointer, measurement reliability, simulation

Additional adjustments: PIN, date/time, reset, copy function

Info: Instrument name, hardware and software version, date of manufacture, sensor features

In the main menu item "Setup", the individual submenu items should be selected one after the other and provided with the correct parameter values.

The following submenu points are available:

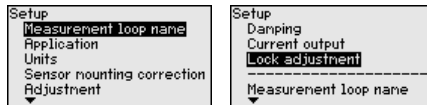

In the following paragraphs the menu items of the menu "Setup" for electronic differential pressure measurement are described. Depending on the selected application, different paragraphs are important. The additional menu items of the menu "Setup" as well as the complete menus "Display", "Diagnostics", "Additional settings" and "Info" are described in the operating instructions of the master sensor.

Setup - Measurement loop name

In the menu item "Sensor TAG" you edit a twelve digit measurement loop designation label.

You can enter an unambiguous designation for the sensor, e.g. the measurement loop name or the tank or product designation. In digital systems and in the documentation of larger plants, a singular designation must be entered for exact identification of individual measuring points.

The available digits comprise:

- Letters from A ... Z
- Numbers from 0 ... 9
- Special characters +, -, /, -

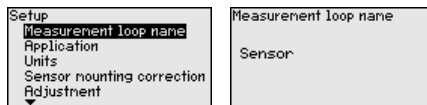

Setup - Application

In this menu item you activate/deactivate the slave for electronic differential pressure and select the application.

If you have connected a slave sensor, you confirm this with "Activate".

If you have connected **no** slave sensor, you confirm this with "*Deactivate*".

VEGABAR 83 can be used for process pressure and level measurement. Default setting is process pressure measurement. The mode can be changed in this adjustment menu.

The VEGABAR 83 in conjunction with a slave sensor can be used for flow, differential pressure, density and interface measurement. The default setting is differential pressure measurement. Switchover is carried out in the adjustment menu.

Depending on the selected application, different subchapters in the following adjustment steps are important. There you can find the individual adjustment steps.

Setup Measurement loop name Application Units Sensor mounting correction Adjustment	Slave for electronic differential pressure <input checked="" type="checkbox"/> Disable Enable	Slave for electronic differential pressure Disabled! Application Pressure
---	--	--

Enter the requested parameters via the appropriate keys, save your settings with **[OK]** and jump to the next menu item with the **[ESC]** and the **[->]** key.

Setup - Units

In this menu item, the adjustment units of the instrument are determined. The selection determines the displayed unit in the menu items "*Min. adjustment (zero)*" and "*Max. adjustment (span)*".

Unit of measurement:

Units of measurement m Temperature unit °C	Units of measurement mbar <input checked="" type="checkbox"/> bar Pa kPa MPa	Units of measurement psi mmH2O <input checked="" type="checkbox"/> mmHg inH2O inHg
---	--	--

If the level should be adjusted in a height unit, the density of the medium must also be entered later during the adjustment.

In addition, the temperature unit of the instrument is specified. The selection determines the displayed unit in the menu items "*Peak value, measuring cell temperature*", "*Peak value, electronics temperature*" as well as "*HART variables*".

Temperature unit:

Units of measurement m Temperature unit °C	Temperature unit <input checked="" type="checkbox"/> °C K °F
---	--

Enter the requested parameters via the appropriate keys, save your settings with **[OK]** and jump to the next menu item with the **[ESC]** and the **[->]** key.

Setup - Position correction

Especially with chemical seal systems, the installation position of the instrument can shift (offset) the measured value. The position correction compensates this offset. Hence the actual measured value is taken over automatically. With relative pressure measuring cells also a manual offset can be carried out.

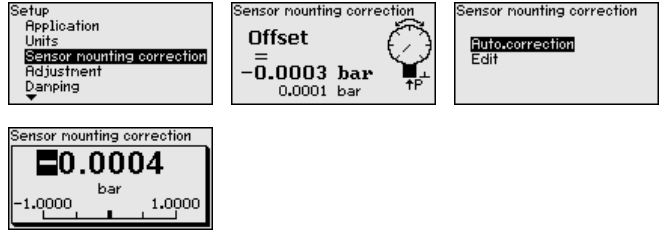

If with the automatic position correction, the actual measured value should be taken over as corrective value, then this value must not be influenced by product covering or a static pressure.

With the manual position correction, the offset value can be determined by the user. Select for this purpose the function "Edit" and enter the requested value.

Save your settings with [OK] and move with [ESC] and [->] to the next menu item.

When the position correction was carried out, then the actual measured value is corrected to 0. The corrective value appears with inverse signs as offset value in the display.

The position correction can be repeated as often as necessary. However, if the sum of the corrective values exceeds 20 % of the nominal measuring range, then no position correction is possible.

Setup - Adjustment

VEGABAR 83 always measures pressure independently of the process variable selected in the menu item "Application". To output the selected process variable correctly, an allocation to 0 % and 100 % of the output signal must be carried out (adjustment).

With the application "Level", the hydrostatic pressure, e.g. with full and empty vessel, is entered for adjustment. See following example:

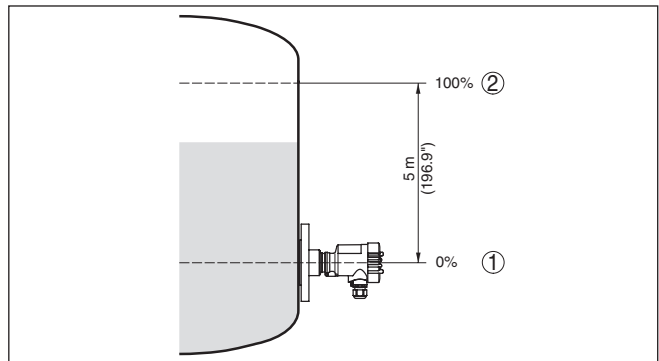

Fig. 37: Parameter adjustment example "Min./max. adjustment, level measurement"

- 1 Min. level = 0 % corresponds to 0.0 mbar
- 2 Max. level = 100 % corresponds to 490.5 mbar

If these values are not known, an adjustment with levels of for example 10 % and 90 % is also possible. By means of these settings, the real filling height is then calculated.

The real product level during this adjustment is not important, because the min./max. adjustment is always carried out without changing the product level. These settings can be made ahead of time without the instrument having to be installed.



Note:

If the adjustment ranges are exceeded, the entered value will not be accepted. Editing can be interrupted with **[ESC]** or corrected to a value within the adjustment ranges.

For the other process variables such as e.g. process pressure, differential pressure or flow, the adjustment is performed in like manner.

Setup - zero adjustment

Proceed as follows:

1. Select the menu item "Setup" with **[->]** and confirm with **[OK]**.
Now select with **[->]** the menu item "zero adjustment" and confirm with **[OK]**.



2. Edit the mbar value with **[OK]** and set the cursor to the requested position with **[->]**.

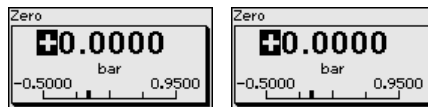

3. Set the requested mbar value with **[+]** and store with **[OK]**.
4. Move with **[ESC]** and **[->]** to the span adjustment

The zero adjustment is finished.



Information:

The zero adjustment shifts the value of the span adjustment. The span, i.e. the difference between these values, however, remains unchanged.

For an adjustment with pressure, simply enter the actual measured value indicated at the bottom of the display.

If the adjustment ranges are exceeded, the message "Outside parameter limits" appears. The editing procedure can be aborted with **[ESC]** or the displayed limit value can be accepted with **[OK]**.

Setup - span adjustment

Proceed as follows:

1. Select with **[->]** the menu item "Span adjustment" and confirm with **[OK]**.

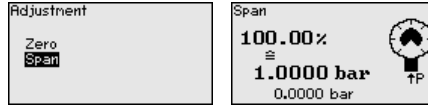

2. Edit the mbar value with **[OK]** and set the cursor to the requested position with **[->]**.

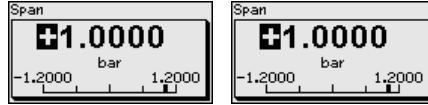

3. Set the requested mbar value with **[+]** and store with **[OK]**.

For an adjustment with pressure, simply enter the actual measured value indicated at the bottom of the display.

If the adjustment ranges are exceeded, the message "Outside parameter limits" appears. The editing procedure can be aborted with **[ESC]** or the displayed limit value can be accepted with **[OK]**.

The span adjustment is finished.

Setup - Min. adjustment Level

Proceed as follows:

1. Select the menu item "Setup" with **[->]** and confirm with **[OK]**. Now select with **[->]** the menu item "Adjustment", then "Min. adjustment" and confirm with **[OK]**.



2. Edit the percentage value with **[OK]** and set the cursor to the requested position with **[->]**.
3. Set the requested percentage value (e.g. 10 %) with **[+]** and save with **[OK]**. The cursor jumps now to the pressure value.
4. Enter the pressure value corresponding to the min. level (e.g. 0 mbar).
5. Save settings with **[OK]** and move with **[ESC]** and **[->]** to the max. adjustment.

The min. adjustment is finished.

For an adjustment with filling, simply enter the actual measured value indicated at the bottom of the display.

If the adjustment ranges are exceeded, then the entered value will not be taken over. Editing can be interrupted with **[ESC]** or corrected to a value within the adjustment ranges.

Setup - Max. adjustment Level

Proceed as follows:

1. Select with **[->]** the menu item max. adjustment and confirm with **[OK]**.

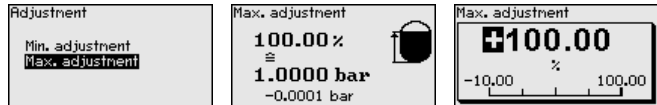

- Edit the percentage value with **[OK]** and set the cursor to the requested position with **[->]**.
- Set the requested percentage value (e.g. 90 %) with **[+]** and save with **[OK]**. The cursor jumps now to the pressure value.
- Enter the pressure value for the full vessel (e.g. 900 mbar) suitable for the percentage value.
- Save settings with **[OK]**

The max. adjustment is finished.

For an adjustment with filling, simply enter the actual measured value indicated at the bottom of the display.

If the adjustment ranges are exceeded, then the entered value will not be taken over. Editing can be interrupted with **[ESC]** or corrected to a value within the adjustment ranges.

Setup - Damping

To damp process-dependent measured value fluctuations, set an integration time of 0 ... 999 s in this menu item. The increment is 0.1 s.

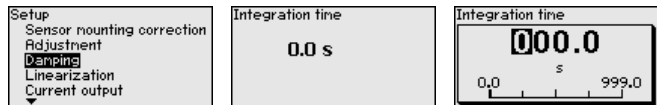

Depending on the sensor type, the factory setting is 0.1 s.

Setup - Linearization

A linearization is necessary for all vessels in which the vessel volume does not increase linearly with the level - e.g. a horizontal cylindrical or spherical tank - and the indication or output of the volume is required. Corresponding linearization curves are preprogrammed for these vessels. They represent the correlation between the level percentage and vessel volume. The linearization applies to the measured value indication and the current output.

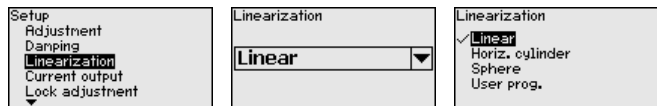

Caution:

Note the following, if the respective sensor is used as part of an over-fill protection system according to WHG:

If a linearization curve is selected, the measuring signal is no longer necessarily linear to the filling height. This must be considered by the user especially when adjusting the switching point on the limit signal transmitter.

Setup - Scaling (1)

In menu item "Scaling" you define the scaling variable and the scaling unit for the level value on the display, e.g. volume in l.

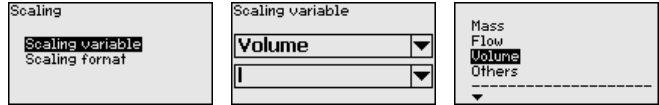

Setup - Scaling (2)

In menu item "Scaling (2)" you define the scaling format on the display and the scaling of the measured level value for 0 % and 100 %.



Setup - Current output

In the menu items "Current output" you determine the properties of the current output.

On instruments with integrated 2. current output, the properties for each current output are adjusted individually. The following descriptions apply to both current outputs.

Additional settings - Current output 1 and 2 (size)

In menu item "Current output, size" you determine which measured value the current output refers to.

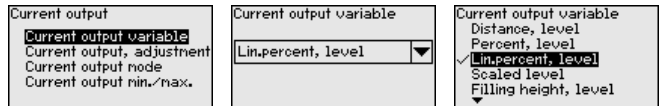

Additional settings - Current output 1 and 2 (adjustment)

In menu item "Current output, adjustment" you can assign a respective measured value to the current output.

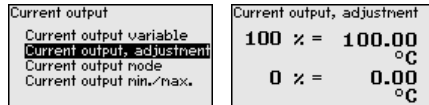

Setup - Current output 1 and 2 (mode)

In the menu item "Current output mode" you determine the output characteristics and reaction of the current output in case of failure.

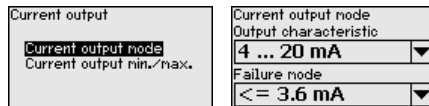

The default setting is output characteristics 4 ... 20 mA, failure mode < 3.6 mA.

Setup - Current output 1 and 2 (min./max.)

In the menu item "Current output Min./Max.", you determine the reaction of the current output during operation.

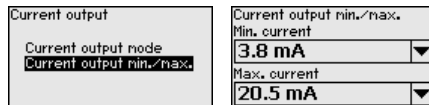

The default setting is min. current 3.8 mA and max. current 20.5 mA.

Lock/release setup - Adjustment

In the menu item "Lock/unlock adjustment", you can protect the sensor parameters against unauthorized modification. The PIN is activated/deactivated permanently.

The following adjustment functions are possible without entering the PIN:

- Select menu items and show data
- Read data from the sensor into the display and adjustment module.

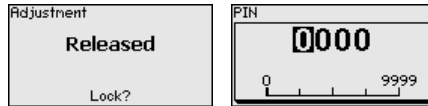

Caution:

With active PIN, adjustment via PACTware/DTM as well as other systems is also blocked.

You can change the PIN number under "Additional adjustments - PIN".

Display - Language

This menu item enables the setting of the requested national language.

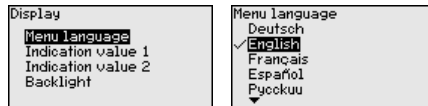

The following languages are available:

- German
- English
- French
- Spanish
- Russian
- Italian
- Dutch
- Portuguese
- Polish
- Czech
- Turkish

In the delivery status, the sensor is set to the ordered national language.

Display - Displayed value 1 and 2

In this menu item you can define the indication of the measured values on the display.

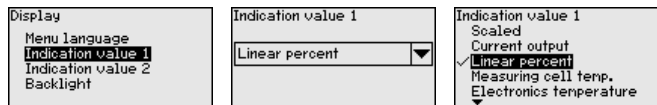

The default setting for the display value is "Lin. percent".

Display - Backlight

The display and adjustment module has a backlight for the display. In this menu item you switch on the lighting. You can find the required operating voltage in chapter "Technical data".

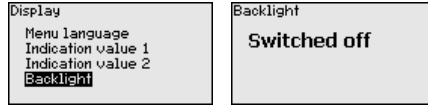

The lighting is switched off in delivery status.

Diagnostics - Device status

In this menu item, the device status is displayed.

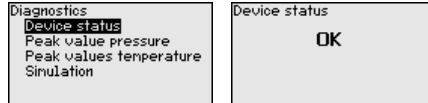

Diagnostics - Peak values, pressure

The respective min. and max. measured value is saved in the sensor. The two values are displayed in the menu item "Peak values, pressure".

In another window you can carry out a reset of the peak values separately.

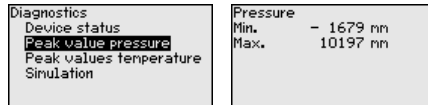

Diagnostics - Peak values, temperature

The respective min. and max. measured values of the measuring cell and electronics temperature are stored in the sensor. In the menu item "Peak value, temperature", both values are displayed.

In another window you can carry out a reset of the two peak values separately.

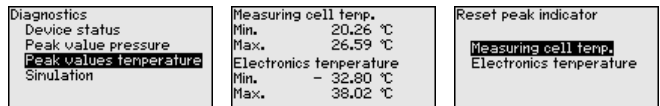

Diagnosis - Simulation

In this menu item you can simulate measured values via the current output. This allows the signal path to be tested, e.g. via downstream indicating instruments or the input card of the control system.

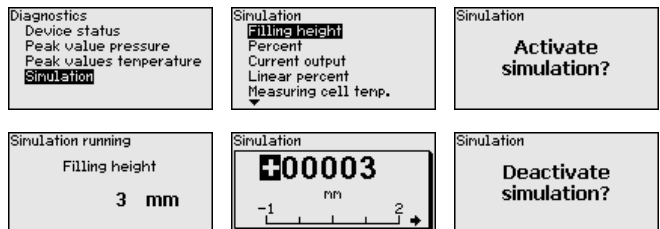

Select the requested simulation size and adjust the requested value.

**Caution:**

During simulation, the simulated value is outputted as 4 ... 20 mA current value and digital HART signal.

Push the **[ESC]** key to deactivate the simulation.

**Information:**

The simulation is terminated automatically 60 minutes after the last key has been pushed.

Additional settings - PIN

By entering a 4-digit PIN, you protect the sensor data against unauthorized access and unintentional modification.

In this menu item, the PIN is displayed or edited as well as modified. However, it is only available when the adjustment is released in the menu "Setup/ Lock/release adjustment".

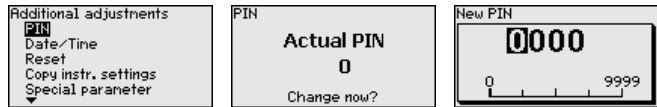

In delivery status, the PIN is "0000".

Additional adjustments - Date Time

In this menu item, you adjust the internal clock of the sensor. There is no adjustment to summer/winter time.

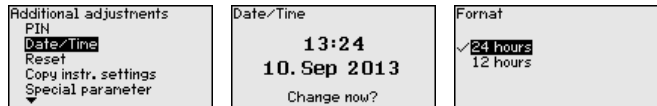
**Additional adjustments - Reset**

With a reset, certain parameter adjustments carried out by the user are reset.

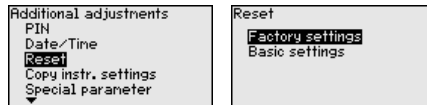

The following reset functions are available:

Delivery status: Restoring the parameter settings at the time of shipment from the factory incl. the order-specific settings. A user-programmable linearization curve as well as the measured value memory will be deleted.

Basic settings: Resetting the parameter settings incl. special parameters to the default values of the respective instrument. A programmed linearization curve as well as the measured value memory is deleted.

The following table shows the default values of the instrument. Depending on the instrument version or application, all menu items may not be available or some may be differently assigned:

Reset - Setup

Menu item	Parameter	Default value
Measurement loop name		Sensor
Application	Application process pressure Application level	No reset
	Slave for electronic differential pressure	No reset
Units	Unit of measurement	mbar (with nominal measuring range ≤400 mbar) bar (with nominal measuring ranges ≥1 bar)
	Temperature unit	°C
Position correction		0.00 bar
Adjustment	Zero/Min. adjustment	0.00 bar 0.00 %
	Span/Max. adjustment	Nominal measuring range in bar 100.00 %
Damping	Integration time	0.0 s
Current output	Current output - Mode	Output characteristics 4 ... 20 mA Reaction when malfunction occurs ≤ 3.6 mA
	Current output - Min./Max.	3.8 mA 20.5 mA
Lock adjustment		Released

Reset - Display

Menu item	Default value
Menu language	Order-specific
Displayed value 1	Current output in %
Displayed value 2	Measuring cell temperature in °C
Backlight	Switched off

Reset - Diagnosis

Menu item	Parameter	Default value
Sensor status		-
Peak value	Pressure	Actual measured value
	Temperature	Actual temperature values from measuring cell, electronics

Menu item	Parameter	Default value
Simulation		Process pressure

Reset - Additional settings

Menu item	Parameter	Default value
PIN		0000
Date/Time		Actual date/Actual time
Copy instrument settings		
Special parameters		No reset
Scaling	Scaling size	Volume in l
	Scaling format	0 % corresponds to 0 l 100 % corresponds to 0 l
Current output	Current output - Size	Lin. percent - Level
	Current output - adjustment	0 ... 100 % correspond to 4 ... 20 mA
HART mode		Address 0

Additional adjustments - Copy instrument settings

With this function the following device settings are copied.

The following parameters or settings are saved:

- All parameters of the menu "Setup" and "Display"
- The menu items "Reset, Date/Time" in the menu "Additional settings"
- Special parameters

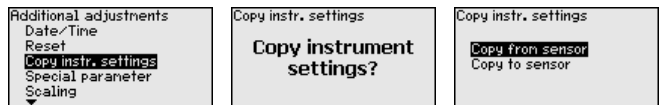

The copied data are permanently saved in the display and adjustment module. They remain even in case of voltage loss.



Note:

Before the data are stored in the sensor, they are checked to make sure they match the sensor. For this purpose, the sensor type of the source data as well as the target sensor are displayed. Storing is only carried out after release.

Additional adjustments - Special parameters

In this menu item you gain access to the protected area where you can enter special parameters. In exceptional cases, individual parameters can be modified in order to adapt the sensor to special requirements.

Change the settings of the special parameters only after having contacted our service staff.



Additional adjustments - HART mode

The sensor offers the HART modes "Analogue current output" and "Fix current (4 mA)". In this menu item you determine the HART mode and enter the address with Multidrop mode.

In the mode "Fixed current output" up to 63 sensors can be operated on one two-wire cable (Multidrop operation). An address between 0 and 63 must be assigned to each sensor.

If you select the function "Analogue current output" and also enter an address number, you can output a 4 ... 20 mA signal in Multidrop mode.

With the mode "Fixed current (4 mA)" a fixed 4 mA signal is outputted independently of the actual level.

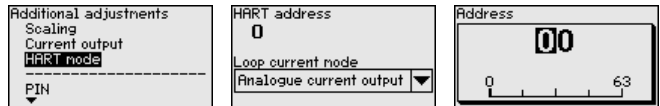

The default setting is "Analogue current output" and the address 00.

Info - Instrument name

In this menu item, you read out the instrument name and the instrument serial number:

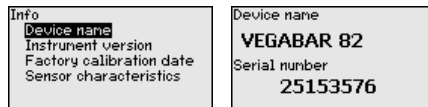

Info - Instrument version

In this menu item, the hardware and software version of the sensor is displayed.

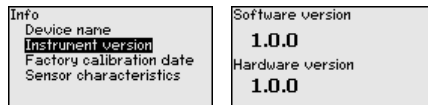

Info - Factory calibration date

In this menu item, the date of factory calibration of the sensor as well as the date of the last change of sensor parameters are displayed via the display and adjustment module or via the PC.

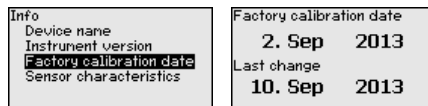

Info - Sensor characteristics

In this menu item, the features of the sensor such as approval, process fitting, seal, measuring range, electronics, housing and others are displayed.

Info Device name Instrument version Factory calibration date Sensor characteristics	Sensor characteristics Display now?
---	--

6.5 Saving the parameter adjustment data

We recommend noting the adjusted data, e.g. in this operating instructions manual, and archiving them afterwards. They are thus available for multiple use or service purposes.

If the instrument is equipped with a display and adjustment module, the data in the sensor can be saved in the display and adjustment module. The procedure is described in the operating instructions manual "*Display and adjustment module*" in the menu item "*Copy sensor data*". The data remain there permanently even if the sensor power supply fails.

The following data or settings for adjustment of the display and adjustment module are saved:

- All data of the menu "*Setup*" and "*Display*"
- In the menu "*Additional adjustments*" the items "*Sensor-specific units, temperature unit and linearization*"
- The values of the user programmable linearization curve

The function can also be used to transfer settings from one instrument to another instrument of the same type. If it is necessary to exchange a sensor, the display and adjustment module is inserted into the replacement instrument and the data are likewise written into the sensor via the menu item "*Copy sensor data*".

7 Setup with PACTware

7.1 Connect the PC

Via the interface adapter directly on the sensor

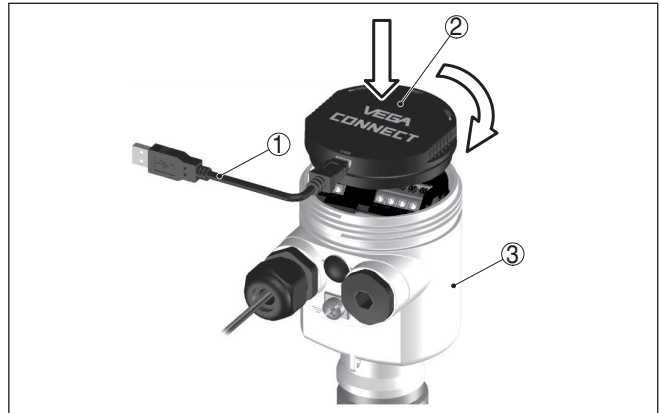

Fig. 38: Connection of the PC directly to the sensor via the interface adapter

- 1 USB cable to the PC
- 2 Interface adapter VEGACONNECT
- 3 Sensor

Via the interface adapter and HART

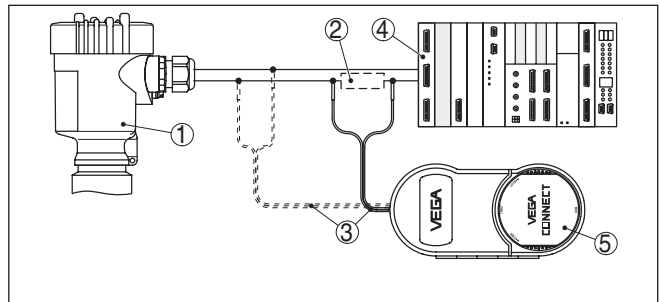

Fig. 39: Connecting the PC via HART to the signal cable

- 1 Sensor
- 2 HART resistance 250 Ω (optional depending on processing)
- 3 Connection cable with 2 mm pins and terminals
- 4 Processing system/PLC/Voltage supply
- 5 Interface adapter, for example VEGACONNECT 4



Note:

With power supply units with integrated HART resistance (internal resistance approx. 250 Ω), an additional external resistance is not necessary. This applies, e.g. to the VEGA instruments VEGATRENN 149A, VEGAMET 381, VEGAMET 391. Common Ex separators are also usually equipped with a sufficient current limitation resistance. In such cases, the interface converter can be connected parallel to the 4 ... 20 mA cable (dashed line in the previous illustration).

7.2 Parameter adjustment

Prerequisites

For parameter adjustment of the sensor via a Windows PC, the configuration software PACTware and a suitable instrument driver (DTM) according to FDT standard are required. The up-to-date PACTware version as well as all available DTMs are compiled in a DTM Collection. The DTMs can also be integrated into other frame applications according to FDT standard.



Note:

To ensure that all instrument functions are supported, you should always use the latest DTM Collection. Furthermore, not all described functions are included in older firmware versions. You can download the latest instrument software from our homepage. A description of the update procedure is also available in the Internet.

Further setup steps are described in the operating instructions manual "DTM Collection/PACTware" attached to each DTM Collection and which can also be downloaded from the Internet. Detailed descriptions are available in the online help of PACTware and the DTMs.

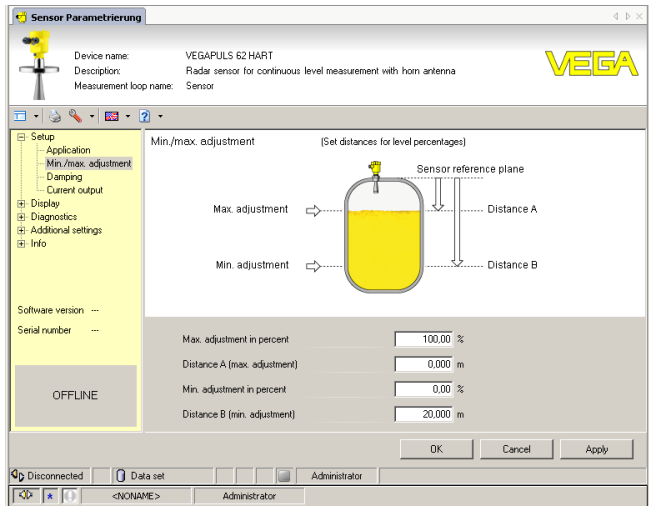

Fig. 40: Example of a DTM view

Standard/Full version

All device DTMs are available as a free-of-charge standard version and as a full version that must be purchased. In the standard version, all functions for complete setup are already included. An assistant for simple project configuration simplifies the adjustment considerably. Saving/printing the project as well as import/export functions are also part of the standard version.

In the full version there is also an extended print function for complete project documentation as well as a save function for measured value and echo curves. In addition, there is a tank calculation program as well as a multiviewer for display and analysis of the saved measured value and echo curves.

The standard version is available as a download under www.vega.com/downloads and "Software". The full version is available on CD from the agency serving you.

7.3 Saving the parameter adjustment data

We recommend documenting or saving the parameter adjustment data via PACTware. That way the data are available for multiple use or service purposes.

8 Set up with other systems

8.1 DD adjustment programs

Device descriptions as Enhanced Device Description (EDD) are available for DD adjustment programs such as, for example, AMS™ and PDM.

The files can be downloaded at www.vega.com/downloads under "Software".

8.2 Field Communicator 375, 475

Device descriptions for the instrument are available as EDD for parameter adjustment with the Field Communicator 375 or 475.

9 Diagnosis, asset management and service

9.1 Maintenance

Maintenance

If the instrument is used properly, no special maintenance is required in normal operation.

In some applications, product buildup on the diaphragm can influence the measuring result. Depending on the sensor and application, take precautions to ensure that heavy buildup, and especially a hardening thereof, is avoided.

9.2 Diagnosis memory

The instrument has several memories which are available for diagnosis purposes. The data remain even with voltage interruption.

Measured value memory

Up to 60,000 measured values can be stored in the sensor in a ring memory. Each entry contains date/time as well as the respective measured value. Storable values are for example:

- Pressure
- Differential pressure
- Level
- Flow
- Density
- Interface
- Percentage value
- Lin. percent
- Scaled values
- Measuring cell temperature
- Electronics temperature

When the instrument is shipped, the measured value memory is active, saving distance, measurement certainty and electronics temperature every minute.

The requested values and recording conditions are set via a PC with PACTware/DTM or the control system with EDD. Data are thus read out and also reset.

Event memory

Up to 500 events are automatically stored with a time stamp in the sensor (non-deletable). Each entry contains date/time, event type, event description and value. Event types are for example:

- Modification of a parameter
- Switch-on and switch-off times
- Status messages (according to NE 107)
- Error messages (according to NE 107)

The data are read out via a PC with PACTware/DTM or the control system with EDD.

9.3 Asset Management function

The instrument features self-monitoring and diagnostics according to NE 107 and VDI/VDE 2650. In addition to the status messages in

the following tables there are more detailed error messages available under the menu item "*Diagnostics*" via the display and adjustment module, PACTware/DTM and EDD.

Status messages

The status messages are divided into the following categories:

- Failure
- Function check
- Out of specification
- Maintenance requirement

and explained by pictographs:

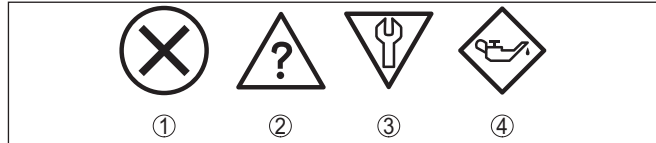

Fig. 41: Pictographs of the status messages

- 1 Failure - red
- 2 Out of specification - yellow
- 3 Function check - orange
- 4 Maintenance - blue

Failure: Due to a malfunction in the instrument, a failure message is outputted.

This status message is always active. It cannot be deactivated by the user.

Function check: The instrument is in operation, the measured value is temporarily invalid (for example during simulation).

This status message is inactive by default. It can be activated by the user via PACTware/DTM or EDD.

Out of specification: The measured value is unstable because the instrument specification is exceeded (e.g. electronics temperature).

This status message is inactive by default. It can be activated by the user via PACTware/DTM or EDD.

Maintenance: Due to external influences, the instrument function is limited. The measurement is affected, but the measured value is still valid. Plan in maintenance for the instrument because a failure is expected in the near future (e.g. due to buildup).

This status message is inactive by default. It can be activated by the user via PACTware/DTM or EDD.

Failure

The following table shows the error codes in the status message "*Failure*" and gives information on the reason and rectification. Keep in mind that some information is only valid with four-wire instruments.

Code Text message	Cause	Rectification
F013 no measured value available	– No valid measured value available	– Gauge pressure or low pressure, measuring cell defective
F017 Adjustment span too small	– Adjustment not within specification	– Change the adjustment according to the limit values
F025 Error in the linearization table	– Index markers are not continuously rising, for example unlogical value pairs	– Check linearization table – Delete table/Create new
F036 no operable sensor software	– Failed or interrupted software update	– Repeat software update – Check electronics version – Exchanging the electronics – Send instrument for repair
F040 Error in the electronics	– Hardware defect	– Exchanging the electronics – Send instrument for repair
F041 Error in the electronics	– No connection to the sensor electronics	– Check connection to the sensor electronics (with detachable version)
F080	– General software error	– Separate operating voltage briefly
F113 Communication error, display and adjustment module Adjustment software PACtware out of order	– EMC interference	– Remove EMC influences
F125 Unpermissible electronics temperature	– Temperature of the electronics in the non-specified section	– Check ambient temperature – Isolate electronics – Use instrument with higher temperature range
F260 Error in the calibration	– Error in the calibration carried out in the factory – Error in the EEPROM	– Exchanging the electronics – Send instrument for repair
F261 Error in the configuration	– Error during setup – Error when carrying out a reset	– Repeat setup – Repeat reset

Code Text message	Cause	Rectification
F265 Measurement function disturbed	– Sensor no longer carries out a measurement	– Carry out a reset – Separate operating voltage briefly
F266 Impermissible operating voltage	– Operating voltage below specified range	– Check electrical connection – if necessary, increase operating voltage

Function check

The following table shows the error codes and text messages in the status message "*Function check*" and provides information on causes as well as corrective measures.

Code Text message	Cause	Rectification
C700 Simulation active	– A simulation is active	– Finish simulation – Wait for the automatic end after 60 mins.

Out of specification

The following table shows the error codes and text messages in the status message "*Out of specification*" and provides information on causes as well as corrective measures.

Code Text message	Cause	Rectification
S600 Unpermissible electronics temperature	– Temperature of the electronics in the non-specified section	– Check ambient temperature – Isolate electronics – Use instrument with higher temperature range
S603 Impermissible operating voltage	– Operating voltage below specified range	– Check electrical connection – if necessary, increase operating voltage

Maintenance

The following table shows the error codes and text messages in the status message "*Maintenance*" and provides information on causes as well as corrective measures.

Code Text message	Cause	Rectification
M500 Error in the delivery status	– Stored delivery status is wrong	– Send instrument for repair

Code Text message	Cause	Rectification
M501 Error in the non-active linearization table	– Index markers are not continuously rising, for example unlogical value pairs	– Check linearization table – Delete table/Create new
M502 Error in the event memory	– Hardware error EEPROM	– Exchanging the electronics – Send instrument for repair
M504 Error on an device interface	– Hardware defect	– Check connections – Exchanging the electronics – Send instrument for repair
M507 Error in the instrument settings	– Error during setup – Error when carrying out a reset	– Carry out reset and repeat setup

9.4 Rectify faults

Reaction when malfunctions occur

The operator of the system is responsible for taking suitable measures to rectify faults.

Procedure for fault rectification

The first measures are:

- Evaluation of fault messages, for example via the display and adjustment module
- Checking the output signal
- Treatment of measurement errors

Further comprehensive diagnostics options offer a PC with the software PACTware and the suitable DTM. In many cases, the reasons can be determined in this way and faults can be rectified.

Check the 4 ... 20 mA signal

Connect a multimeter in the suitable measuring range according to the wiring plan. The following table describes possible errors in the current signal and helps to remove them:

Error	Cause	Rectification
4 ... 20 mA signal not stable	– Fluctuations of the measured variable	– Set damping according to the instrument via the display and adjustment module or PACTware/DTM

Error	Cause	Rectification
4 ... 20 mA signal missing	– Electrical connection faulty	– Check connection according to chapter "Connection steps" and if necessary, correct according to chapter "Wiring plan"
	– Voltage supply missing	– Check cables for breaks; repair if necessary
	– Operating voltage too low or load resistance too high	– Check, adapt if necessary
Current signal greater than 22 mA or less than 3.6 mA	– Electronics module in the sensor defective	– Exchange the instrument or send it in for repair

Reaction after fault rectification

Depending on the reason for the fault and the measures taken, the steps described in chapter "Setup" must be carried out again or must be checked for plausibility and completeness.

24 hour service hotline

Should these measures not be successful, please call in urgent cases the VEGA service hotline under the phone no. **+49 1805 858550**.

The hotline is also available outside normal working hours, seven days a week around the clock.

Since we offer this service worldwide, the support is provided in English. The service itself is free of charge, the only costs involved are the normal call charges.

9.5 Calculation of total deviation (according to DIN 16086)

Meaning of the total deviation

The total deviation of a pressure transmitter indicates the maximum measurement error to be expected in practice. It is also called maximum practical deviation or operational error.

According to DIN 16086, the total deviation F_{total} is the sum of the basic accuracy F_{perf} and the long-term stability F_{stab} :

$$F_{\text{total}} = F_{\text{perf}} + F_{\text{stab}}$$

The basic accuracy F_{perf} is composed of the deviation F_{KI} and the thermal change of zero signal and output span F_{T} :

$$F_{\text{perf}} = \sqrt{((F_{\text{T}})^2 + (F_{\text{KI}})^2)}$$

This applies to the digital signal output via HART, Profibus PA or Foundation Fieldbus. With a 4 ... 20 mA output, there is also the thermal change of the current output F_{a} :

$$F_{\text{perf}} = \sqrt{((F_{\text{T}})^2 + (F_{\text{KI}})^2 + (F_{\text{a}})^2)}$$

To provide a better overview, the formula symbols are listed together below:

- F_{total} : Total deviation
- F_{perf} : Basic accuracy
- F_{stab} : Long-term drift

- F_T : Thermal change of zero signal and output span
- F_{KI} : Deviation
- F_a : Thermal change of the current output

You can find the specifications in chapter "Technical data".

Practical example

Pressure measurement in the pipeline 8 bar (800 KPa)

Product temperature up to 50 °C

VEGABAR 83 with measuring range 10 bar, deviation < 0.075 %

Calculation of the turn down: TD = 10 bar/8 bar, TD = 1.25

Calculation - Digital output signal

1. step: Calculation of the basic accuracy

$$F_{\text{perf}} = \sqrt{((F_T)^2 + (F_{KI})^2)}$$

$$F_T = (0.15 \%) \times (0.5 + 0.5 \times \text{TD})$$

$$F_{KI} = 0.075 \%$$

$$F_{\text{perf}} = \sqrt{((0.15 \%) \times (0.5 + 0.5 \times \text{TD}))^2 + (0.075 \%)^2}$$

$$F_{\text{perf}} = 0.19 \%$$

Step 2: Calculation of the total deviation

$$F_{\text{total}} = F_{\text{perf}} + F_{\text{stab}}$$

$$F_{\text{stab}} = (0.05 \% \times \text{TD})$$

$$F_{\text{stab}} = (0.05 \% \times 1.25)$$

$$F_{\text{stab}} = 0.06 \%$$

$$F_{\text{total}} = 0.19 \% + 0.063 \% = 0.25 \%$$

Calculation - Analogue output signal

1. step: Calculation of the basic accuracy

$$F_{\text{perf}} = \sqrt{((F_T)^2 + (F_{KI})^2 + (F_a)^2)}$$

$$F_T = (0.15 \%) \times (0.5 + 0.5 \times \text{TD})$$

$$F_{KI} = 0.075 \%$$

$$F_a = 0.15 \%$$

$$F_{\text{perf}} = \sqrt{((0.15 \%) \times (0.5 + 0.5 \times \text{TD}))^2 + (0.075 \%)^2 + (0.15 \%)^2}$$

$$F_{\text{perf}} = 0.24 \%$$

Step 2: Calculation of the total deviation

$$F_{\text{total}} = F_{\text{perf}} + F_{\text{stab}}$$

$$F_{\text{stab}} = (0.05 \% \times \text{TD})$$

$$F_{\text{stab}} = (0.05 \% \times 1.25)$$

$$F_{\text{stab}} = 0.06 \%$$

$$F_{\text{total}} = 0.24 \% + 0.06 \% = 0.30 \%$$

9.6 Exchange process assembly with version IP 68 (25 bar)

With version IP 68 (25 bar), the user can exchange the process assembly on site. Connection cable and external housing can be kept.

Required tools:

- Hexagon socket wrench, size 2

**Caution:**

The exchange may only be carried out in the complete absence of line voltage.



In Ex applications, only a replacement part with appropriate Ex approval may be used.

Proceed as follows when carrying out the exchange:

1. Loosen the fixing screw with the hexagon socket wrench
2. Carefully detach the cable assembly from the process assembly

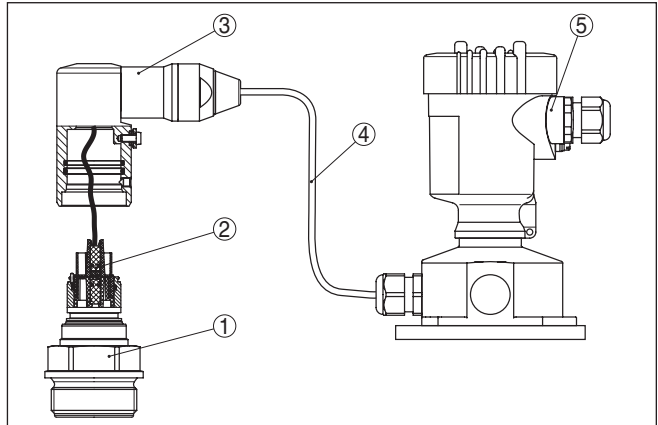

Fig. 42: VEGABAR 83 in IP 68 version, 25 bar and lateral cable outlet, external housing

- 1 Process assembly
- 2 Plug connector
- 3 Cable assembly
- 4 Connection cable
- 5 External housing

3. Loosen the plug connector
4. Mount the new process assembly on the measuring point
5. Plug the connector back in
6. Mount the cable assembly on the process assembly and turn it to the desired position
7. Tighten the fixing screw with the hexagon socket wrench

The exchange is finished.

If there is no replacement part available on site, one can be ordered from the agency serving you.

The necessary serial number can be found on the type label of the instrument or on the delivery note.

9.7 Exchanging the electronics module

In case of a defect, the user can replace the electronics module with another one of identical type.



In Ex applications, only instruments and electronics modules with appropriate Ex approval may be used.

If there is no electronics module available on site, one can be ordered from the agency serving you.

Ordering and exchange are possible **with** or **without** sensor serial number. The electronics module **with** serial number includes **order-specific** data such as factory setting, seal material etc. These are not included in the electronics module **without** serial number.

The serial number is stated on the type label of VEGABAR 83 or on the delivery note.

You can find detailed information on the electronics exchange in the booklet "*Operating instructions for electronics module VEGABAR series 80*".

9.8 Software update

The following components are required to update the sensor software:

- Sensor
- Voltage supply
- Interface adapter VEGACONNECT
- PC with PACTware
- Current sensor software as file

You can find the actual sensor software as well as detailed information of the procedure under "www.vega.com/downloads" and "*Software*".

You can find information about the installation in the download file.



Caution:

Instruments with approvals can be bound to certain software versions. Therefore make sure that the approval remains effective with a software update.

You can find detailed information on www.vega.com/downloads and "*Approvals*".

9.9 How to proceed in case of repair

You can find a repair form as well as detailed information on how to proceed under www.vega.com/downloads and "*Forms and certificates*".

By doing this you help us carry out the repair quickly and without having to call back for needed information.

If a repair is necessary, please proceed as follows:

- Print and fill out one form per instrument
- Clean the instrument and pack it damage-proof
- Attach the completed form and, if need be, also a safety data sheet outside on the packaging
- Please contact the agency serving you to get the address for the return shipment. You can find the agency on our home page www.vega.com.

10 Dismounting

10.1 Dismounting steps

**Warning:**

Before dismounting, be aware of dangerous process conditions such as e.g. pressure in the vessel or pipeline, high temperatures, corrosive or toxic products etc.

Take note of chapters "*Mounting*" and "*Connecting to power supply*" and carry out the listed steps in reverse order.

10.2 Disposal

The instrument consists of materials which can be recycled by specialised recycling companies. We use recyclable materials and have designed the parts to be easily separable.

Correct disposal avoids negative effects on humans and the environment and ensures recycling of useful raw materials.

Materials: see chapter "*Technical data*"

If you have no way to dispose of the old instrument properly, please contact us concerning return and disposal.

WEEE directive 2002/96/EG

This instrument is not subject to the WEEE directive 2002/96/EG and the respective national laws. Pass the instrument directly on to a specialised recycling company and do not use the municipal collecting points. These may be used only for privately used products according to the WEEE directive.

11 Supplement

11.1 Technical data

Materials and weights

Materials, wetted (piezoresistive/strain gauge measuring cell)

Process fitting	316L
Diaphragm standard	316L
Diaphragm from measuring range 25 bar, Elgiloy 2.4711 with not flush version	
Seal ring, O-ring	FKM (VP2/A), EPDM (A+P 75.5/KW75F), FFKM (Perlast G75S), FEPM (Fluoraz SD890)
Seal process fitting thread G½ (EN 837)	Klingersil C-4400

Materials, wetted (METEC® measuring cell)

Process fitting	316L
Diaphragm	Alloy C-276, gold-coated 20 µ, gold/rhodium-coated 5 µ/1 µ
Seal process fitting, thread G1½ (DIN 3852-A)	Klingersil C-4400
M44 x 1.25 (DIN 13)	FKM, FFKM, EPDM

Materials for applications in foodstuffs

Surface quality hygienic fittings, typ.	R _a < 0.8 µm
---	-------------------------

Materials, non-wetted parts

Type label support on connection cable	PE hard
Isolating liquid METEC® measuring cell	KN 92 med. white oil, FDA conform
Internal transmission liquid piezoresistive/strain gauge measuring cell	Synthetic oil, Halocarbon oil ¹⁾²⁾
Electronics housing	Plastic PBT (polyester), Alu die-casting powder-coated, 316L
External housing	plastic PBT (Polyester), 316L
Socket, wall mounting plate external housing	plastic PBT (Polyester), 316L
Seal between base and wall mounting plate	EPDM (fixed connected)
Seal ring, housing cover	NBR (stainless steel housing), silicone (Alu/plastic housing)
Inspection window in housing cover for display and adjustment module	Polycarbonate (UL-746-C listed)
Ground terminal	316Ti/316L
Connection cable with IP 68 1 bar version	PE

¹⁾ Synthetic oil for measuring ranges up to 16 bar, FDA listed for the food processing industry. For measuring ranges up to 25 bar dry measuring cell.

²⁾ Halocarbon oil: Generally in oxygen applications, not with vacuum measuring ranges, not with absolute measuring ranges < 1 bar_{abs}.

Connection cable, master and slave sensor PE, PUR

Weights

Total weight VEGABAR 83 approx. 0.8 ... 8 kg (1.764 ... 17.64 lbs), depending on process fitting and housing

Input variable - Piezoresistive/Thin film measuring cell

Adjustment

Adjustment range of the min./max. adjustment relating to the nominal measuring range:

- Percentage value -10 ... 110 %
- Pressure value -20 ... 120 %

Adjustment range of the zero/span adjustment relating to the nominal measuring range:

- zero -20 ... +95 %
- span -120 ... +120 %³⁾
- Difference between zero and span max. 120 % of the nominal range

Recommended max. turn down 20 : 1 (no limitation)

Nominal measuring ranges and overload capability in bar/kPa

The specifications are only an overview and refer to the measuring cell. Limitations due to the material and version of the process fitting as well as the selected pressure type are possible. The specifications on the nameplate apply.

Nominal range	Overload capacity, max. pressure	Overload capacity, min. pressure
Gauge pressure		
0 ... +0.4 bar/0 ... +40 kPa	+2 bar/+200 kPa	-1 bar/-100 kPa
0 ... +1 bar/0 ... +100 kPa	+5 bar/+500 kPa	-1 bar/-100 kPa
0 ... +2.5 bar/0 ... +250 kPa	+10 bar/+1000 kPa	-1 bar/-100 kPa
0 ... +10 bar/0 ... +1000 kPa	+35 bar/+3500 kPa	-1 bar/-100 kPa
0 ... +25 bar/0 ... +2500 kPa	+50 bar/+5000 kPa	-1 bar/-100 kPa
0 ... +40 bar/0 ... +4000 kPa	+80 bar/+8000 kPa	-1 bar/-100 kPa
0 ... +100 bar/0 ... +10 MPa	+200 bar/+20 MPa	-1 bar/-100 kPa
0 ... +250 bar/0 ... +25 MPa	+500 bar/+50 MPa	-1 bar/-100 kPa
0 ... +600 bar/0 ... +60 kPa	+1200 bar/+120 MPa	-1 bar/-100 kPa
0 ... +1000 bar/0 ... +100 MPa	+1500 bar/+150 MPa	-1 bar/-100 kPa
-1 ... 0 bar/-100 ... 0 kPa	+5 bar/+500 kPa	-1 bar/-100 kPa
-1 ... +1.5 bar/-100 ... +150 kPa	+10 bar/+1000 kPa	-1 bar/-100 kPa
-1 ... +10 bar/-100 ... +1000 kPa	+80 bar/+8000 kPa	-1 bar/-100 kPa
-1 ... +25 bar/-100 ... +2500 kPa	+80 bar/+8000 kPa	-1 bar/-100 kPa
-1 ... +40 bar/-100 ... +4000 kPa	+80 bar/+8000 kPa	-1 bar/-100 kPa
-0.2 ... +0.2 bar/-20 ... +20 kPa	+2 bar/+200 kPa	-1 bar/-100 kPa
-0.5 ... +0.5 bar/-50 ... +50 kPa	+5 bar/+500 kPa	-1 bar/-100 kPa

³⁾ Values less than -1 bar cannot be set.

Nominal range	Overload capacity, max. pressure	Overload capacity, min. pressure
Absolute pressure		
0 ... 1 bar/0 ... 100 kPa	5 bar/+500 kPa	0 bar abs.
0 ... 2.5 bar/0 ... 250 kPa	10 bar/+1000 kPa	0 bar abs.
0 ... 10 bar/0 ... 1000 kPa	35 bar/+3500 kPa	0 bar abs.
0 ... 25 bar/0 ... 2500 kPa	50 bar/+5000 kPa	0 bar abs.
0 ... 40 bar/0 ... 4000 kPa	80 bar/8000 kPa	0 bar abs.

Nominal measuring ranges and overload capacity in psi

The specifications are only an overview and refer to the measuring cell. Limitations due to the material and version of the process fitting as well as the selected pressure type are possible. The specifications on the nameplate apply.

Nominal range	Overload capacity, max. pressure	Overload capacity, min. pressure
Gauge pressure		
0 ... +5 psig	+25 psig	-14.5 psig
0 ... +15 psig	+75 psig	-14.5 psig
0 ... +30 psig	+120 psig	-14.5 psig
0 ... +150 psig	+450 psig	-14.5 psig
0 ... +300 psig	+600 psig	-14.5 psig
0 ... +600 psig	+1200 psig	-14.5 psig
0 ... +1500 psig	+3000 psig	-14.5 psig
0 ... +3000 psig	+6000 psig	-14.5 psig
0 ... +9000 psig	+18000 psig	-14.5 psig
0 ... +15000 psig	+22500 psig	-14.5 psig
-14.5 ... 0 psig	+75 psig	-14.5 psig
-14.5 ... +20 psig	+120 psig	-14.5 psig
-14.5 ... +150 psig	+1200 psig	-14.5 psig
-14.5 ... +300 psig	+1200 psig	-14.5 psig
-14.5 ... +600 psig	+1200 psig	-14.5 psig
-3 ... +3 psig	+25 psig	-14.5 psig
-7 ... +7 psig	+75 psig	-14.5 psig
Absolute pressure		
0 ... +15 psi	+75 psi	0 psi
0 ... +30 psi	+120 psi	0 psi
0 ... +150 psi	+1200 psi	0 psi
0 ... +300 psi	+1200 psi	0 psi

Input variable - Ceramic/metal measuring cell

Adjustment

Adjustment range of the min./max. adjustment relating to the nominal measuring range:

- Percentage value -10 ... 110 %
- Pressure value -20 ... 120 %

Adjustment range of the zero/span adjustment relating to the nominal measuring range:

- zero -20 ... +95 %
- span -120 ... +120 %⁴⁾
- Difference between zero and span max. 120 % of the nominal range

Recommended max. turn down 20 : 1 (no limitation)

Nominal measuring ranges and overload capability in bar/kPa

The specifications are only an overview and refer to the measuring cell. Limitations due to the material and version of the process fitting are possible. The specifications on the nameplate apply.

Nominal range	Overload capacity, max. pressure	Overload capacity, min. pressure
Gauge pressure		
0 ... +0.1 bar/0 ... +10 kPa	+15 bar/+1500 kPa	-1 bar/-100 kPa
0 ... +0.4 bar/0 ... +40 kPa	+30 bar/+3000 kPa	-1 bar/-100 kPa
0 ... +1 bar/0 ... +100 kPa	+35 bar/+3500 kPa	-1 bar/-100 kPa
0 ... +2.5 bar/0 ... +250 kPa	+50 bar/+5000 kPa	-1 bar/-100 kPa
0 ... +10 bar/0 ... +1000 kPa	+90 bar/+9000 kPa	-1 bar/-100 kPa
0 ... +25 bar/0 ... +2500 kPa	+130 bar/+13000 kPa	-1 bar/-100 kPa
-1 ... 0 bar/-100 ... 0 kPa	+35 bar/+3500 kPa	-1 bar/-100 kPa
-1 ... +1.5 bar/-100 ... +150 kPa	+40 bar/+4000 kPa	-1 bar/-100 kPa
-1 ... +10 bar/-100 ... +1000 kPa	+90 bar/+9000 kPa	-1 bar/-100 kPa
-1 ... +25 bar/-100 ... +2500 kPa	+130 bar/+13000 kPa	-1 bar/-100 kPa
-0.05 ... +0.05 bar/-5 ... +5 kPa	+15 bar/+1500 kPa	-0.2 bar/-20 kPa
-0.2 ... +0.2 bar/-20 ... +20 kPa	+20 bar/+2000 kPa	-0.4 bar/-40 kPa
-0.5 ... +0.5 bar/-50 ... +50 kPa	+35 bar/+3500 kPa	-1 bar/-100 kPa
Absolute pressure		
0 ... 0.1 bar/0 ... 10 kPa	15 bar/1500 kPa	0 bar abs.
0 ... 0.4 bar/0 ... 40 kPa	30 bar/3000 kPa	0 bar abs.
0 ... 1 bar/0 ... 100 kPa	35 bar/3500 kPa	0 bar abs.
0 ... 2.5 bar/0 ... 250 kPa	50 bar/5000 kPa	0 bar abs.
0 ... 10 bar/0 ... 1000 kPa	90 bar/9000 kPa	0 bar abs.
0 ... 25 bar/0 ... 2500 kPa	130 bar/13000 kPa	0 bar abs.

Nominal measuring ranges and overload capacity in psi

The specifications are only an overview and refer to the measuring cell. Limitations due to the material and version of the process fitting are possible. The specifications on the nameplate apply.

⁴⁾ Values less than -1 bar cannot be set.

Nominal range	Overload capacity, max. pressure	Overload capacity, min. pressure
Gauge pressure		
0 ... +0.15 psig	+225 psig	
0 ... +5 psig	+375 psig	-11.60 psig
0 ... +15 psig	+525 psig	-14.5 psig
0 ... +30 psig	+600 psig	-14.5 psig
0 ... +150 psig	+1350 psig	-14.5 psig
0 ... +300 psig	+1500 psig	-14.5 psig
-14.5 ... 0 psig	+500 psig	-14.5 psig
-14.5 ... +20 psig	+580 psig	-14.5 psig
-14.5 ... +150 psig	+1480 psig	-14.5 psig
-14.5 ... +300 psig	+1575 psig	-14.5 psig
-0.7 ... +0.7 psig	+225 psig	-14.5 psig
-3 ... +3 psig	+290 psi	-14.5 psig
-7 ... +7 psig	+510 psig	-14.5 psig
Absolute pressure		
0 ... 1.5 psi	225 psi	0 psi
0 ... 5 psi	435 psi	0 psi
0 ... 15 psi	510 psi	0 psi
0 ... 30 psi	725 psi	0 psi
0 ... 150 psi	1300 psi	0 psi
0 ... 300 psi	1900 psi	0 psi

Output variable

For details on the operating voltage see chapter "Voltage supply"

Output signal	4 ... 20 mA/HART
Range of the output signal	3.8 ... 20.5 mA/HART (default setting)
Fulfilled HART specification	7.3
Signal resolution	0.3 μ A
Failure signal current output (adjustable)	≥ 21 mA, ≤ 3.6 mA, last valid measured value
Max. output current	21.5 mA
Starting current	≤ 10 mA for 5 ms after switching on, ≤ 3.6 mA
Load	Load resistor, see chapter "Voltage supply"
Damping (63 % of the input variable), adjustable	0 ... 999 s

HART output values according to HART 7 (default setting)⁵⁾

- First HART value (PV) Linear percentage value
- Second HART value (SV) Physical unit of the application

⁵⁾ The output values can be assigned individually

- Third HART value (TV)	Measuring cell temperature
- Fourth HART value (QV)	Electronics temperature

Output variable - Second current output

For details on the operating voltage see chapter "Voltage supply"

Output signal	4 ... 20 mA (passive)
Range of the output signal	3.8 ... 20.5 mA (default setting)
Signal resolution	0.3 μ A
Failure signal current output (adjustable)	Last valid measured value, ≥ 21 mA, ≤ 3.6 mA
Max. output current	21.5 mA
Starting current	≤ 10 mA for 5 ms after switching on, ≤ 3.6 mA
Load	Load resistor, see chapter "Voltage supply"
Damping (63 % of the input variable), adjustable	0 ... 999 s

Dynamic behaviour output

Run-up time approx. 10 s

Dynamic characteristics, depending on medium, temperature and, if applicable, chemical seal

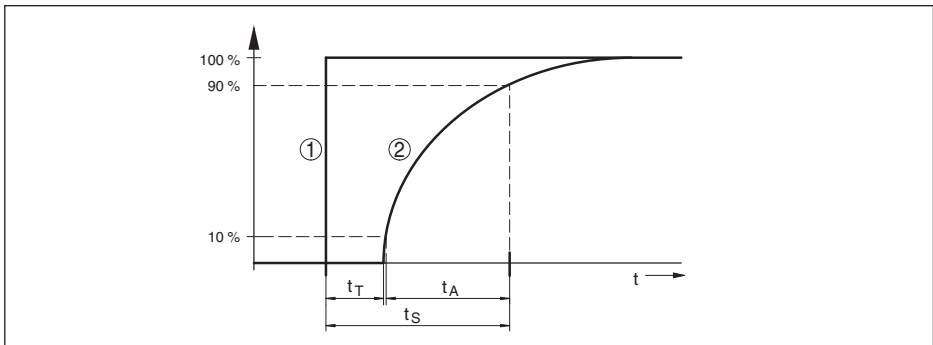

Fig. 43: Behaviour in case of sudden change of the process variable. t_T : dead time; t_A : rise time; t_S : jump response time

- 1 Process variable
- 2 Output signal

Dead time	> 45 ms
Rise time	> 35 ms (10 ... 90 %)
Step response time	> 80 ms (t_i : 0 s, 10 ... 90 %)
Damping (63 % of the input variable)	0 ... 999 s, adjustable

Reference conditions and actuating variables (according to DIN EN 60770-1)

Reference conditions according to DIN EN 61298-1

- Temperature	+18 ... +30 °C (+64 ... +86 °F)
- Relative humidity	45 ... 75 %

- Air pressure	860 ... 1060 mbar/86 ... 106 kPa (12.5 ... 15.4 psi)
Determination of characteristics	Limit point adjustment according to IEC 61298-2
Characteristic curve	Linear
Reference installation position	upright, diaphragm points downward
Influence of the installation position	
- Piezoresistive/strain gauge measuring cell	depending on the process fitting and the chemical seal
- METEC® measuring cell	< 5 mbar/0.5 kPa (0.07 psig)

Deviation (according to IEC 60770)

Applies to the **digital** signal output (HART, Profibus PA, Foundation Fieldbus) as well as to the **analogue** current output 4 ... 20 mA and refers to the set span. Turn down (TD) is the ratio nominal measuring range/set span.

The deviation corresponds to the value F_{ki} in chapter "Calculation of the total deviation". The value results out of the accuracy class and the respective turn down.

Accuracy class	Non-linearity, hysteresis and repeatability with TD 1 : 1 up to 5 : 1	Non-linearity, hysteresis and repeatability with 5 : 1
0.075 %	< 0.075 %	< 0.015 % x TD
0.1 %	< 0.1 %	< 0.02 % x TD
0.2 %	< 0.2 %	< 0.04 % x TD

Influence of the product or ambient temperature

Thermal change zero signal and output span

Applies to the **digital** signal output (HART, Profibus PA, Foundation Fieldbus) as well as to the **analogue** current output 4 ... 20 mA and refers to the set span. Turn down (TD) is the ratio nominal measuring range/set span.

The thermal change of zero signal and output span corresponds to the value F_T in chapter "Calculation of the total deviation (according to DIN 16086)".

Piezoresistive/strain gauge measuring cell

Turn down	In the compensated temperature range 10 ... +70 °C (+50 ... +158 °F)	Outside the compensated temperature range
TD 1 : 1	< 0.05 %/10 K	typ. < 0.05 %/10 K
TD 1 : 1 up to 5 : 1	< 0.1 %/10 K	-
TD up to 10 : 1	< 0.15 %/10 K	-

Ceramic/Metal measuring cell - Standard

Medium or ambient temperature T	Accuracy class 0.1 %	Accuracy class 0.2 %
-40 ... 0 °C (-40 ... +32 °F)	< {0.15 % + 0.015 %/K x (T)} x {0.5+0.5 x TD}	< {0.1 % + 0.03 %/K x (T)} x {0.5+0.5 x TD}
0 ... 40 °C (+32 ... +104 °F)	< {0.0075 %/K x (T - 20 °C)} x {0.5+0.5 x TD}	< {0.005 %/K x (T - 20 °C)} x {0.5+0.5 x TD}

45034-EN-131010

Medium or ambient temperature T	Accuracy class 0.1 %	Accuracy class 0.2 %
40 ... 100 °C (+104 ... +212 °F)	$< \{0.15 \% \} \times \{0.5+0.5 \times \text{TD}\}$	$< \{0.005 \%/\text{K} \times (\text{T} - 20 \text{ °C})\} \times \{0.5+0.5 \times \text{TD}\}$
100 ... 120 °C (+212 ... +248 °F)	$< \{0.15 \% + 0.005 \%/\text{K} \times (\text{T} - 100 \text{ °C})\} \times \{0.5+0.5 \times \text{TD}\}$	$< \{0.40 \% + 0.01 \%/\text{K} \times (\text{T} - 100 \text{ °C})\} \times \{0.5+0.5 \times \text{TD}\}$

Ceramic/Metal measuring cell - climate-compensated

Compensated temperature range 0 ... +100 °C (+32 ... +212 °F)

Non-compensated temperature range -40 ... 0 °C (-40 ... +32 °F), -100 ... 130 °C (212 ... +276 °F)

Nominal measuring range in bar/kPa	Nominal measuring range in psig	In the compensated temperature range	In the non-compensated temperature range
0 ... 10 bar/0 ... 1000 kPa	0 ... 150 psig	$< \{0.05 \% + 0.1 \times (0.5+0.5 \times \text{TD})\}$	$< \{0.1 \% + 0.15 \times (0.5+0.5 \times \text{TD})\}$
0 ... 25 bar/0 ... 2500 kPa	0 ... 350 psig		
-1 ... 0 bar/-100 ... 0 kPa	-15 ... 0 psig		
-1 ... 1.5 bar/-100 ... 150 kPa	-15 ... 25 psig		
-1 ... 10 bar/-100 ... 1000 kPa	-15 ... 150 psig		
-1 ... 25 bar/-100 ... 2500 kPa	-15 ... 350 psig		
0 ... 1 bar/0 ... 100 kPa	0 ... 15 psig	$< \{0.1 \% + 0.2 \times (0.5+0.5 \times \text{TD})\}$	$< \{0.1 \% + 0.3 \times (0.5+0.5 \times \text{TD})\}$
0 ... 2.5 bar/0 ... 250 kPa	0 ... 35 psig		
-0.5 ... 0.5 bar/-50 ... 50 kPa	-7 ... 7 psig		
-0.2 ... 0.2 bar/-20 ... 20 kPa	-3 ... 3 psig		
0 ... 0.4 bar/0 ... 40 kPa	0 ... 6 psig		

Thermal change, current output

Applies also to the **analogue 4 ... 20 mA** current output and refers to the set span.

Thermal change, current output $< 0.05 \% / 10 \text{ K}$, max. $< 0.15 \%$, each with -40 ... +80 °C (-40 ... +176 °F)

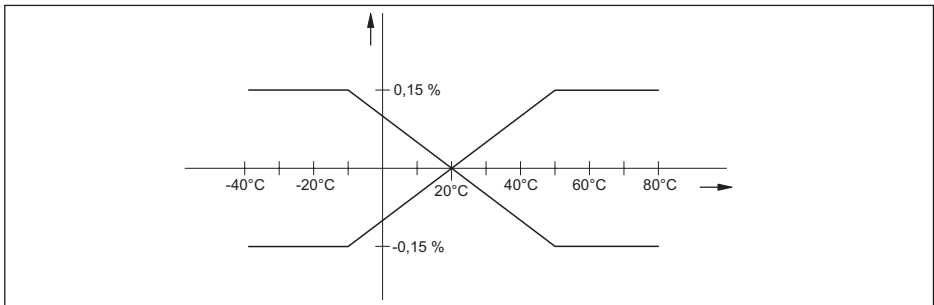

Fig. 44: Thermal change, current output

Long-term stability (according to DIN 16086 and IEC 60770-1)

Applies to **digital** HART interface as well as to **analogue** current output 4 ... 20 mA under reference conditions. Specifications refer to the set span. Turn down (TD) is the ratio nominal measuring range/set span.

	Ceramic/metal measuring cell	Piezoresistive/strain gauge measuring cell
One year	< 0.05 % x TD	< 0.1 % x TD
Five years	< 0.1 % x TD	
Ten years	< 0.2 % x TD	

Ambient conditions

Version	Ambient temperature	Storage and transport temperature
Standard version	-40 ... +80 °C (-40 ... +176 °F)	-60 ... +80 °C (-76 ... +176 °F)
Version IP 66/IP 68 (1 bar)	-20 ... +80 °C (-4 ... +176 °F)	-20 ... +80 °C (-4 ... +176 °F)
Version IP 68 (25 bar) with connection cable PUR	-20 ... +80 °C (-4 ... +176 °F)	-20 ... +80 °C (-4 ... +176 °F)
Version IP 68 (25 bar), connection cable PE	-20 ... +60 °C (-4 ... +140 °F)	-20 ... +60 °C (-4 ... +140 °F)

Process conditions

Product temperature piezoresistive/strain gauge measuring cell

Seal	Standard	Extended temperature range	Version for oxygen applications
Without sealing (with process fitting according to EN 837)	-40 ... +105 °C (-40 ... +221 °F)	-	-40 ... +60 °C (-40 ... +140 °F)
FKM (VP2/A)	-20 ... +105 °C (-4 ... +221 °F)	-20 ... +150 °C (-4 ... +302 °F)	-20 ... +60 °C (+4 ... +140 °F)
EPDM(A+P 75,5/KW75F)	-30 ... +105 °C (-22 ... +221 °F)	-30 ... +150 °C (-22 ... +302 °F)	-30 ... +60 °C (-22 ... +140 °F)
FFKM (Perlast G75S)	-15 ... +105 °C (+5 ... +221 °F)	-15 ... +150 °C (+5 ... +302 °F)	-15 ... +60 °C (+5 ... +140 °F)
FEPM (Fluoraz SD890)	-5 ... +105 °C (+23 ... +221 °F)	-	-5 ... +60 °C (+23 ... +140 °F)

Product temperature METEC® measuring cell

Version	Temperature range
Standard	-12 ... +150 °C (+10 ... +284 °F)
High temperature	-12 ... +180 °C (+10 ... +356 °F)
High temperature, screen sheet	-12 ... +200 °C (+10 ... +392 °F)

Mechanical stress, depending on the instrument version

Vibration resistance	4 g at 5 ... 200 Hz according to EN 60068-2-6 (vibration with resonance)
Shock resistance	100 g, 6 ms according to EN 60068-2-27 (mechanical shock)

Electromechanical data - version IP 66/IP 67 and IP 66/IP 68; 0.2 bar

Options of the cable entry

– Cable gland	M20 x 1.5
– Cable diameter (options)	5 ... 9 mm (0.20 ... 0.35 in) 6 ... 12 mm (0.24 ... 0.47 in) 10 ... 14 mm (0.39 ... 0.55 in)
– Cable entry	½ NPT
– Blind plug	M20 x 1.5; ½ NPT
– Closing cap	M20 x 1.5; ½ NPT
Plug options	
– Signal circuit	Plug M12 x 1, according to ISO 4400, Harting HAN, 7/8" FF
– Indication circuit	M12 x 1 plug

Wire cross-section (spring-loaded terminals)

– Massive wire, cord	0.2 ... 2.5 mm ² (AWG 24 ... 14)
– Stranded wire with end sleeve	0.2 ... 1.5 mm ² (AWG 24 ... 16)

Electromechanical data - version IP 66/IP 68 (1 bar)

Connection cable

– Configuration	four wires, one breather capillary, one suspension cable, screen braiding, metal foil, mantle
– Wire cross-section	0.5 mm ² (AWG 20)
– Wire resistance	< 0.036 Ω/m
– Tensile strength	< 1200 N (270 lbf)
– Standard length	5 m (16.4 ft)
– Max. length	180 m (590.6 ft)
– Min. bending radius	25 mm (0.984 in) with 25 °C (77 °F)
– Diameter approx.	8 mm (0.315 in)
– Colour - Non-Ex version	Black
– Colour - Ex-version	Blue

Electromechanical data - version IP 68 (25 bar)

Connection cable between IP 68 instrument and external housing

– Configuration	four wires, one suspension wire, one breather capillary, screen braiding, metal foil, mantle
– Wire cross-section	0.5 mm ² (AWG 20)
– Wire resistance	< 0.036 Ω/m (0.011 Ω/ft)
– Standard length	5 m (16.40 ft)

- Max. length 180 m (590.5 ft)
- Min. bending radius at 25 °C/77 °F 25 mm (0.985 in)
- Diameter approx. 8 mm (0.315 in)
- Colour Blue

Cable entry/plug⁶⁾

- External housing
 - 1 x cable gland M20 x 1.5 (cable: ø 5 ... 9 mm), 1 x blind plug M20 x 1.5
 - or:
 - 1x plug (depending on the version), 1x blind stopper M20x1.5

Spring-loaded terminals for wire cross-section up to 2.5 mm² (AWG 14)

Display and adjustment module

Display element Display with backlight

Measured value indication

- Number of digits 5
- Size of digits W x H = 7 x 13 mm

Adjustment elements 4 keys

Protection rating

- unassembled IP 20
- mounted into the housing without cover IP 40

Materials

- Housing ABS
- Inspection window Polyester foil

Interface to the external display and adjustment unit

Data transmission digital (I²C-Bus)

Configuration, connection cable 4-wire, screened

Cable length max.

- Sensors with signal output 4 ... 20 mA, 4 ... 20 mA/HART 50 m
- Sensors with signal output Profibus PA, Foundation Fieldbus 25 m

Interface to the slave sensor

Data transmission digital (I²C-Bus)

Configuration, connection cable 4-wire, screened

Cable length max. 25 m

Integrated clock

Date format Day.Month.Year

⁶⁾ Depending on the version M12 x 1, according to ISO 4400, Harting, 7/8" FF.

Time format	12 h/24 h
Time zone Ex factory	CET
Rate deviation max.	10.5 min/year

Measurement electronics temperature

Resolution	1 °C (1.8 °F)
Accuracy	±1 °C (1.8 °F)

Voltage supply

Operating voltage U_B	
- Non-Ex instrument	9.6 ... 35 V DC
- Ex-d instrument	9.6 ... 35 V DC
- Ex-ia instrument	9.6 ... 30 V DC
- Ex-d-ia instrument	15 ... 35 V DC
- Ex-d-ia instrument with ship approval	15 ... 35 V DC
Interpolation protection	Integrated
Permissible residual ripple - Non-Ex, Ex-ia instrument	
- for U_N 12 V DC ($9.6 \text{ V} < U_B < 14 \text{ V}$)	$\leq 0.7 V_{\text{eff}}$ (16 ... 400 Hz)
- for U_N 24 V DC ($18 \text{ V} < U_B < 35 \text{ V}$)	$\leq 1.0 V_{\text{eff}}$ (16 ... 400 Hz)
Permissible residual ripple - Ex-d-ia instrument	
- for U_N 24 V DC ($18 \text{ V} < U_B < 35 \text{ V}$)	$\leq 1 V_{\text{eff}}$ (16 ... 400 Hz)
Load resistor	
- Calculation	$(U_B - U_{\text{min}})/0.022 \text{ A}$
- Example - Non-Ex instrument with $U_B = 24 \text{ V DC}$	$(24 \text{ V} - 9.6 \text{ V})/0.022 \text{ A} = 655 \Omega$

Potential connections in the instrument

Electronics	Not non-floating
Ground terminal	Galvanically connected with the process fitting

Electrical protective measures

Housing material	Version	IP-protection class	NEMA protection
Plastic	Single chamber	IP 66/IP 67	NEMA 4X/6P
	Double chamber	IP 66/IP 67	NEMA 4X
Aluminium	Single chamber	IP 66/IP 68 (0.2 bar)	NEMA 4X/6P
		IP 68 (1 bar)	-
	Double chamber	IP 66/IP 67	NEMA 4X
		IP 66/IP 68 (0.2 bar)	NEMA 4X
Stainless steel, electro-polished	Single chamber	IP 69K	-
	Single chamber	IP 66/IP 68 (0.2 bar)	NEMA 4X/6P

Housing material	Version	IP-protection class	NEMA protection
Stainless steel, investment casting	Single chamber	IP 66/IP 68 (0.2 bar) IP 68 (1 bar)	NEMA 4X/6P NEMA 4X
	Double chamber	IP 66/IP 67 IP 66/IP 68 (0.2 bar)	NEMA 4X NEMA 4X
Stainless steel	Transmitter for external housing	IP 68 (25 bar)	-

Overvoltage category III

Protection class II

Approvals

Instruments with approvals can have different technical data depending on the version.

For that reason the associated approval documents of these instruments must be carefully noted. They are part of the delivery or can be downloaded under www.vega.com and "VEGA Tools" as well as under "Downloads" and "Approvals".

11.2 Dimensions

The following dimensional drawings represent only an extract of the possible versions. Detailed dimensional drawings can be downloaded at www.vega.com under "Downloads" and "Drawings".

Plastic housing

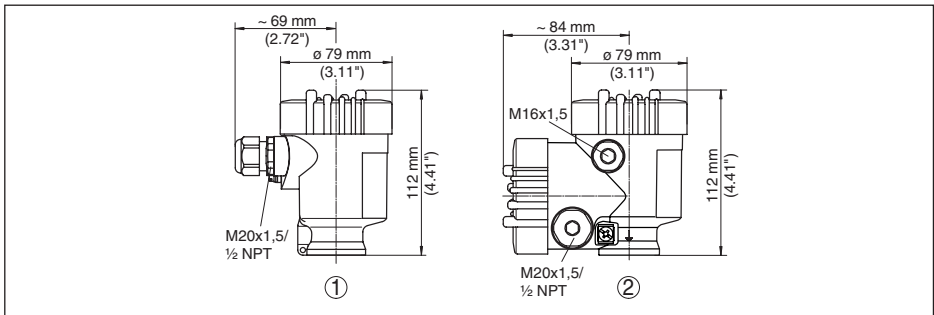

Fig. 45: Housing versions in protection IP 66/IP 68 (0.2 bar) - with integrated display and adjustment module the housing is 9 mm/0.35 in higher

- 1 Single chamber version
- 2 Double chamber version

Aluminium housing

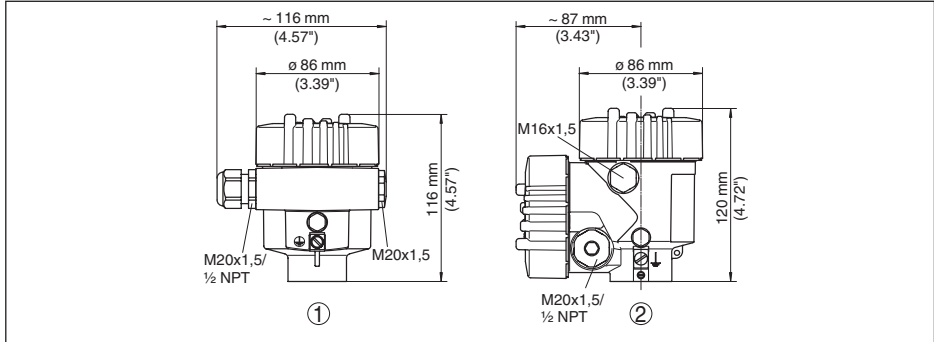

Fig. 46: Housing versions in protection IP 66/IP 68 (0.2 bar) - with integrated display and adjustment module the housing is 9 mm/0.35 in higher

- 1 Single chamber version
- 2 Double chamber version

Aluminium housing in protection rating IP 66/IP 68 (1 bar)

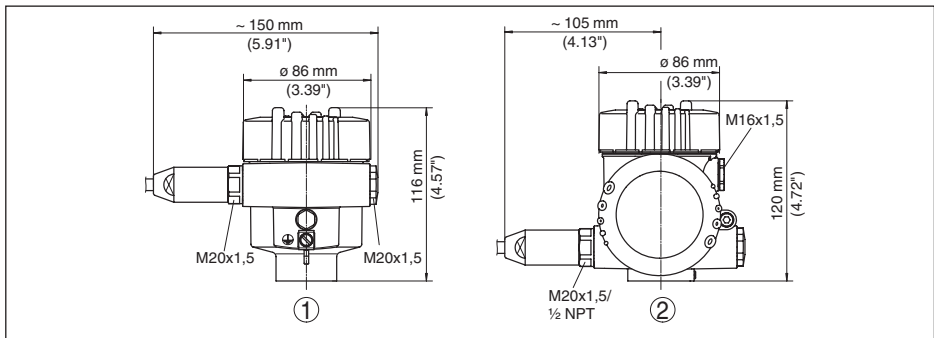

Fig. 47: Housing versions in protection IP 66/IP 68 (1 bar) - with integrated display and adjustment module the housing is 9 mm/0.35 in higher

- 1 Single chamber version
- 2 Double chamber version

Stainless steel housing

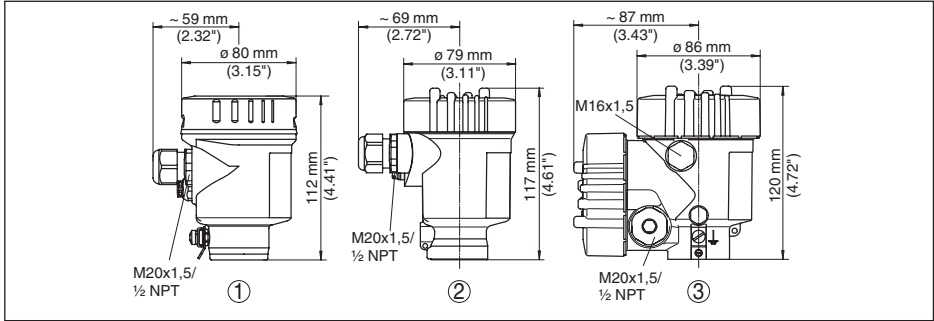

Fig. 48: Housing versions in protection IP 66/IP 68 (0.2 bar) - with integrated display and adjustment module the housing is 9 mm/0.35 in higher

- 1 Single chamber version, electropolished
- 2 Single chamber version, precision casting
- 3 Double chamber version, precision casting

Stainless steel housing in protection rating IP 66/IP 68 (1 bar)

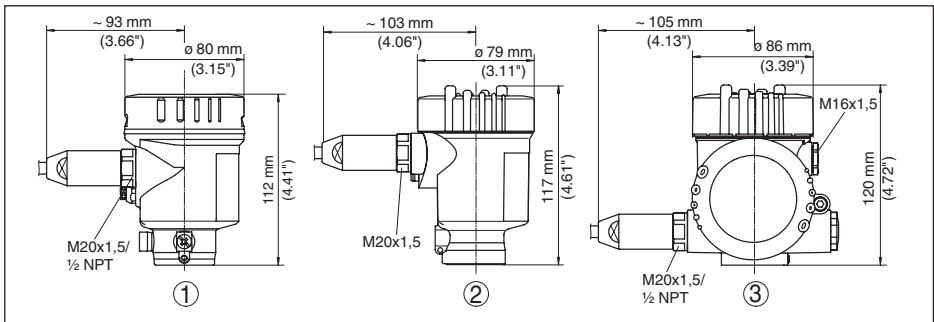

Fig. 49: Housing versions in protection IP 66/IP 68 (1 bar) - with integrated display and adjustment module the housing is 9 mm/0.35 in higher

- 1 Single chamber version, electropolished
- 2 Single chamber version, precision casting
- 3 Double chamber version, precision casting

Stainless steel housing in protection IP 69K

Fig. 50: Housing version in protection IP 69K - ith integrated display and adjustment module the housing is 9 mm/0.35 in higher

1 Single chamber version, electropolished

External housing with IP 68 version

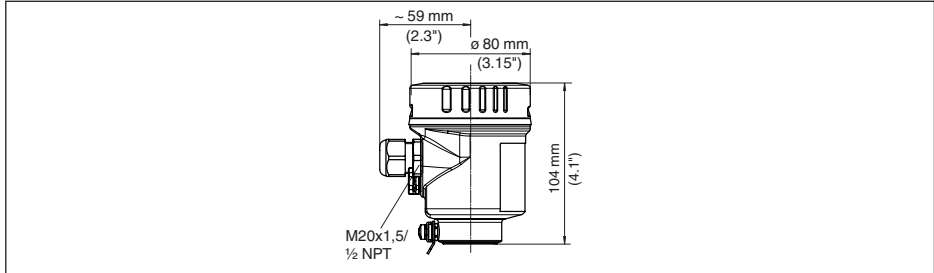
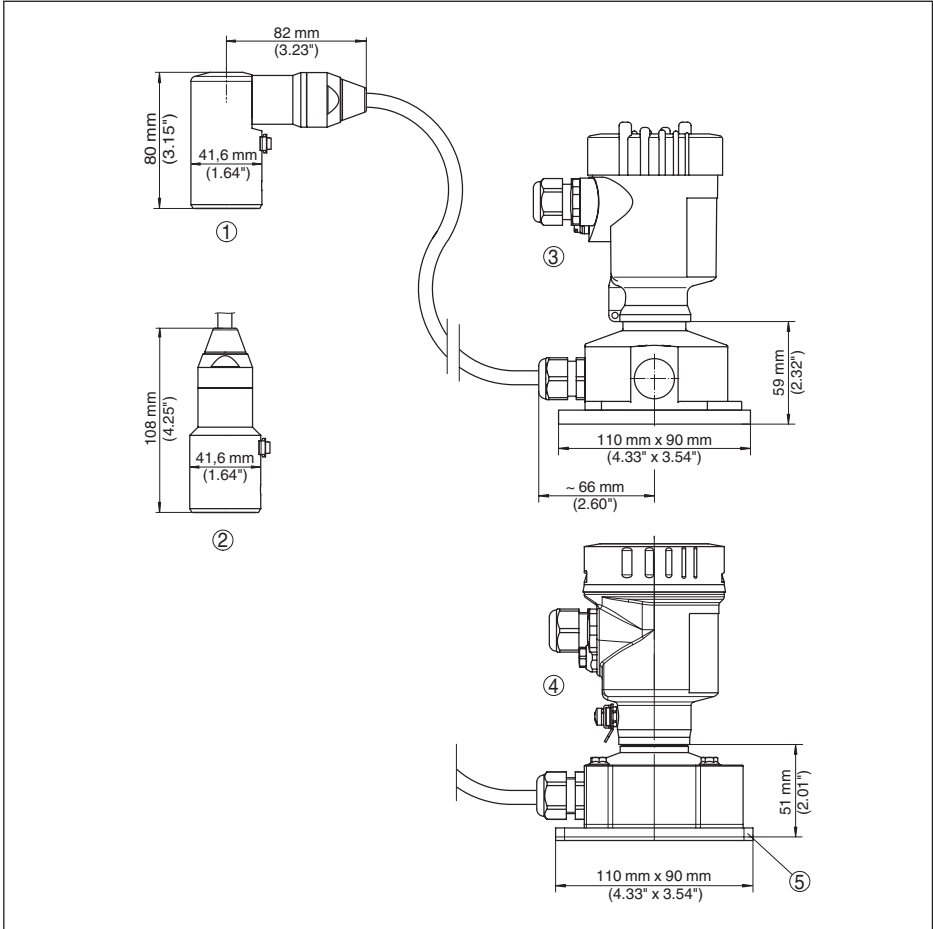

Fig. 51: IP 68 version with external housing - plastic version

- 1 Lateral cable outlet
- 2 Axial cable outlet
- 3 Plastic version
- 4 Stainless steel version
- 5 Seal 2 mm (0.079 in) - only with 3A approval

VEGABAR 83, threaded fitting not front-flush

Fig. 52: VEGABAR 83, threaded fitting not front-flush

- DU $G\frac{1}{2}$ manometer connection (EN 837)
- LT $M20 \times 1.5$ manometer connection (EN 837)
- LE $G\frac{1}{2}$ A inside $G\frac{1}{4}$ (ISO 228-1)
- LF $\frac{1}{2}$ NPT, inside $\frac{1}{4}$ NPT (ASME B1.20.1)
- LY $\frac{1}{2}$ NPT PN 1000

VEGABAR 83, threaded fitting front-flush

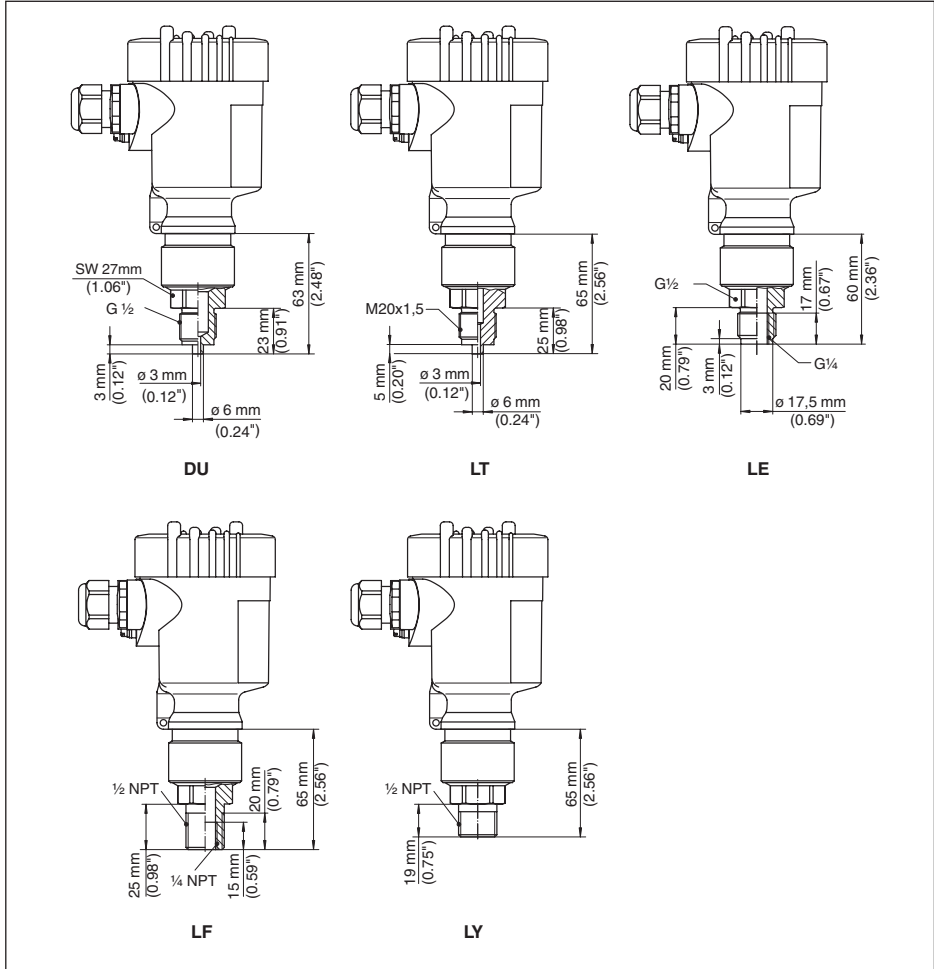
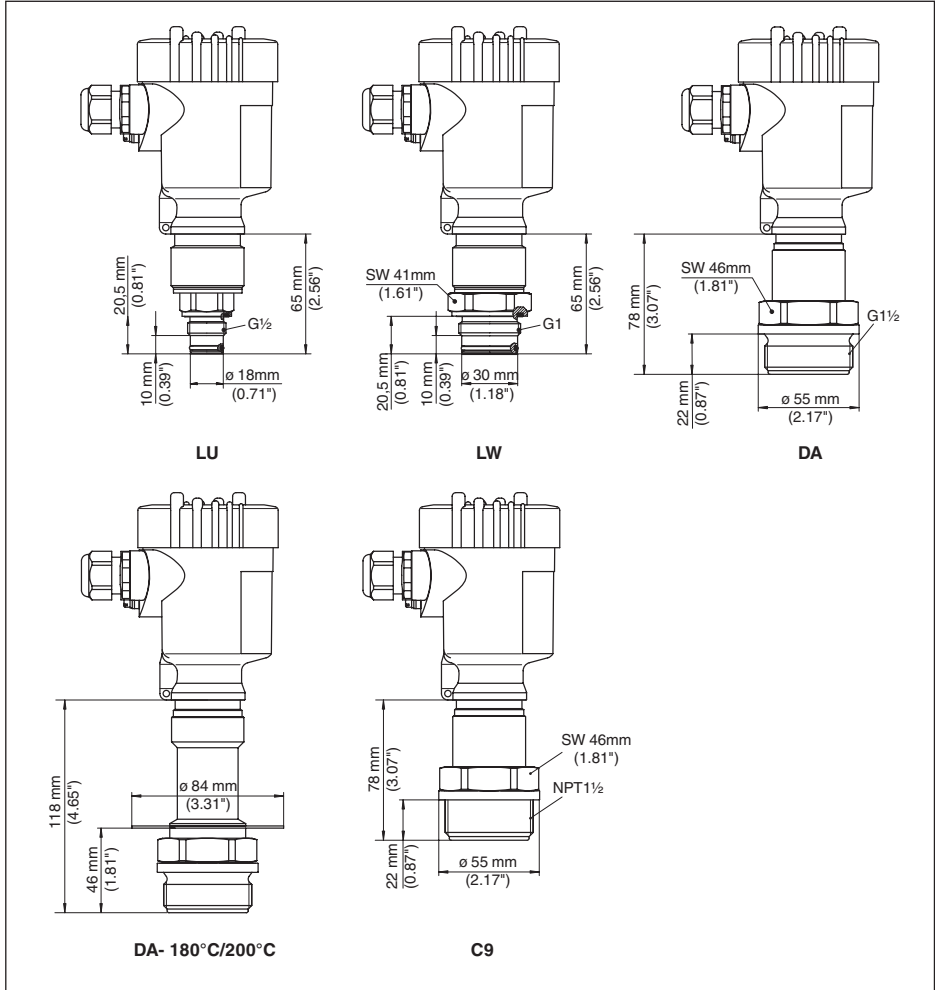

Fig. 53: VEGABAR 83, threaded fitting front-flush

LU G $\frac{1}{2}$ (ISO 228-1) with O-ring

LW G1 (ISO 228-1) with O-ring

DA G $\frac{1}{2}$ (DIN3852-A)

DA G $\frac{1}{2}$ (DIN3852-A) with temperature adapter and screen sheet for 180 °C/200 °C

C9 1 $\frac{1}{2}$ NPT (ASME B1.20.1)

VEGABAR 83, hygienic fitting 150 °C (piezoresistive/strain gauge measuring cell)

Fig. 54: VEGABAR 83, hygienic fitting 105 °C/150 °C (piezoresistive/strain gauge measuring cell)

AR Clamp 2" PN16 (ø64mm) DIN 32676, ISO 2852

ES Hygienic fitting with compression nut F 40 PN 25

FR Varivent N 50-40 PN 25

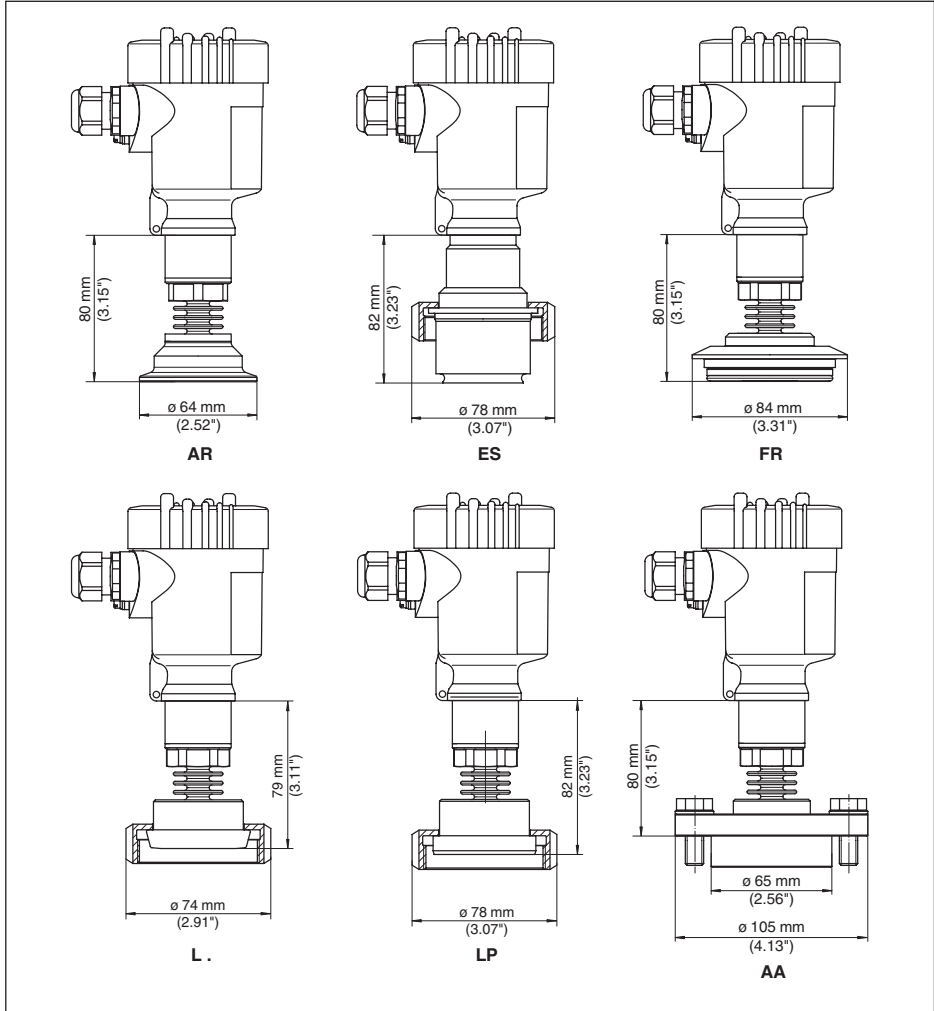
L. Bolting DN 40 PN 40 according to DIN 11851

LP Bolting DN 50 PN 25 Form A DIN 11864

AA DRD PN 40

VEGABAR 83, hygienic fitting 150 °C (METEC® measuring cell)

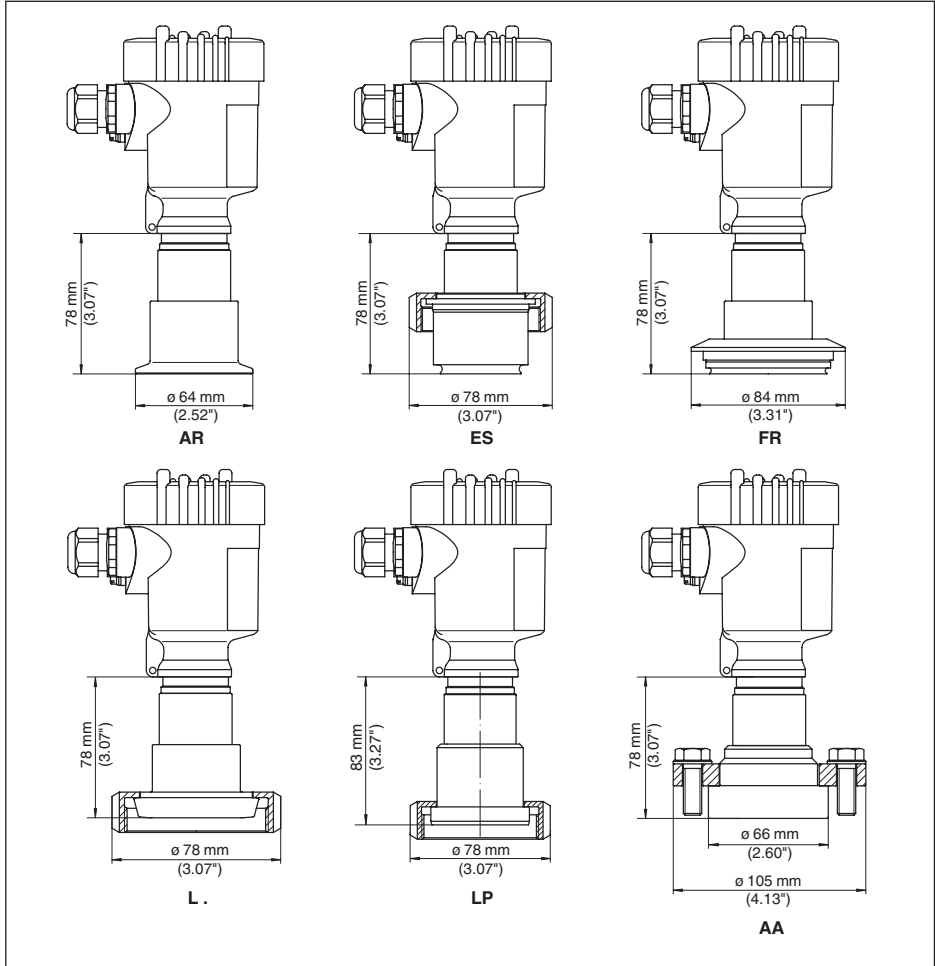

Fig. 55: VEGABAR 83, hygienic fitting 180 °C/200 °C (METEC® measuring cell)

- AR Clamp 2" PN16 ($\varnothing 64$ mm) DIN 32676, ISO 2852
- ES Hygienic fitting with compression nut F 40 PN 25
- FR Varivent N 50-40 PN 25
- L. Bolting DN 40 PN 40 according to DIN 11851
- LP Bolting DN 50 PN 25 Form A DIN 11864
- AA DRD PN 40

VEGABAR 83, flange connection 150 °C (piezoresistive/strain gauge measuring cell)

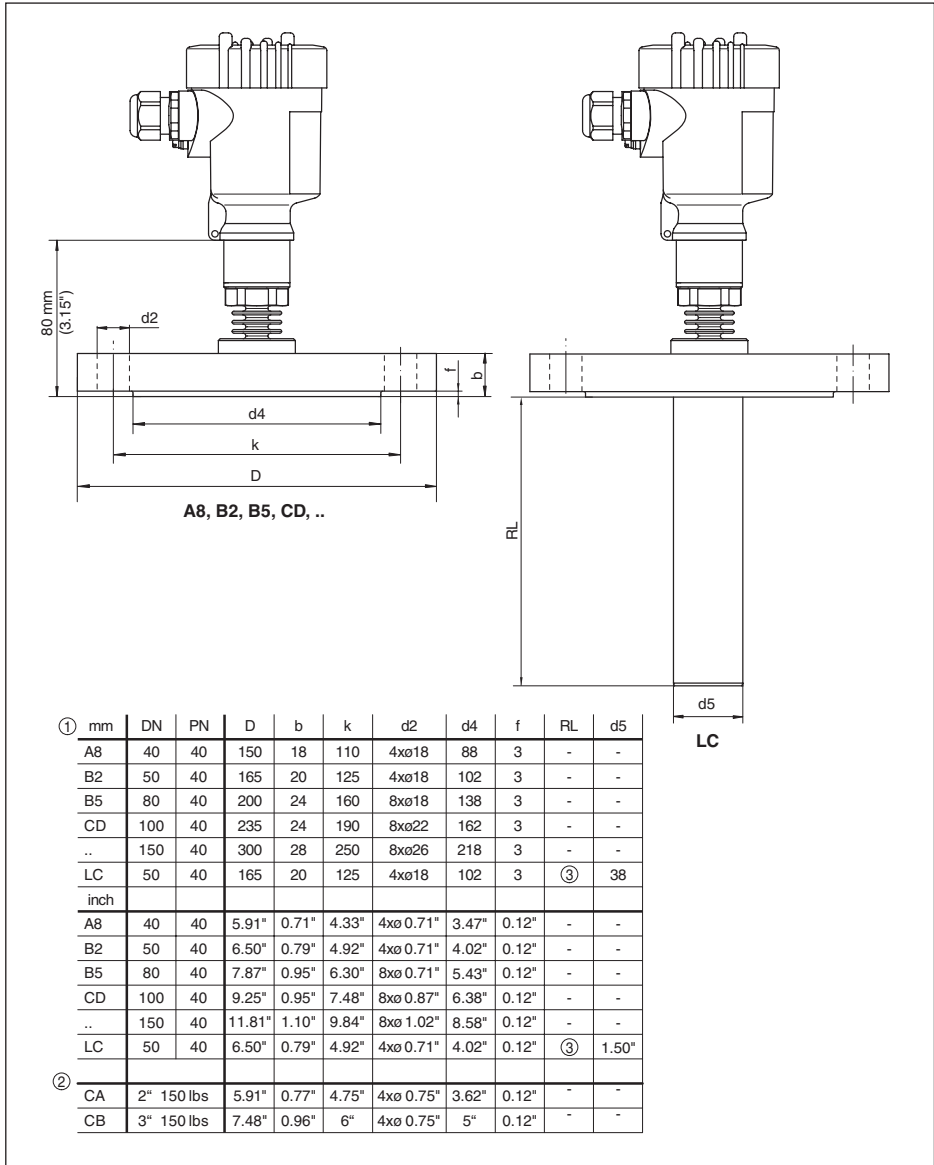

Fig. 56: VEGABAR 83, flange connection

1 Flange connection according to DIN 2501

2 Flange connection according to ASME B16,5

3 Order-specific

VEGABAR 83, flange connection 180 °C/200 °C (METEC® measuring cell)

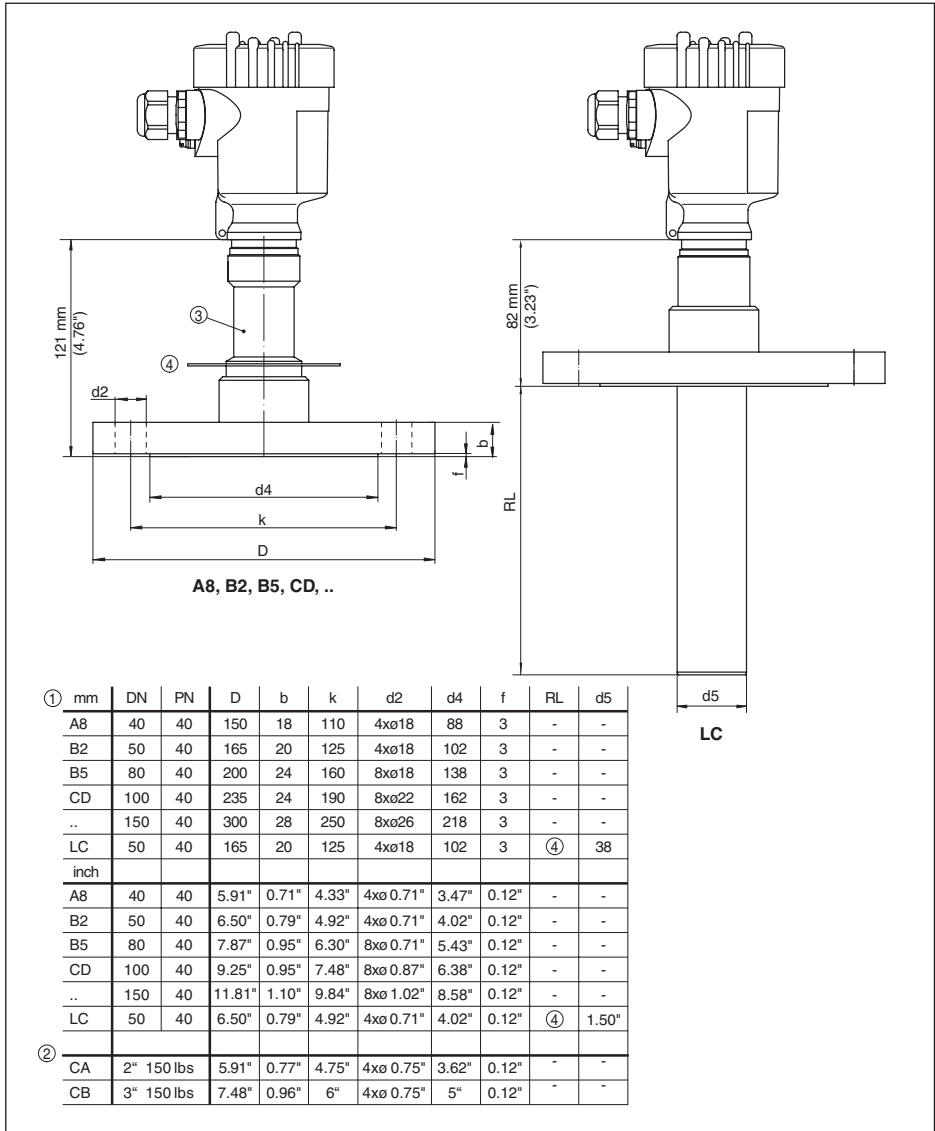

Fig. 57: VEGABAR 83, flange connection

- 1 Flange connection according to DIN 2501
- 2 Flange connection according to ASME B16,5
- 3 Temperature adapter up to 180 °C
- 4 Temperature screen sheet up to 200 °C

11.3 Industrial property rights

VEGA product lines are global protected by industrial property rights. Further information see www.vega.com.

Only in U.S.A.: Further information see patent label at the sensor housing.

VEGA Produktfamilien sind weltweit geschützt durch gewerbliche Schutzrechte.

Nähere Informationen unter www.vega.com.

Les lignes de produits VEGA sont globalement protégées par des droits de propriété intellectuelle. Pour plus d'informations, on pourra se référer au site www.vega.com.

VEGA líneas de productos están protegidas por los derechos en el campo de la propiedad industrial. Para mayor información revise la pagina web www.vega.com.

Линии продукции фирмы ВЕГА защищаются по всему миру правами на интеллектуальную собственность. Дальнейшую информацию смотрите на сайте www.vega.com.

VEGA系列产品在全球享有知识产权保护。

进一步信息请参见网站<www.vega.com>。

11.4 Trademark

All the brands as well as trade and company names used are property of their lawful proprietor/originator.

INDEX**A**

- Adjust Date/Time 44
- Adjustment
 - Level 39
 - Menu 34
 - Process pressure 38
 - System 33
 - Unit 36
- Adjust the current output 41
- Adjust the indication 42

C

- Calculate total deviation 58
- Change the language 42
- Check output signal 57
- Connecting
 - Electrically 22
 - Mechanically 13
 - To the PC 49
- Connection
 - Cable 21
 - Steps 22
 - Technology 22
- Copy sensor settings 46

D

- Damping 40
- Default values 44
- Differential pressure measurement 8
- Display lighting 43

E

- EDD (Enhanced Device Description) 52
- Error codes 54, 56
- Event memory 53

F

- Fault rectification 57
- Functional principle 9

G

- Gas-tight leadthrough (Second Line of Defense)
16
- Grounding 21

H

- HART
 - Address 47
 - Resistor 49

L

- Level measurement 19
- Linearization 40

M

- Maintenance 53
- Measured value memory 53
- Measurement setup
 - In gases 17
 - In liquids 18
 - In the open vessel 19
 - In vapours 17

P

- Peak value
 - Pressure 43
 - Temperature 43
- PIN 44
- Position correction 36
- Pressure compensation 14, 15, 16
- Process pressure measurement 17, 18

R

- Repair 61
- Reset
 - Basic settings 44
 - Delivery status 44

S

- Seal concept 10
- Service
 - Access 46
 - Hotline 58
- Setup
 - Quick setup 33
- Simulation 43
- Status messages - NAMUR NE 107 53

Printing date:

VEGA

All statements concerning scope of delivery, application, practical use and operating conditions of the sensors and processing systems correspond to the information available at the time of printing.

Subject to change without prior notice

© VEGA Grieshaber KG, Schiltach/Germany 2013



45034-EN-131010

VEGA Grieshaber KG
Am Hohenstein 113
77761 Schiltach
Germany

Phone +49 7836 50-0
Fax +49 7836 50-201
E-mail: info.de@vega.com
www.vega.com