

Operating Instructions

Pressure sensor with ceramic measuring cell

VEGABAR 38

Two-wire 4 ... 20 mA



Document ID: 57088



VEGA

Contents

1	About this document	4
1.1	Function	4
1.2	Target group	4
1.3	Symbols used.....	4
2	For your safety	5
2.1	Authorised personnel	5
2.2	Appropriate use.....	5
2.3	Warning about incorrect use.....	5
2.4	General safety instructions	5
2.5	EU conformity.....	6
2.6	Installation and operation in the USA and Canada	6
2.7	Safety instructions for Ex areas	6
3	Product description	7
3.1	Configuration.....	7
3.2	Principle of operation.....	9
3.3	Adjustment	12
3.4	Packaging, transport and storage.....	12
3.5	Accessories.....	13
4	Mounting	14
4.1	General instructions	14
4.2	Process pressure measurement.....	16
4.3	Level measurement.....	18
5	Connecting to power supply	19
5.1	Preparing the connection	19
5.2	Connection procedure.....	19
5.3	Wiring plan - Two-wire 4 ... 20 mA.....	22
5.4	Switch-on phase.....	23
6	Access protection	24
6.1	Bluetooth radio interface	24
6.2	Protection of the parameterization.....	24
7	Set up with the integrated display and adjustment unit	26
7.1	Adjustment system	26
7.2	Measured value and menu item display	27
7.3	Menu overview	28
7.4	Parameter adjustment	29
8	Setup with smartphone/tablet (Bluetooth)	36
8.1	Preparations.....	36
8.2	Connecting.....	36
8.3	Sensor parameter adjustment.....	37
9	Setup with PC/notebook (Bluetooth)	38
9.1	Preparations.....	38
9.2	Connecting.....	38
9.3	Parameter adjustment	39
10	Diagnostics and servicing	40

10.1	Maintenance	40
10.2	Rectify faults.....	40
10.3	Diagnosis, fault messages	41
10.4	Status messages according to NE 107	41
10.5	Software update	43
10.6	How to proceed if a repair is necessary.....	43
11	Dismount.....	45
11.1	Dismounting steps.....	45
11.2	Disposal	45
12	Certificates and approvals.....	46
12.1	Environmental instructions	46
13	Supplement	47
13.1	Technical data	47
13.2	Dimensions	54
13.3	Industrial property rights.....	59
13.4	Hash function acc. to mbed TLS.....	59
13.5	Trademark.....	59

1 About this document

1.1 Function

This instruction provides all the information you need for mounting, connection and setup as well as important instructions for maintenance, fault rectification, the exchange of parts and the safety of the user. Please read this information before putting the instrument into operation and keep this manual accessible in the immediate vicinity of the device.

1.2 Target group

This operating instructions manual is directed to trained personnel. The contents of this manual must be made available to the qualified personnel and implemented.

1.3 Symbols used



Document ID

This symbol on the front page of this instruction refers to the Document ID. By entering the Document ID on www.vega.com you will reach the document download.



Information, note, tip: This symbol indicates helpful additional information and tips for successful work.



Note: This symbol indicates notes to prevent failures, malfunctions, damage to devices or plants.



Caution: Non-observance of the information marked with this symbol may result in personal injury.



Warning: Non-observance of the information marked with this symbol may result in serious or fatal personal injury.



Danger: Non-observance of the information marked with this symbol results in serious or fatal personal injury.



Ex applications

This symbol indicates special instructions for Ex applications.



List

The dot set in front indicates a list with no implied sequence.



Sequence of actions

Numbers set in front indicate successive steps in a procedure.



Battery disposal

This symbol indicates special information about the disposal of batteries and accumulators.

2 For your safety

2.1 Authorised personnel

All operations described in this documentation must be carried out only by trained, qualified personnel authorised by the plant operator.

During work on and with the device, the required personal protective equipment must always be worn.

2.2 Appropriate use

The VEGABAR 38 is a pressure transmitter for process pressure and hydrostatic level measurement.

You can find detailed information about the area of application in chapter "*Product description*".

Operational reliability is ensured only if the instrument is properly used according to the specifications in the operating instructions manual as well as possible supplementary instructions.

2.3 Warning about incorrect use

Inappropriate or incorrect use of this product can give rise to application-specific hazards, e.g. vessel overfill through incorrect mounting or adjustment. Damage to property and persons or environmental contamination can result. Also, the protective characteristics of the instrument can be impaired.

2.4 General safety instructions

This is a state-of-the-art instrument complying with all prevailing regulations and directives. The instrument must only be operated in a technically flawless and reliable condition. The operator is responsible for the trouble-free operation of the instrument. When measuring aggressive or corrosive media that can cause a dangerous situation if the instrument malfunctions, the operator has to implement suitable measures to make sure the instrument is functioning properly.

During the entire duration of use, the user is obliged to determine the compliance of the necessary occupational safety measures with the current valid rules and regulations and also take note of new regulations.

The safety instructions in this operating instructions manual, the national installation standards as well as the valid safety regulations and accident prevention rules must be observed by the user.

For safety and warranty reasons, any invasive work on the device beyond that described in the operating instructions manual may be carried out only by personnel authorised by the manufacturer. Arbitrary conversions or modifications are explicitly forbidden. For safety reasons, only the accessory specified by the manufacturer must be used.

To avoid any danger, the safety approval markings and safety tips on the device must also be observed.

2.5 EU conformity

The device fulfils the legal requirements of the applicable EU directives. By affixing the CE marking, we confirm the conformity of the instrument with these directives.

The EU conformity declaration can be found on our homepage.

Due to the design of its process fittings, the device does not subject of EU pressure device directive if it is operated at process pressures ≤ 200 bar.

2.6 Installation and operation in the USA and Canada

This information is only valid for USA and Canada. Hence the following text is only available in the English language.

Installations in the US shall comply with the relevant requirements of the National Electrical Code (ANSI/NFPA 70).

Installations in Canada shall comply with the relevant requirements of the Canadian Electrical Code.

2.7 Safety instructions for Ex areas

For Ex applications, only devices with corresponding Ex approval may be used. Observe the Ex-specific safety instructions. These are an integral part of the operating instructions and are enclosed with every device with Ex approval.

3 Product description

3.1 Configuration

Scope of delivery

The scope of delivery encompasses:

- VEGABAR 38 pressure transmitter
- Information sheet "*Documents and software*" with:
 - Instrument serial number
 - QR code with link for direct scanning
- Information sheet "*PINs and Codes*" with:
 - Bluetooth access code
 - DataMatrix code with link for direct scanning
- Information sheet "*Emergency unlock codes*" with:
 - Bluetooth access code
 - Bluetooth unlock code
 - Device unlock code

The further scope of delivery encompasses:

- Documentation
 - Ex-specific "*Safety instructions*" (with Ex versions)
 - If necessary, further certificates



Note:

Optional instrument features are also described in this operating instructions manual. The respective scope of delivery results from the order specification.

Scope of this operating instructions

This operating instructions manual applies to the following instrument versions:

- Hardware version from 1.0.0
- Software version from 1.1.0

Constituent parts

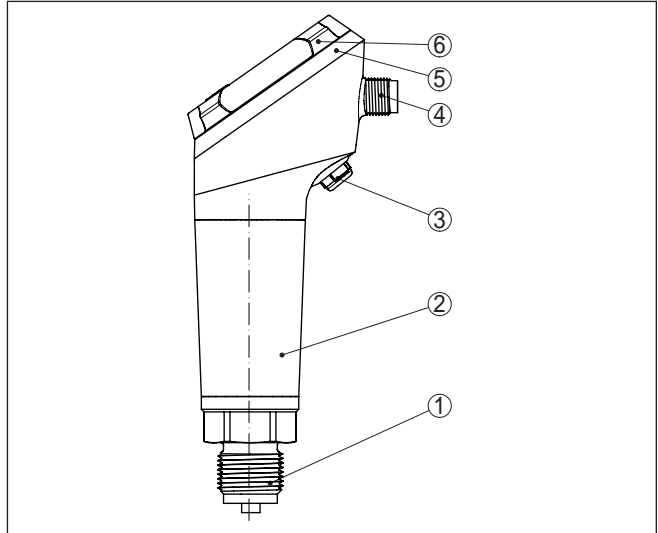

Fig. 1: Components of VEGABAR 38

- 1 *Process fitting*
- 2 *Electronics housing*
- 3 *Ventilation/pressure compensation*
- 4 *Plug connector*
- 5 *LED illuminated ring*
- 6 *Display/adjustment unit*

Type label

The type label contains the most important data for identification and use of the instrument.

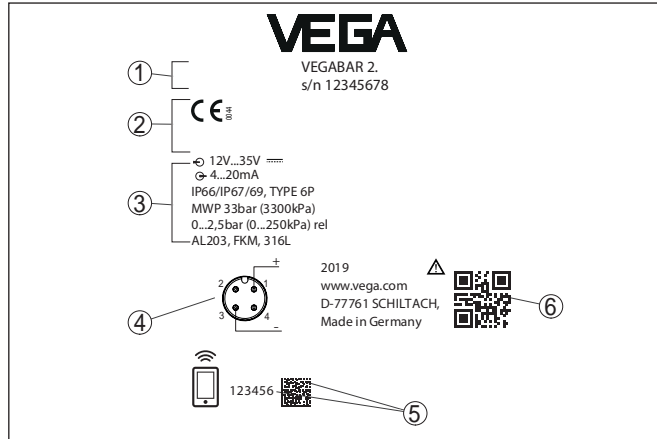

Fig. 2: Layout of the type label (example)

- 1 Sensor type and serial number
- 2 Field for approvals
- 3 Technical data
- 4 Assignment
- 5 Number or DataMatrix code for Bluetooth access
- 6 QR code for device documentation

Documents and software Move to "www.vega.com" and enter in the search field the serial number of your instrument.

There you can find the following information about the instrument:

- Order data
- Documentation
- Software

Alternatively, you can find all via your smartphone:

- Scan the QR-code on the type label of the device or
- Enter serial number manually in the VEGA Tools app (available free of charge in the respective stores)

3.2 Principle of operation

Application area

VEGABAR 38 is suitable for applications in virtually all industries. It is used for the measurement of the following pressure types.

- Gauge pressure
- Absolute pressure
- Vacuum

Measured products

Measured products are gases, vapours and liquids.

Depending on the process fitting and measurement setup, measured products can be also viscous or contain abrasive substances.

Measured variables

The VEGABAR 38 is suitable for the measurement of the following process variables:

- Process pressure
- Level

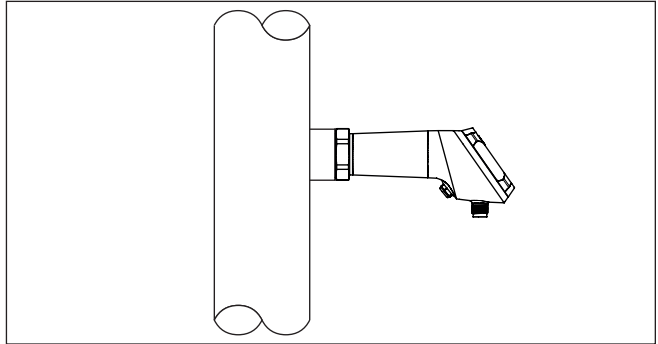

Fig. 3: Process pressure measurement VEGABAR 38

Measuring system pressure

The sensor element is the Mini-CERTEC® measuring cell with robust ceramic diaphragm. The process pressure deflects the ceramic diaphragm and causes a capacitance change in the measuring cell. This capacitance change is converted into an electrical signal and outputted as measured value via the output signal.

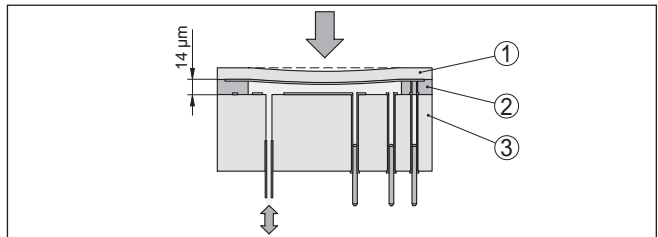

Fig. 4: Configuration of the Mini-CERTEC® measuring cell

- 1 Process diaphragm
- 2 Glass joint
- 3 Base element

Measuring system temperature

A temperature sensor in the electronics of the Mini-CERTEC® measuring cell measures the current process temperature. The temperature value is output via Bluetooth or the display.

Pressure types

Relative pressure: the measuring cell is open to the atmosphere. The ambient pressure is detected in the measuring cell and compensated. It thus has no influence on the measured value.

Absolute pressure: the measuring cell contains vacuum and is encapsulated. The ambient pressure is not compensated and does hence influence the measured value.

Recessed installation

The recessed installation is particularly suitable for applications with gases, vapours and clear liquids. The measuring cell seals are positioned laterally as well as in front.

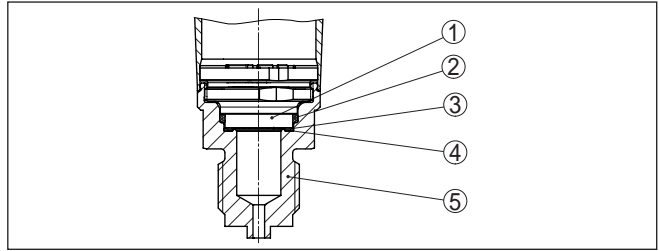

Fig. 5: Recessed installation of the measuring cell (example: manometer connection G½)

- 1 Measuring cell
- 2 Lateral measuring cell seal
- 3 Front measuring cell seal
- 4 Diaphragm
- 5 Process fitting

Front flush installation

The front-flush installation is particularly suitable for applications with viscous or abrasive media and for buildup.

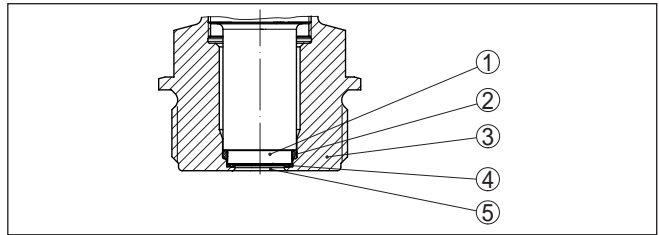

Fig. 6: Front-flush installation of the measuring cell (example: thread G1½)

- 1 Measuring cell
- 2 Lateral measuring cell seal
- 3 Front measuring cell seal
- 4 Process fitting
- 5 Diaphragm

Front-flush installation in hygienic fitting

The front-flush, hygienic installation of the measuring cell is particularly suitable for food applications. The front seal is installed gap-free.

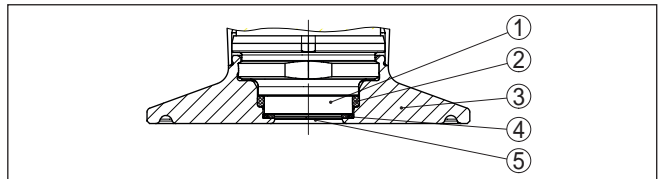

Fig. 7: Hygienic installation of the measuring cell (example: Clamp 2")

- 1 Measuring cell
- 2 Lateral measuring cell seal
- 3 Process fitting
- 4 Front measuring cell seal
- 5 Diaphragm

3.3 Adjustment

Local adjustment

The integrated display and adjustment unit is used for on-site adjustment of VEGABAR 38.



Note:

The housing with display and adjustment unit can be rotated 330° for optimum readability and operability without tools.

Wireless adjustment

Devices with integrated Bluetooth module can be adjusted wirelessly via standard adjustment tools:

- Smartphone/tablet (iOS or Android operating system)
- PC/notebook (Windows operating system)

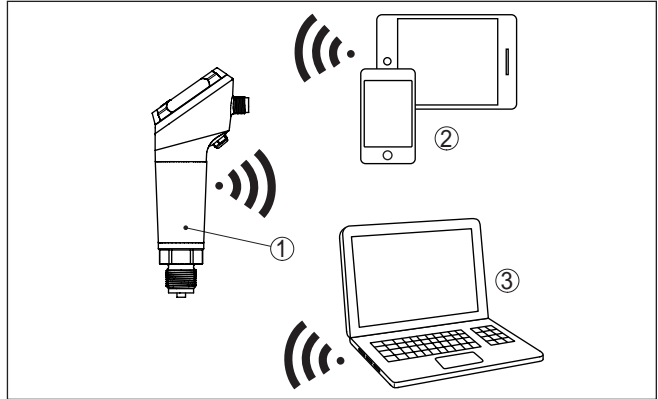

Fig. 8: Wireless connection to standard operating devices with integrated Bluetooth LE

- 1 Sensor
- 2 Smartphone/Tablet
- 3 PC/Notebook

3.4 Packaging, transport and storage

Packaging

Your instrument was protected by packaging during transport. Its capacity to handle normal loads during transport is assured by a test based on ISO 4180.

The packaging consists of environment-friendly, recyclable cardboard. For special versions, PE foam or PE foil is also used. Dispose of the packaging material via specialised recycling companies.

Transport

Transport must be carried out in due consideration of the notes on the transport packaging. Nonobservance of these instructions can cause damage to the device.

Transport inspection

The delivery must be checked for completeness and possible transit damage immediately at receipt. Ascertained transit damage or concealed defects must be appropriately dealt with.

Storage

Up to the time of installation, the packages must be left closed and stored according to the orientation and storage markings on the outside.

Unless otherwise indicated, the packages must be stored only under the following conditions:

- Not in the open
- Dry and dust free
- Not exposed to corrosive media
- Protected against solar radiation
- Avoiding mechanical shock and vibration

Storage and transport temperature

The permissible storage and transport temperatures can be found in chapter "*Supplement - Technical data - Ambient conditions*"

3.5 Accessories

The instructions for the listed accessories can be found in the download area on our homepage.

Welded sockets and adapters

Welded sockets are used to connect the sensors to the process.

Threaded adapters enable simple adaptation of sensors with standard threaded fittings, e.g. to process-side hygiene connections.

Mounting accessories

The suitable mounting accessories for VEGABAR 38 includes siphons, blocking valves and measuring instrument holders.

4 Mounting

4.1 General instructions

Ambient conditions

The instrument is suitable for standard and extended ambient conditions acc. to DIN/EN/IEC/ANSI/ISA/UL/CSA 61010-1. It can be used indoors as well as outdoors.

Process conditions



Note:

For safety reasons, the instrument must only be operated within the permissible process conditions. You can find detailed information on the process conditions in chapter "*Technical data*" of the operating instructions or on the type label.

Hence make sure before mounting that all parts of the instrument exposed to the process are suitable for the existing process conditions.

These are mainly:

- Active measuring component
- Process fitting
- Process seal

Process conditions in particular are:

- Process pressure
- Process temperature
- Chemical properties of the medium
- Abrasion and mechanical influences

Permissible process pressure (MWP)

The permissible process pressure range is specified by "MWP" (Maximum Working Pressure) on the type label, see chapter "*Structure*". The MWP takes the element of the measuring cell and processing fitting combination with the weakest pressure into consideration and may be applied permanently. The specification refers to a reference temperature of +20 °C (+68 °F). It also applies when a measuring cell with a higher measuring range than the permissible pressure range of the process fitting is installed order-related.

In order to prevent damage to the device, the test pressure may only exceed the specified MWP briefly by 1.5 times at reference temperature. The pressure stage of the process fitting as well as the overload resistance of the measuring cell are taken into consideration here (see chapter "*Technical Data*").

In addition, a temperature derating of the process fitting, e. g. with flanges, can limit the permissible process pressure range according to the respective standard.

Protection against moisture

Protect your instrument against moisture ingress through the following measures:

- Use a suitable connection cable (see chapter "*Connecting to power supply*")
- Tighten the cable gland or plug connector
- When mounting horizontally, rotate the housing so that the cable gland or plug connector point downward

- Lead the connection cable downward in front of the cable entry or plug connector

This applies mainly to outdoor installations, in areas where high humidity is expected (e.g. through cleaning processes) and on cooled or heated vessels.

Make sure that the degree of contamination specified in chapter "Technical data" meets the existing ambient conditions.

Ventilation and pressure compensation

Ventilation and pressure compensation for VEGABAR 38 are provided by an air-permeable, moisture-blocking filter element.



Note:

In case of horizontal mounting, turn the housing so that the filter element points downward after the instrument is installed. This provides better protection against buildup.

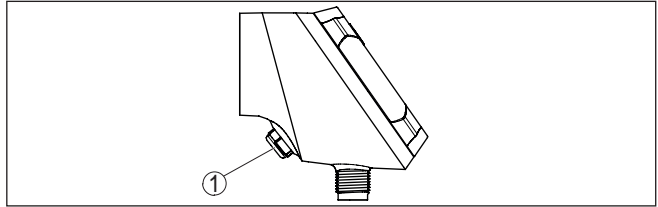

Fig. 9: Position of the filter element

1 Filter element

For effective ventilation, the filter element must always be free of buildup.

Screwing in

On devices with a threaded fitting, the hexagon on the process fitting must be tightened with a suitable wrench.

See chapter "Dimensions" for wrench size.



Warning:

The housing or the electrical connection may not be used for screwing in! Depending on the device version, tightening can cause damage, e.g. to the rotation mechanism of the housing.

Process pressure range - Mounting accessory

The permissible process pressure range is stated on the type label. The instrument should only be operated with these pressures if the mounting accessory used also fulfils these values. This should be ensured by suitable flanges, welded sockets, tension rings with Clamp connections, sealings, etc.

Temperature limits

Higher process temperatures often mean also higher ambient temperatures. Make sure that the upper temperature limits stated in chapter "Technical data" for the environment of the electronics housing and connection cable are not exceeded.

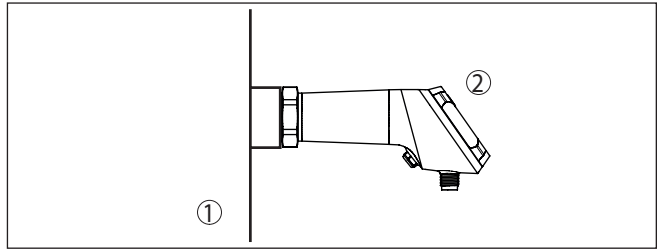

Fig. 10: Temperature ranges

- 1 Process temperature
- 2 Ambient temperature

In gases

4.2 Process pressure measurement

Keep the following in mind when setting up the measuring system:

- Mount the instrument above the measuring point

Possible condensation can then drain off into the process line.

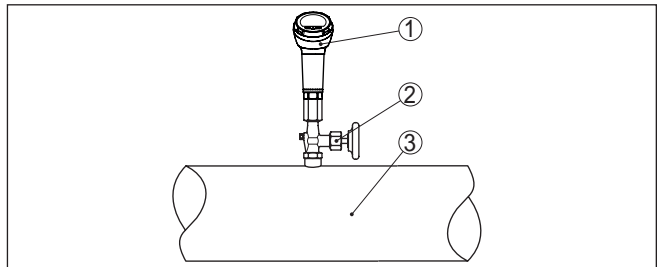

Fig. 11: Measurement setup for process pressure measurement of gases in pipelines

- 1 VEGABAR 38
- 2 Blocking valve
- 3 Pipeline

In vapours

Keep the following in mind when setting up the measuring system:

- Connect via a siphon

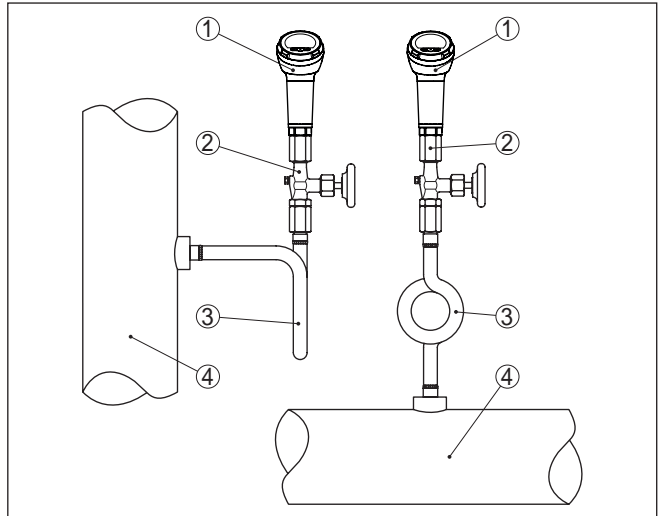

Fig. 12: Measurement setup for process pressure measurement of gases in pipelines

- 1 VEGABAR 38
- 2 Blocking valve
- 3 Siphon in U or circular form
- 4 Pipeline

A protective accumulation of water is formed through condensation in the pipe bends. Even in applications with hot steam, a medium temperature < 100 °C on the transmitter is ensured.

In liquids

Keep the following in mind when setting up the measuring system:

- Mount the instrument below the measuring point

The effective pressure line is always filled with liquid and gas bubbles can bubble up to the process line.

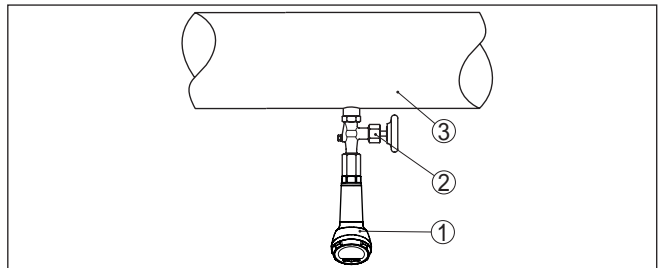

Fig. 13: Measurement setup for process pressure measurement of liquids in pipelines

- 1 VEGABAR 38
- 2 Blocking valve
- 3 Pipeline

4.3 Level measurement

Measurement setup

Keep the following in mind when setting up the measuring system:

- Mount the instrument below the min. level
- Do not mount the instrument close to the filling stream or emptying area
- Mount the instrument so that it is protected against pressure shocks from the stirrer

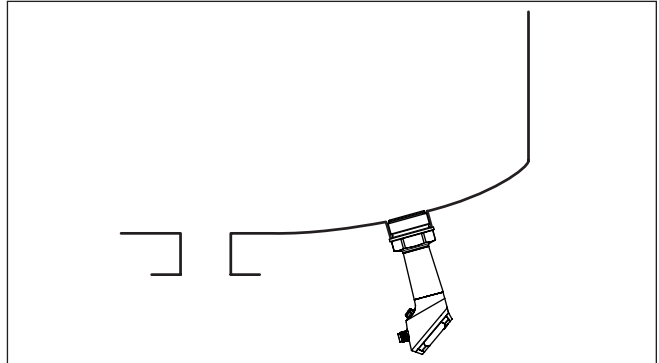

Fig. 14: Measurement setup for level measurement

5 Connecting to power supply

5.1 Preparing the connection

Safety instructions

Always keep in mind the following safety instructions:

- Carry out electrical connection by trained, qualified personnel authorised by the plant operator
- If overvoltage surges are expected, overvoltage arresters should be installed



Warning:

Only connect or disconnect in de-energized state.

Voltage supply

The data for power supply are specified in chapter "*Technical data*".



Note:

Power the instrument via an energy-limited circuit (power max. 100 W) acc. to IEC 61010-1, e.g.

- Class 2 power supply unit (acc. to UL1310)
- SELV power supply unit (safety extra-low voltage) with suitable internal or external limitation of the output current

Keep in mind the following additional factors that influence the operating voltage:

- Lower output voltage of the power supply unit under nominal load (e.g. with a sensor current of 20.5 mA or 22 mA in case of fault)
- Influence of additional instruments in the circuit (see load values in chapter "*Technical data*")

Connection cable

Use cable with round cross section. Depending on the plug connection, you have to select the outer diameter of the cable respectively so that the seal effect of the cable gland is ensured.

Depending on the connection method or signal output, the device is connected with standard two, three or four-wire cable without shielding.

5.2 Connection procedure

M12 x 1 plug

This plug connection requires a complete confectioned cable with counter plug.

Plug according to ISO 4400

Proceed as follows:

1. Loosen the screw on the rear of the plug connector
2. Remove the plug connector and seal from VEGABAR 38
3. Remove the plug insert from the plug housing

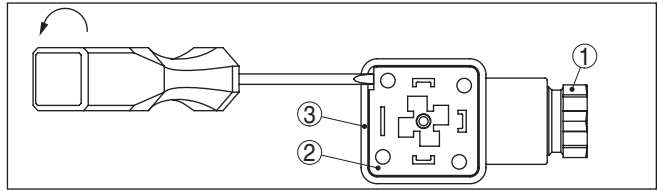

Fig. 15: Loosen the plug insert

- 1 Cable gland
- 2 Plug insert
- 3 Plug housing

- 4. Remove approx. 5 cm of the cable mantle, strip approx. 1 cm insulation from the individual wires
- 5. Lead the cable through the cable gland into the plug housing
- 6. Connect the wire ends to the screw terminals according to the wiring plan

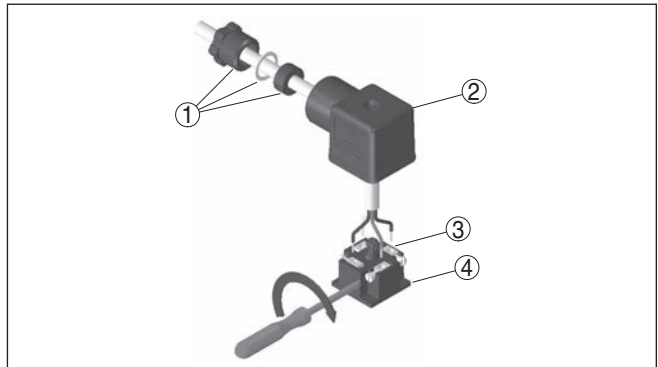

Fig. 16: Connection to the screw terminals

- 1 Cable gland
- 2 Plug housing
- 3 Plug insert
- 4 Plug seal

- 7. Snap the plug insert into the plug housing and insert the sensor seal
- 8. Plug the plug insert with seal to VEGABAR 38 and tighten the screw

The electrical connection is finished.

ISO 4400 plug with hinged cover

Proceed as follows:

- 1. Loosen the screw in the cover of the plug connector
- 2. Open the cover and remove it
- 3. Press the plug insert downwards
- 4. Loosen the screws of the strain relief and cable entry

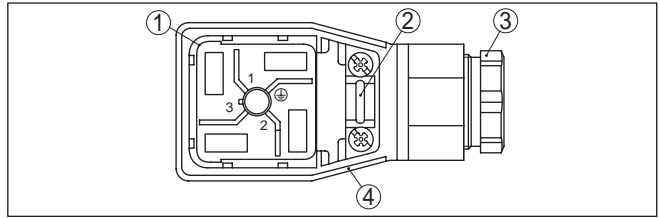

Fig. 17: Loosen the plug insert

- 1 Plug insert
- 2 Strain relief
- 3 Cable gland
- 4 Plug housing

- 5. Remove approx. 5 cm of the cable mantle, strip approx. 1 cm insulation from the individual wires
- 6. Lead the cable through the cable gland into the plug housing
- 7. Connect the wire ends to the screw terminals according to the wiring plan

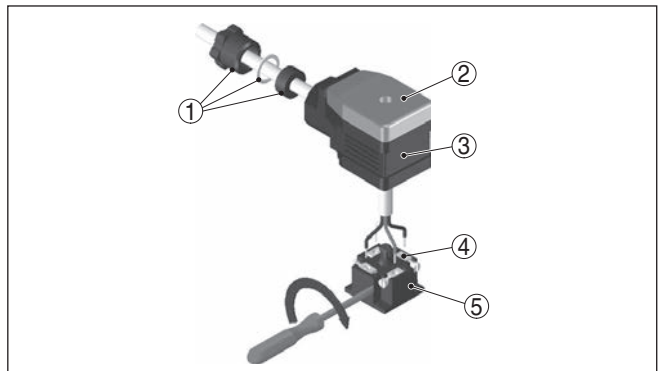

Fig. 18: Connection to the screw terminals

- 1 Cable gland
- 2 Cover
- 3 Plug housing
- 4 Plug insert
- 5 Plug seal

- 8. Snap the plug insert into the plug housing and insert the sensor seal



Information:

Note the correct arrangement, see illustration

- 9. Tighten the screws on the strain relief and cable entry
- 10. Hook in the cover and push onto the plug connection, tighten cover screw
- 11. Plug the plug insert with seal to VEGABAR 38 and tighten the screw

The electrical connection is finished.

Plug according to ISO 4400 with IDC method of termination

For this plug version you can use standard cable with round wire cross-section. The inner conductors do not have to be stripped. The plug connects the conductors automatically when screwing in. Cable diameter 5.5 ... 8 mm, protection IP67.

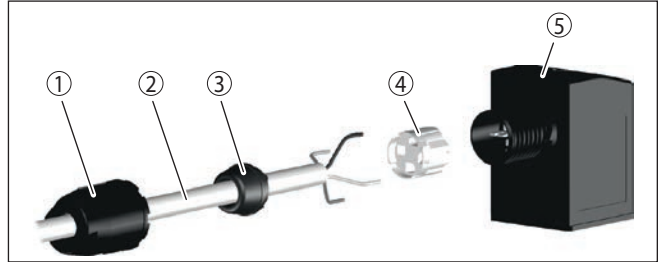

Fig. 19: Connection, valve plug ISO 4400 with IDC crimping technology

- 1 Compression nut
- 2 Cable
- 3 Seal ring
- 4 Terminal insert
- 5 Plug housing

Plug according to ISO 4400

5.3 Wiring plan - Two-wire 4 ... 20 mA

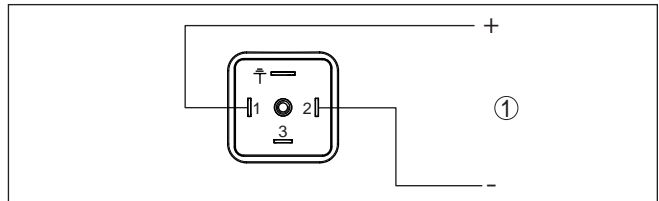



Fig. 20: Wiring plan - two-wire 4 ... 20 mA - plug according to ISO 4400

- 1 Voltage supply and signal output

Contact, plug connector	Function/Polarity
1	Voltage supply, signal output/+
2	Voltage supply, signal output/-
3	Free
	Electrically connected with metal housing

M12 x 1 plug

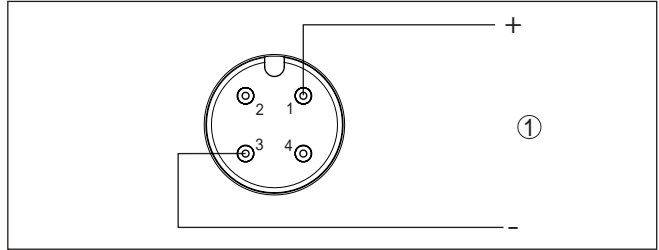

Fig. 21: Wiring plan - two-wire 4 ... 20 mA - M12 x 1 plug

1 Voltage supply and signal output

Contact, plug connector	Function/Polarity
1	Voltage supply, signal output/+
2	Free
3	Voltage supply, signal output/-
4	Free

5.4 Switch-on phase

After switching on, the device first carries out a self-check:

- Internal check of the electronics
- The output signal jumps to the set fault current

The current measured value is then output on the signal cable.

6 Access protection

6.1 Bluetooth radio interface

Devices with a Bluetooth radio interface are protected against unwanted access from outside. This means that only authorized persons can receive measured and status values and change device settings via this interface.

Bluetooth access code

A Bluetooth access code is required to establish Bluetooth communication via the adjustment tool (smartphone/tablet/notebook). This code must be entered once when Bluetooth communication is established for the first time in the operating device. It is then stored in the adjustment tool and does not have to be entered again.

The Bluetooth access code is individual for each device. It is printed on the device housing and is also supplied with the device in the information sheet "*PINs and Codes*". It can be changed by the user after the first connection has been established. If the Bluetooth access code has not been entered correctly, a new entry can only be made after a waiting period has elapsed. The waiting time increases with each additional incorrect entry.

If the user has a "*myVEGA*" account, the Bluetooth access code is additionally stored in his account under "*PINs and Codes*". This greatly simplifies the use of additional adjustment tools, as all Bluetooth access codes are automatically synchronized when connected to the "*myVEGA*" account

Emergency Bluetooth unlock code

The emergency Bluetooth unlock code enables Bluetooth communication to be established in the event that the Bluetooth access code is no longer known. It can't be changed. The "Emergency Bluetooth unlock code" can also be found in information sheet "*Emergency codes*". If this document is lost, the emergency Bluetooth unlock code can be retrieved from your VEGA contact person after legitimation. The storage and transmission of Bluetooth access codes is always encrypted (SHA 56 algorithm).

6.2 Protection of the parameterization

The settings (parameters) of the device can be protected against unwanted changes. The device is not locked on delivery, all settings can be made.

Device code

To protect the parameterization, the device can be locked by the user with the aid of a freely selectable device code. The settings (parameters) can then only be read out, but not changed. The device code is also stored in the adjustment tool. However, it must be re-entered for each unlocking. When using the VEGA Tools app, the stored device code is then suggested to the user for unlocking.

If the user has a "*myVEGA*" account, the device code is additionally stored in his account under "*PINs and Codes*". This greatly simplifies the setup of additional operating devices, as all device codes are automatically synchronized when connected to the "*myVEGA*" account.

Emergency device unlock code

The emergency device unlock code allows unlocking the devices in case the device code is no longer known. It can't be changed. The emergency device unlock code can also be found on the supplied information sheet "*Emergency codes*". If this document is lost, the emergency device unlock code can be retrieved from your VEGA contact person after legitimation. The storage and transmission of the device codes is always encrypted (SHA 256 algorithm).

7 Set up with the integrated display and adjustment unit

7.1 Adjustment system

Function

The instrument is operated via the three keys of the integrated display and adjustment unit. The respective menu items are shown on the LC display. You can find the function of the individual keys in the following overview.

Certain setting options are not possible or only possible to a limited extent with the integrated display and adjustment unit. For these applications the use of PACTware with corresponding DTM is recommended.

Display and adjustment elements

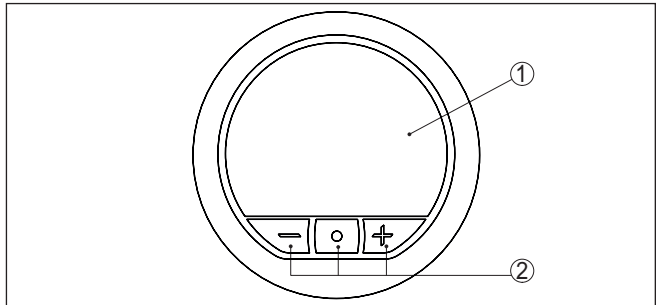

Fig. 22: Integrated display and adjustment unit

- 1 LC display
2 Adjustment keys

Key functions

Key	Function
[*]	Entry to the menu level Jump to selected menu item Edit parameter Select editing position Save value
[+]	Switching between the individual measured value windows Navigation in the menu items, forwards Change parameter values upwards
[-]	Switching between the individual measured value windows Navigation in the menu items, backwards Change parameter values downwards
[+] and [-] simultaneously	Jump to next higher menu Interrupt input

Time functions

When the **[+]** and **[-]** keys are pressed quickly, the edited value, or the cursor, changes one value or position at a time. If the key is pressed longer than 1 s, the value or position changes continuously.

Simultaneous pressing of the **[+]** and **[-]** keys causes a return to the measured value window.

Approx. 60 minutes after the last pressing of a key, an automatic reset to measured value indication is triggered. Any values not confirmed with **[O]** will not be saved.

Measured value indication

7.2 Measured value and menu item display

Measured value images are displayed according to the following presentation:

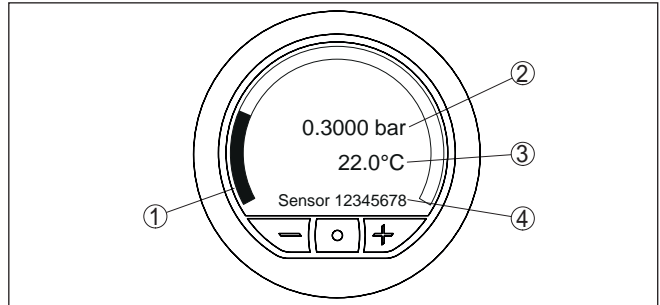

Fig. 23: Indication of measured value with additional displays

- 1 Measured value as bar graph
- 2 Measured value as digital value with unit
- 3 Measuring cell temperature
- 4 Sensor-TAG

Menu item display

The menu items are displayed according to the following diagram:

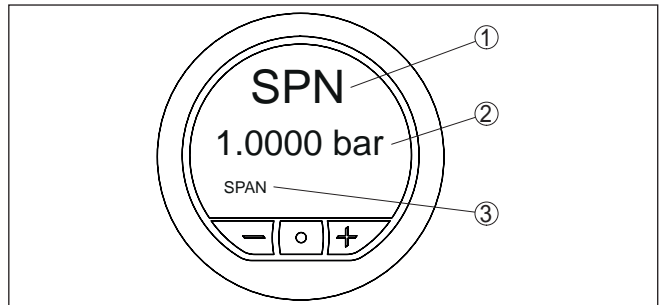

Fig. 24: Display menu item

- 1 Menu item code acc. to VDMA 24574-1
- 2 Actual parameter value
- 3 Menu item name

7.3 Menu overview

Main menu

Menu item	Code acc. to VDMA 24574-1	Basic settings
Zero 4 mA	ZEO	Measuring range begin
Span 20 mA	SPN	Measuring range end
Extended functions	EF	-
Diagnostics	DIA	-

Extended functions

Menu item	Code acc. to VDMA 24574-1	Basic settings
Damping	DAM	1 s
Offset correction	OFS	-
Reaction when malfunctions occur	FER	≤ 3.6 mA
Accept value 4 mA	LRV	-
Accept value 20 mA	URV	-
Display lighting	DIS	On
Pressure unit	UNI	mbar
Unit temperature	TMP	°C
Menu language	LG	English
Bluetooth access code	BT	On
Protection of the parameterization	COD	Off
Reset	RES	-

Diagnostics

Menu item	Code acc. to VDMA 24574-1	Delivery status
Status	STA	-
Parameter modification counter	PCO	-
Min. value pointer function	LO	Last values
Max. value pointer function	HI	
Sensor information	INF, HW, SW	-
Simulation	SIM	-

The menu items are described below and comply with the technical regulation VDMA 24574-1.

7.4 Parameter adjustment

7.4.1 Main menu

Selection language

With the first setup, the instrument offers you a selection of the menu languages. The selection you are making here can be changed any time under "*Extended functions*", "*Menu language*".

Zero

The menu item Zero (initial value) defines the pressure value at the output current 4 mA.



Information:

The zero adjustment has no influence on the value of the span adjustment.

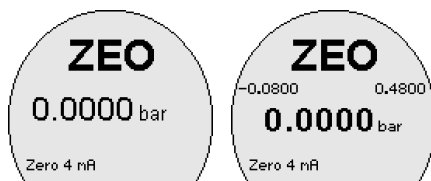

Menu item code:

- ZEO

Parameter:

- Pressure value

Span

The menu item Span (final value) defines the pressure value at the output current 20 mA.

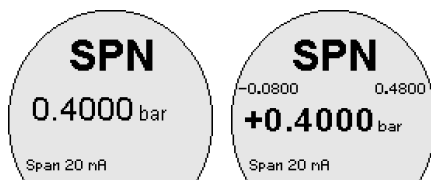

Menu item code:

- SPN

Parameter:

- Pressure value

Extended functions, diagnosis

These menu items allow access to the menu areas "*Extended functions*" or "*Diagnosis*".

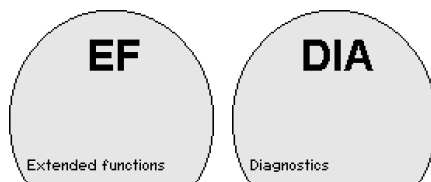

Menu item code:

- EF
- DIA

7.4.2 Extended functions

Reaction when malfunction occurs

In this menu item you define the behaviour of the current output in the event of failures.

Menu item code:

- FER

Parameter:

- ≤ 3.6 mA
- ≥ 21 mA

Damping

To damp process-dependent measured value fluctuations, set an integration time in this menu item.

Due to the set damping, the 4 ... 20 mA output as well as the switching output react in case of a sudden increased of the measured variable with a time-delayed slope curve.

Menu item code:

- DAM

Parameter:

- Time value

Offset correction

The installation position of the device can shift the measured value minimally (offset). The offset correction compensates this measured value shift. The measured value that should currently be displayed is entered (manual offset correction). With relative pressure transmitters, an automatic offset to 0.0000 bar can alternatively be carried out.



Note:

With automatic offset correction, the current measured value must not be influenced by product coverage or static pressure.

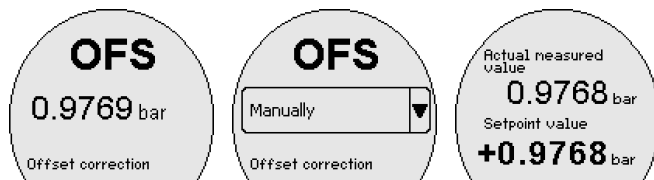

The position correction can be repeated as often as necessary. However, if the sum of the corrective values exceeds 20 % of the nominal measuring range, then no position correction is possible.

Menu item code:

- OFS

Parameter:

- Pressure value

Accept value

In this menu item (live adjustment) you can accept the current measured value as the value for the 4 mA adjustment (LRV) or the 20 mA adjustment (URV).¹⁾



Menu item code:

- LRV
- URV

Parameter:

- Pressure value

Display lighting

In this menu item you switch the background lighting for the display off or on.

Menu item code:

- DIS

Parameter

- On
- Off

Pressure unit

In this menu item the adjustment unit of the device is defined. The selection made determines the displayed unit in the menu items "Zero/ Span" and "Offset correction" as well as "Accept value".



Menu item code:

- UNI

¹⁾ LRV: Lower Range Value, URV: Upper Range Value

The following units are available: mbar, bar, psi, Pa, kPa, MPa, inHg, mmHg, mmH₂O, inH₂O

Unit temperature

In this menu item the temperature unit of the device is defined. The selection made determines the unit for the measuring cell temperature shown on the display.

Menu item code:

- TMP

Parameter:

- °C
- °F

Menu language

This menu item enables the setting of the requested national language for the display.

Menu item code:

- LG

The following languages are available: German, English, Spanish, French, Chinese, Japanese, Portuguese, Dutch, Italian, Russian.

Bluetooth access code

In this menu item, you can change the factory-preset Bluetooth access code to your personal Bluetooth access code.



Note:

The individual preset Bluetooth access code of the device can be found on the supplied information sheet "*PINs and Codes*". If this is changed by the user and is no longer available, access is only possible via the emergency Bluetooth unlock code on the information sheet "*Emergency unlock codes*" also supplied.

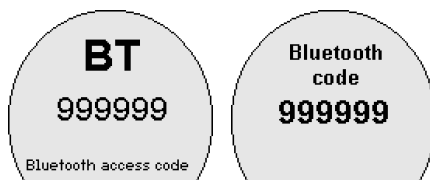

Menu item code:

- BT

Protection of the parameterization

In this menu item you safeguard the sensor parameters by entering a 6-digit device code against unauthorized or unintentional modifications.



With protected parameter adjustment, the individual menu items can be selected and displayed, however the parameters can no longer be modified.

The sensor operation can also be enabled in any menu item by entering the device code. The parameter adjustment remains open until you return to the measured value display. This takes place automatically after 60 min.

Menu item code:

- COD

Parameter:

- Numerical value



Note:

The factory set device code is "000000". If this is changed by the user and is no longer available, access is only possible via the emergency device unlock code on the information sheet "Emergency unlock codes" also supplied.



Note:

With protected parameter adjustment, adjustment via the VEGA Tools app as well as PACTware/DTM and other systems is also blocked.

Reset

During a reset, parameter settings made by the user are reset to the values of the basic setting or the delivery status (see chapter "Menu overview")²⁾.

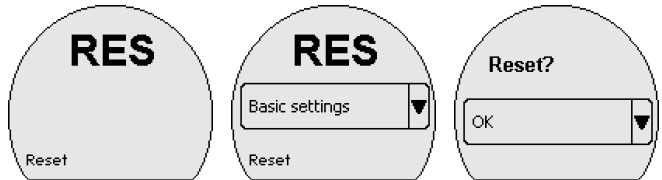

Menu item code:

- RES

Parameter:

- Basic settings
- Delivery status³⁾

Basic settings: Resets the parameter settings to the default values of the respective device. The order-related settings are not transferred to the current parameters after this reset.

Delivery status: Resets the parameter settings to the delivery status.



Information:

The current status of the access protection, the Bluetooth access code and the device code are not reset.

²⁾ Language and Bluetooth access code are not reset.

³⁾ Parameter delivery status only available with a parameter adjustment that deviates from the basic settings, e.g. customer-specific adjustment

7.4.3 Diagnostics

Status

In this menu item, the device status is displayed.



Menu item code:

- STA

In the event of an error, the error code, e.g. F017, and an error description, e.g. "Adjustment span too small" are displayed.

Parameter modification counter

This menu item displays the number of parameter changes made.

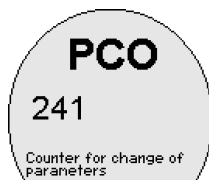

Menu item code:

- PCO

Peak value indicator

In this menu item, the min. and max. values for pressure, measuring cell temperature and electronics temperature are displayed.

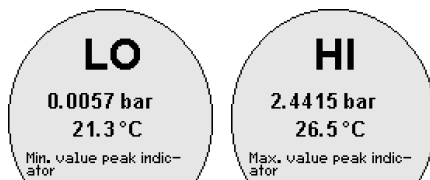

Menu item code:

- LO
- HI



Information:

To reset the pointer function, the VEGA Tools app or PACTware/DTM is required.

Sensor information

This menu item displays the hardware and software status as well as the serial number of the device.

Menu item code:

- INF

Parameter:

- HW
- SW
- SN

Extended functions - Simulation

In this menu item you simulate switching states of the transistor outputs or current values of the 4 ... 20 mA output. This allows the signal path to be tested, e.g. via downstream display instruments or the input card of the control system. The simulation values are: Pressure, current, switching status.

Menu item code:

- SIM

Parameter:

- Numerical value
- Open
- Closed



Note:

Without manual deactivation, the sensor terminates the simulation automatically after 60 minutes.

8 Setup with smartphone/tablet (Bluetooth)

8.1 Preparations

System requirements

Make sure that your smartphone/tablet meets the following system requirements:

- Operating system: iOS 8 or newer
- Operating system: Android 4.3 or newer
- Bluetooth 4.0 LE or newer

Download the VEGA Tools app from the "Apple App Store", "Google Play Store" or "Baidu Store" to your smartphone or tablet.

8.2 Connecting

Connecting ...

Start the VEGA Tools app and select the function "Setup". The smartphone/tablet searches automatically for Bluetooth-capable instruments in the area.

The message "Searching ..." is displayed.

The devices found are listed and the search is automatically continued continuously.

Select the requested instrument in the device list.

Authenticate

For the first connection, the operating device and the sensor must authenticate each other. After successful authentication, the next connection functions without authentication.

iOS

During the pairing process, the following message is displayed: "Pairing request (Bluetooth), e.g. 12345678 wants to pair with your iPad/iPhone". Press "Pair".

Android

The coupling passes through automatically.

Enter Bluetooth access code

For authentication, enter the 6-digit Bluetooth access code in the next menu window or scan it via the bar code (DataMatrix). You can find the code on the outside of the device housing and on the information sheet "PINs and Codes" in the device packaging.

For the very first connection, the adjustment unit and the sensor must authenticate each other.



Enter the 6 digit Bluetooth access code of your Bluetooth instrument.

Fig. 25: Enter Bluetooth access code



Note:

If an incorrect code is entered, the code can only be entered again after a delay time. This time gets longer after each incorrect entry.

The message "Waiting for authentication" is displayed on the smartphone/tablet.

Connected

After connection, the sensor adjustment menu is displayed on the respective adjustment instrument.

If the Bluetooth connection is interrupted, e.g. due to a too large distance between the two devices, this is displayed on the operating device. The message disappears when the connection is restored.

Change device code

Parameter adjustment of the device is only possible if the parameter protection is deactivated. When delivered, parameter protection is deactivated by default and can be activated at any time.

It is recommended to enter a personal 6-digit device code. To do this, go to menu "Extended functions", "Access protection", menu item "Protection of the parameter adjustment".

Enter parameters

8.3 Sensor parameter adjustment

The sensor adjustment menu is divided into two halves:

On the left you'll find the navigation section with the menus "Setup", "Display", "Diagnosis" and others.

The selected menu item, recognisable by the colour change, is displayed in the right half.

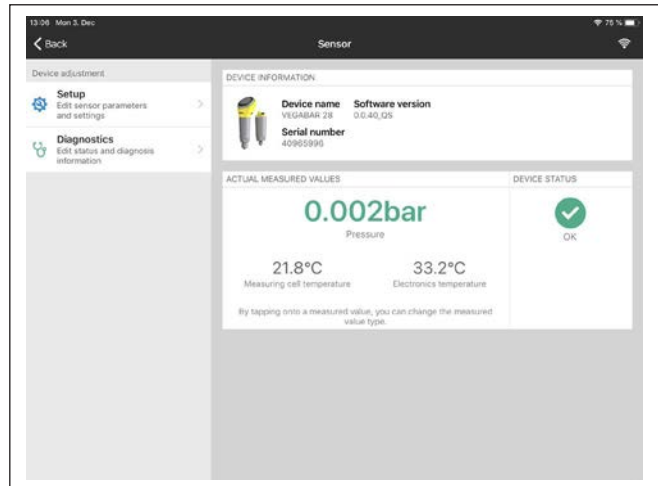

Fig. 26: Example of an app view - Setup sensor adjustment

9 Setup with PC/notebook (Bluetooth)

9.1 Preparations

System requirements

Make sure that your PC/notebook meets the following system requirements:

- Operating system Windows 10
- DTM Collection 12/2019 or newer
- Bluetooth 4.0 LE or newer

Activate Bluetooth connection



Activate the Bluetooth connection via the VEGA project assistant.

Note:

Older systems do not always have an integrated Bluetooth LE. In these cases, a Bluetooth USB adapter is required.

Activate the Bluetooth USB adapter via the VEGA project assistant (see supplementary instructions "*Bluetooth USB adapter*").

After activating the integrated Bluetooth or the Bluetooth USB adapter, devices with Bluetooth are found and created in the project tree.

9.2 Connecting

Connecting ...

Select the requested sensor for the online parameter adjustment in the project tree.

Authenticate

The window "*Authentication*" is displayed. For the first connection, the operating device and the sensor must authenticate each other. After successful authentication, the next connection functions without authentication.

Enter Bluetooth access code

For authentication, enter in the next menu window the 6-digit Bluetooth access code:

Fig. 27: Enter Bluetooth access code

You can find the code on the outside of the device housing and on the information sheet "*PINs and Codes*" in the device packaging.



Note:

If an incorrect code is entered, the code can only be entered again after a delay time. This time gets longer after each incorrect entry.

The message "Waiting for authentication" is displayed on the PC/notebook.

Connected

After connection, the sensor DTM appears.

If the connection is interrupted, e.g. due to a too large distance between sensor and operating device, this is displayed on the operating device. The message disappears when the connection is restored.

Change device code

Parameter adjustment of the device is only possible if the parameter protection is deactivated. When delivered, parameter protection is deactivated by default and can be activated at any time.

It is recommended to enter a personal 6-digit device code. To do this, go to menu "Extended functions", "Access protection", menu item "Protection of the parameter adjustment".

9.3 Parameter adjustment

Prerequisites

For parameter adjustment of the instrument via a Windows PC, the configuration software PACTware and a suitable instrument driver (DTM) according to FDT standard are required. The latest PACTware version as well as all available DTMs are compiled in a DTM Collection. The DTMs can also be integrated into other frame applications according to FDT standard.

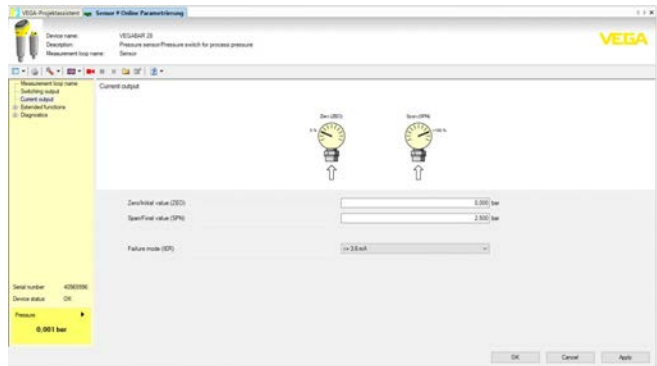

Fig. 28: Example of a DTM view - Adjustment current output

10 Diagnostics and servicing

10.1 Maintenance

Maintenance

If the device is used properly, no special maintenance is required in normal operation.

Precaution measures against buildup

In some applications, product buildup on the diaphragm can influence the measuring result. Depending on the sensor and application, take precautions to ensure that heavy buildup, and especially a hardening thereof, is avoided.

Cleaning

The cleaning helps that the type label and markings on the instrument are visible.

Take note of the following:

- Use only cleaning agents which do not corrode the housings, type label and seals
- Use only cleaning methods corresponding to the housing protection rating

10.2 Rectify faults

Reaction when malfunction occurs

The operator of the system is responsible for taking suitable measures to rectify faults.

Causes of malfunction

The device offers maximum reliability. Nevertheless, faults can occur during operation. These may be caused by the following, e.g.:

- Sensor
- Process
- Voltage supply
- Signal processing

Fault rectification

The first measures are:

- Evaluation of fault messages
- Checking the output signal
- Treatment of measurement errors

A smartphone/tablet with the VEGA Tools app or a PC/notebook with the software PACTware and the suitable DTM offer you further comprehensive diagnostic possibilities. In many cases, the causes can be determined in this way and the faults eliminated.

Reaction after fault rectification

Depending on the reason for the fault and the measures taken, the steps described in chapter "Setup" must be carried out again or must be checked for plausibility and completeness.

24 hour service hotline

Should these measures not be successful, please call in urgent cases the VEGA service hotline under the phone no. **+49 1805 858550**.

The hotline is also available outside normal working hours, seven days a week around the clock.

Since we offer this service worldwide, the support is provided in English. The service itself is free of charge, the only costs involved are the normal call charges.

10.3 Diagnosis, fault messages

4 ... 20 mA signal

Connect a multimeter in the suitable measuring range according to the wiring plan. The following table describes possible errors in the current signal and helps to eliminate them:

Error	Cause	Rectification
4 ... 20 mA signal not stable	Fluctuating measured value	Set damping
4 ... 20 mA signal missing	Electrical connection faulty	Check connection, correct, if necessary
	Voltage supply missing	Check cables for breaks; repair if necessary
	Operating voltage too low, load resistance too high	Check, adapt if necessary
Current signal greater than 22 mA, less than 3.6 mA	Sensor electronics defective	Replace device or send in for repair depending on device version

10.4 Status messages according to NE 107

The instrument features self-monitoring and diagnostics according to NE 107 and VDI/VDE 2650. In addition to the status messages in the following tables there are more detailed error messages available under the menu item "Diagnostics" via the respective adjustment module.

Status messages

The status messages are divided into the following categories:

- Failure
- Function check
- Out of specification
- Maintenance requirement

and explained by pictographs:

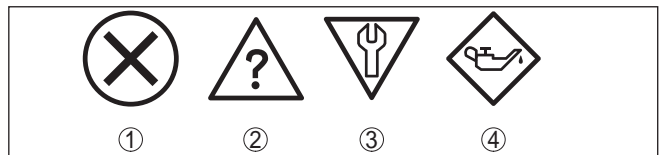

Fig. 29: Pictographs of the status messages

- 1 Failure - red
- 2 Out of specification - yellow
- 3 Function check - orange
- 4 Maintenance - blue

Failure: Due to a malfunction in the instrument, a fault message is output.

This status message is always active. It cannot be deactivated by the user.

Function check: The instrument is being worked on, the measured value is temporarily invalid (for example during simulation).

This status message is inactive by default.

Out of specification: The measured value is unreliable because an instrument specification was exceeded (e.g. electronics temperature).

This status message is inactive by default.

Maintenance: Due to external influences, the instrument function is limited. The measurement is affected, but the measured value is still valid. Plan in maintenance for the instrument because a failure is expected in the near future (e.g. due to buildup).

This status message is inactive by default.

Failure

Code Text message	Cause	Rectification
F013 no measured value available	Hardware error in the area of the measuring cell	Send instrument for repair
F017 Adjustment span too small	Adjustment not within specification	Change adjustment
F036 no operable sensor software	Failed or interrupted software update	Repeat software update
F080 General software error	General software error	Restart
F110 Switching points too close together	Selected switching points too close together	Increase the distance between the switching points
F111 Switching points interchanged	Switching point 1 is smaller than switching point 2	Increase switching point 1 to greater than switching point 2
F260 Error in the calibration	Checksum error in the calibration values	Send instrument for repair
F261 Error in the instrument settings	Checksum error in the configuration values	Carry out a reset

Function check

Code Text message	Cause	Rectification
C700 Simulation active	A simulation is active	Finish simulation Wait for the automatic end after 60 mins.

Out of specification

Code Text message	Cause	Rectification
S600 Impermissible electronics temperature	Temperature of the electronics in the non-specified range	Check ambient temperature Insulate electronics
S604 Switching output overloaded	Overload or short circuit at output 1 or 2	Electrical connection, check load resistance

Maintenance

Code Text message	Cause	Rectification
M504 Error at a device interface	Interference of the internal communication to Bluetooth	Restart Send instrument for repair
M510 No communication with the main controller	Fault in internal communication with the display	Restart Send instrument for repair

10.5 Software update

The device software is updated via Bluetooth.

The following components are required:

- Instrument
- Voltage supply
- PC/notebook with PACTware/DTM and Bluetooth USB adapter
- Current instrument software as file

You can find the current instrument software as well as detailed information on the procedure in the download area of our homepage.



Caution:

Instruments with approvals can be bound to certain software versions. Therefore make sure that the approval is still effective after a software update is carried out.

You can find detailed information in the download area on our homepage.

10.6 How to proceed if a repair is necessary

You can find an instrument return form as well as detailed information about the procedure in the download area of our homepage. By doing this you help us carry out the repair quickly and without having to call back for needed information.

In case of repair, proceed as follows:

- Print and fill out one form per instrument
- Clean the instrument and pack it damage-proof
- Attach the completed form and, if need be, also a safety data sheet outside on the packaging

- Ask the agency serving you to get the address for the return shipment. You can find the agency on our homepage.

11 Dismount

11.1 Dismounting steps

**Warning:**

Before dismantling, be aware of dangerous process conditions such as e.g. pressure in the vessel or pipeline, high temperatures, corrosive or toxic media etc.

Take note of chapters "*Mounting*" and "*Connecting to voltage supply*" and carry out the listed steps in reverse order.

11.2 Disposal

The device is made of recyclable materials. For this reason, it should be disposed of by a specialist recycling company. Observe the applicable national regulations.

12 Certificates and approvals

12.1 Environmental instructions

Objective and measures

Protection of the environment is one of our most important duties. That is why we have introduced an environment management system with the goal of continuously improving company environmental protection. The environment management system is certified according to DIN EN ISO 14001.

Please help us fulfil this obligation by observing the environmental instructions in this manual:

- Chapter "*Packaging, transport and storage*"
- Chapter "*Disposal*"

13 Supplement

13.1 Technical data

Note for approved instruments

The technical data in the respective safety instructions which are included in delivery are valid for approved instruments (e.g. with Ex approval). These data can differ from the data listed herein, for example regarding the process conditions or the voltage supply.

All approval documents can be downloaded from our homepage.

Materials and weights

Materials, wetted parts

Process fitting	316L, PVDF, Duplex steel (1.4462)
Diaphragm	Sapphire-ceramic® (> 99.9 % Al ₂ O ₃ ceramic)
Measuring cell seal	FKM (VP2/A), EPDM (A+P 70.10-02), FFKM (Perlast G75S)

Seal for process fitting (in the scope of delivery)

- Thread G $\frac{1}{4}$ (EN 837), G $\frac{3}{4}$ (ISO 228-1), G1 (DIN 3852-E) Klingersil C-4400
- Thread M30 x 1.5 FKM, EPDM, FFKM

Materials for applications in foodstuffs

Surface quality, hygienic fittings, typ.

- Process fitting R_a < 0.8 µm
- Ceramic diaphragm R_a < 0.5 µm

Materials, non-wetted parts

Electronics housing	316L, PBT/PC
Illuminated ring	PC
M12 x 1 plug connector	
- Contact support	PBT/PC
- Contacts	CuZn, nickel layer and 0.8 µm gold-plated
Weight	approx. 0.25 kg (0.55 lbs)

Torques

Max. torque for process fitting (examples)

- Clamp 5/10 Nm (3.688/7.376 lbf ft)
- Varivent 20 Nm (14.75 lbf ft)
- Thread G $\frac{1}{2}$ (ISO 228-1), G $\frac{3}{4}$ (DIN 3852-E), M30 x 1.5, Ingold, NPT connections 30 Nm (22.13 lbf ft)
- SMS, collar socket DIN 11851, DIN 11864-1, Form A 40 Nm (29.50 lbf ft)
- Thread G $\frac{1}{2}$ (EN 837), G1 (ISO 228-1), G1 $\frac{1}{2}$ (DIN 3852-A) 50 Nm (36.88 lbf ft)
- Thread G1 with conus 100 Nm (73.76 lbf ft)

Input variable

The specifications are only an overview and refer to the measuring cell. Limitations due to the material and version of the process fitting as well as the selected pressure type are possible. The specifications on the nameplate apply.⁴⁾

Nominal measuring ranges and overload capability in bar/kPa

Nominal range	Overload capacity, max. pressure	Overload capacity, min. pressure
Gauge pressure		
0 ... +0.1 bar/0 ... +10 kPa	+15 bar/+1500 kPa	-0.2 bar/-20 kPa
0 ... +0.4 bar/0 ... +40 kPa	+30 bar/+3000 kPa	-0.8 bar/-80 kPa
0 ... +1 bar/0 ... +100 kPa	+35 bar/+3500 kPa	-1 bar/-100 kPa
0 ... +2.5 bar/0 ... +250 kPa	+50 bar/+5000 kPa	-1 bar/-100 kPa
0 ... +5 bar/0 ... +500 kPa	+65 bar/+6500 kPa	-1 bar/-100 kPa
0 ... +10 bar/0 ... +1000 kPa	+90 bar/+9000 kPa	-1 bar/-100 kPa
0 ... +25 bar/0 ... +2500 kPa	+130 bar/+13000 kPa	-1 bar/-100 kPa
0 ... +60 bar/0 ... +6000 kPa	+200 bar/+20000 kPa	-1 bar/-100 kPa
-0.05 ... +0.05 bar/-5 ... +5 kPa	+15 bar/+1500 kPa	-0.2 bar/-20 kPa
-0.2 ... +0.2 bar/-20 ... +20 kPa	+20 bar/+2000 kPa	-0.4 bar/-40 kPa
-0.5 ... +0.5 bar/-50 ... +50 kPa	+35 bar/+3500 kPa	-1 bar/-100 kPa
-1 ... 0 bar/-100 ... 0 kPa	+35 bar/+3500 kPa	-1 bar/-100 kPa
-1 ... +1.5 bar/-100 ... +150 kPa	+40 bar/+4000 kPa	-1 bar/-100 kPa
Absolute pressure		
0 ... 1 bar/0 ... 100 kPa	35 bar/3500 kPa	0 bar abs.
0 ... 2.5 bar/0 ... 250 kPa	50 bar/5000 kPa	0 bar abs.
0 ... +5 bar/0 ... +500 kPa	65 bar/+6500 kPa	0 bar abs.
0 ... 10 bar/0 ... 1000 kPa	90 bar/9000 kPa	0 bar abs.
0 ... 25 bar/0 ... 2500 kPa	+130 bar/+13000 kPa	0 bar abs.
0 ... 60 bar/0 ... 6000 kPa	+200 bar/+20000 kPa	0 bar abs.

Nominal measuring ranges and overload capacity in psi

Nominal range	Overload capacity, max. pressure	Overload capacity, min. pressure
Gauge pressure		
0 ... +1.5 psig	+225 psig	-3 psig
0 ... +5 psig	+435 psig	-12 psig
0 ... +15 psig	+525 psig	-14.51 psig
0 ... +30 psig	+725 psig	-14.51 psig
0 ... +75 psig	+950 psig	-14.51 psig
0 ... +150 psig	+1300 psig	-14.51 psig

⁴⁾ Data on overload capability apply for reference temperature.

Nominal range	Overload capacity, max. pressure	Overload capacity, min. pressure
0 ... +300 psig	+1900 psig	-14.51 psig
0 ... +900 psig	+2900 psig	-14.51 psig
-0.7 ... +0.7 psig	+225 psig	-3 psig
-3 ... +3 psig	+290 psi	-6 psig
-7 ... +7 psig	+525 psig	-14.51 psig
-14.5 ... 0 psig	+525 psig	-14.51 psig
-14.5 ... +20 psig	+580 psig	-14.51 psig
Absolute pressure		
0 ... 15 psi	525 psi	0 psi
0 ... 30 psi	600 psi	0 psi
0 ... +75 psi	975 psi	0 psi
0 ... 150 psi	1350 psi	0 psi
0 ... 300 psi	1500 psi	0 psi
0 ... 900 psi	+2900 psi	0 psi

Adjustment ranges

Specifications refer to the nominal measuring range, pressure values lower than -1 bar cannot be set

Zero/Span adjustment:

- Zero -20 ... +95 %
- Span -120 ... +120 %

Maximum permissible Turn Down Unlimited (recommended 20 : 1)

Switch-on phase

Run-up time with operating voltage U_B ≤ 2 s

Starting current for run-up time ≤ 3.6 mA

Output variable - two-wire 4 ... 20 mA

Output signal 4 ... 20 mA - passive

Connection technology Two-wire

Range of the output signal 3.8 ... 20.5 mA

Signal resolution 5 μ A

Fault signal, current output (adjustable) ≤ 3.6 mA, ≥ 21 mA, last measured value

Max. output current 21.5 mA

Load See load resistance under Power supply

Damping (63 % of the input variable), adjustable 0 ... 999 s

Transferred measured value Pressure

Dynamic behaviour output

Dynamic characteristics - Current output

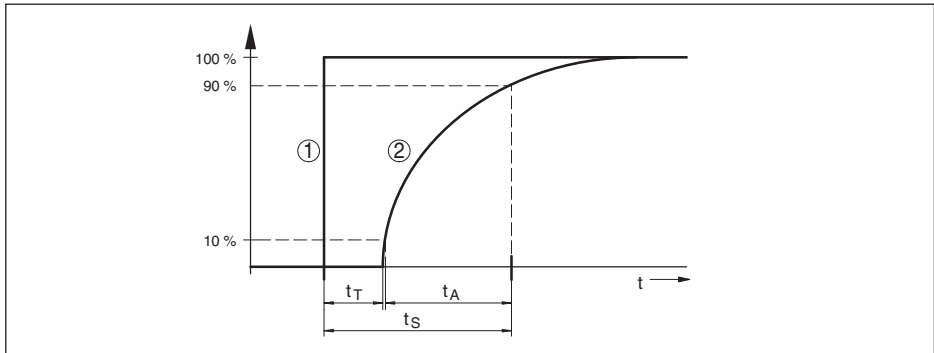

Fig. 30: Behaviour the current output in case of sudden change of the process variable. t_T : dead time; t_A : rise time; t_S : jump response time

- 1 Process variable
2 Output signal

Size	Time
Dead time	≤ 4 ms
Rise time (10 ... 90 %)	≤ 2 ms
Step response time (ti: 0 s, 10 ... 90 %)	≤ 4 ms

Damping (63 % of the input variable) 0 ... 9 s, adjustable

Reference conditions and influencing variables (according to DIN EN 60770-1)

Reference conditions according to DIN EN 61298-1

- Temperature +15 ... +25 °C (+59 ... +77 °F)
- Relative humidity 45 ... 75 %
- Air pressure 860 ... 1060 mbar/86 ... 106 kPa (12.5 ... 15.4 psig)

Determination of characteristics Limit point adjustment according to IEC 61298-2

Characteristic curve Linear

Reference installation position upright, diaphragm points downward

Influence of the installation position < 0.2 mbar/20 Pa (0.003 psig)

Deviation (according to IEC 60770)

Applies to the 4 ... 20 mA current output and refers to the adjusted span. Turn down (TD) is the relation nominal measuring range/adjusted span.

Accuracy class	Non-linearity, hysteresis and repeatability with TD 1 : 1 up to 5 : 1	Non-linearity, hysteresis and repeatability with 5 : 1
0.3 %	< 0.3 %	< 0.06 % x TD

Influence of the medium or ambient temperature

Average temperature coefficient of the zero signal⁵⁾ < 0.15 %/10 K

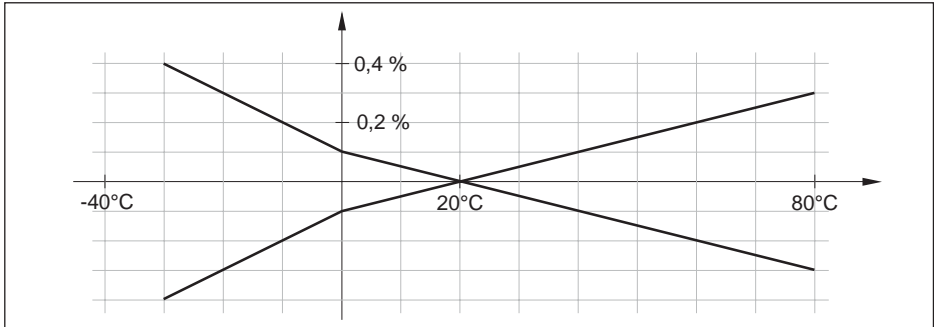

Fig. 31: Temperature error with TD 1 : 1

Long-term stability (according to DIN 16086)

Specifications refer to the set span. Turn down (TD) is the ratio: nominal measuring range/set span.

Time period	Long-term drift zero signal and output span
One year	< 0.1 % x TD
Two years	< 0.15 % x TD
Five years	< 0.2 % x TD
Ten years	< 0.4 % x TD

Ambient conditions

Ambient temperature device	-40 ... +80 °C (-40 ... +176 °F)
Ambient temperature display	-25 ... +80 °C (-13 ... +176 °F)
Storage and transport temperature ⁶⁾	-40 ... +80 °C (-40 ... +176 °F)

Mechanical environmental conditions

Sinusoidal vibrations	Class 4M8 acc. to IEC 60271-3-4
Impacts	50 g, 2.3 ms according to EN 60068-2-27 (mechanical shock)
Impact resistance	
– Plug according to ISO 4400	IK07 acc. to IEC 62262
– M12 x 1 plug	IK06 acc. to IEC 62262

Process conditions

Process temperature

⁵⁾ In the compensated temperature range 0 ... +100 °C (+32 ... +212 °F).

⁶⁾ Relative humidity 20 ... 85 %

Measuring cell seal		Process temperature	Process temperature with process fitting PVDF
FKM	VP2/A	-20 ... +130 °C (-4 ... +266 °F)	-20 ... +80 °C (-4 ... +176 °F) ⁷⁾
EPDM	A+P 70.10-02	-40 ... +130 °C (-40 ... +266 °F)	
FFKM	Perlast G75S	-15 ... +130 °C (+5 ... +266 °F)	

Temperature derating

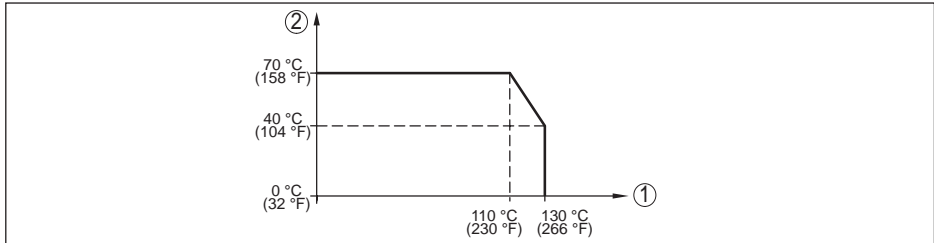

Fig. 32: Temperature derating VEGABAR 38

- 1 Process temperature
- 2 Ambient temperature

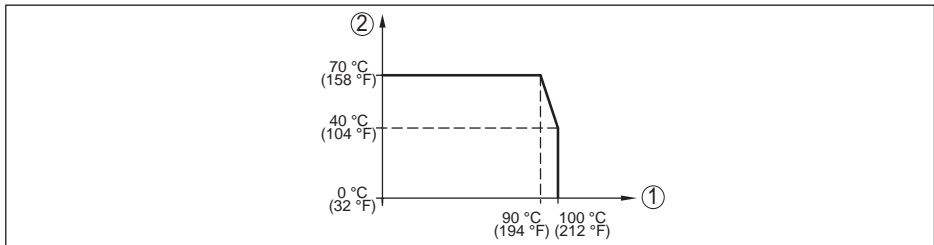

Fig. 33: Temperature derating VEGABAR 38, with activated Bluetooth communication

- 1 Process temperature
- 2 Ambient temperature

SIP process temperature (SIP = Sterilization in place)

Instrument configuration suitable for vapour i.e. measuring cell seal EPDM or FFKM (Perlast G75S).

Vapour stratification up to 1 h +135 °C (+275 °F)

Process pressure

Permissible process pressure see specification "MWP" on the type label⁸⁾

Indication

Measured value and menu display

- Graphic-capable LC display, with lighting digital and quasianalogue indication
- Max. indicating range -99999 ... 99999

⁷⁾ Process pressures > 5 bar: 20 ... +60 °C (-4 ... +140 °F)

⁸⁾ MWP: Maximum Working Pressure

Adjustment

Adjustment elements	3 x keys for menu adjustment
PC/Notebook	PACTware/DTM
Smartphone/Tablet	VEGA Tools-App

Bluetooth interface

Bluetooth standard	Bluetooth 5.0 (downward compatible to Bluetooth 4.0 LE)
Max. participants	1
Effective range ⁹⁾	max. 25 m (82 ft)

Electromechanical data

Angled plug connector

- Version 4-pin according to ISO 4400
- Cable gland M16 x 1.5 (for cable diameter 4.5 ... 7 mm)
- Screw terminals for cable cross-section up to 1.5 mm² (AWG 15)

Angle plug connector with flap lid

- Version 4-pin according to ISO 4400
- Cable gland M16 x 1.5 (for cable diameter 4.5 ... 11 mm)
- Screw terminals for cable cross-section up to 1.5 mm² (AWG 15)

Angled plug connector with IDC method of termination

- Version 4-pin according to ISO 4400
- Wire cross-section 0.5 ... 1 mm² (AWG 20... AWG 17)
- Strand diameter > 0.1 mm
- Wire diameter 1.6 ... 2 mm
- Outer cable diameter 5.5 ... 8 mm
- Connection frequency (on the same cross-section) 10 x

Round plug connector

4-pole with M12 x 1 screw connection

Voltage supply

Operating voltage U_B 12 ... 35 V DC

Operating voltage U_B - illuminated display and adjustment unit 15 ... 35 V DC

Reverse voltage protection Integrated

Permissible residual ripple

- for U_N 12 V DC ($12 \text{ V} < U_B < 18 \text{ V}$) $\leq 0.7 V_{\text{eff}}$ (16 ... 400 Hz)
- for U_N 24 V DC ($18 \text{ V} < U_B < 35 \text{ V}$) $\leq 1.0 V_{\text{eff}}$ (16 ... 400 Hz)

Load resistor

- Calculation $(U_B - U_{\text{min}})/0.022 \text{ A}$

⁹⁾ Depending on the local conditions

– Example - for $U_B = 24 \text{ V DC}$ $(24 \text{ V} - 12 \text{ V})/0.022 \text{ A} = 545 \Omega$

Electrical protective measures

Potential separation Electronics potential free up to 500 V AC

Protection rating

Connection technology	Protection according to EN 60529/IEC 529	Protection according to UL 50
M12 x 1 plug	IP66/IP67/69	Type 6P
Plug according to ISO 4400	IP65	Type 4X
ISO 4400 plug with hinged cover		

Altitude above sea level 5000 m (16404 ft)

Protection class III

Pollution degree 4

13.2 Dimensions

Connection technology

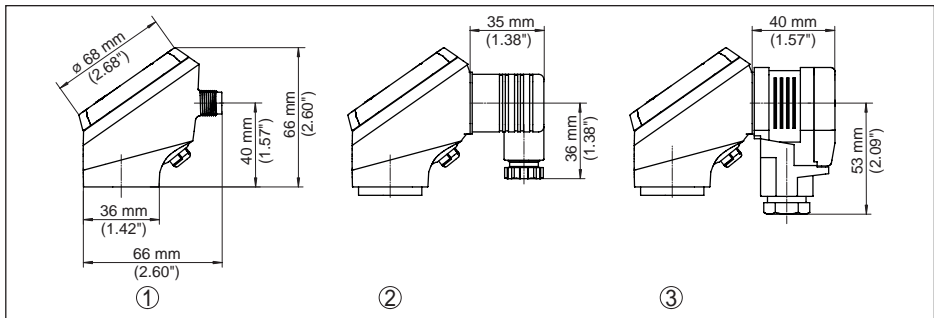

Fig. 34: Connection technology VEGABAR 38

- 1 M12 x 1 plug connector
- 2 Plug connector according to ISO 4400
- 3 Plug connector according to ISO 4400 with hinged cover

VEGABAR 38, threaded fitting not front-flush

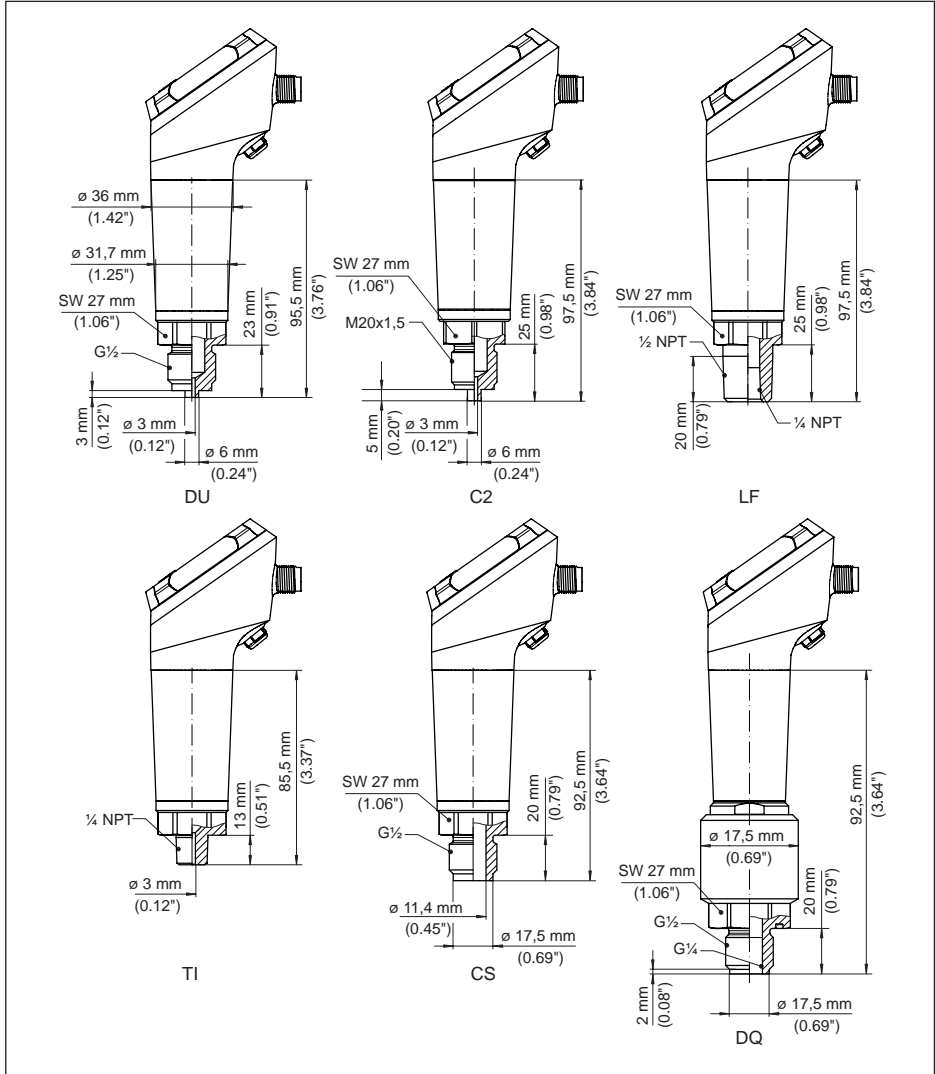

Fig. 35: VEGABAR 38, threaded fitting not front-flush

- DU Thread G 1/2 (EN 837), manometer connection
- C2 Thread M20 x 1.5 (EN 837), manometer connection
- LF Thread 1/2 NPT, inside 1/4 NPT (ASME B1.20.1)
- TI Thread 1/4 NPT (ASME B1.20.1)
- CS Thread G 1/2, inside G 1/4 (ISO 228-1), Duplex (1.4462)
- DQ Thread G 1/2, inside G 1/4 (ISO 228-1), PVDF

57088-EN-191014

VEGABAR 38, threaded fitting front-flush

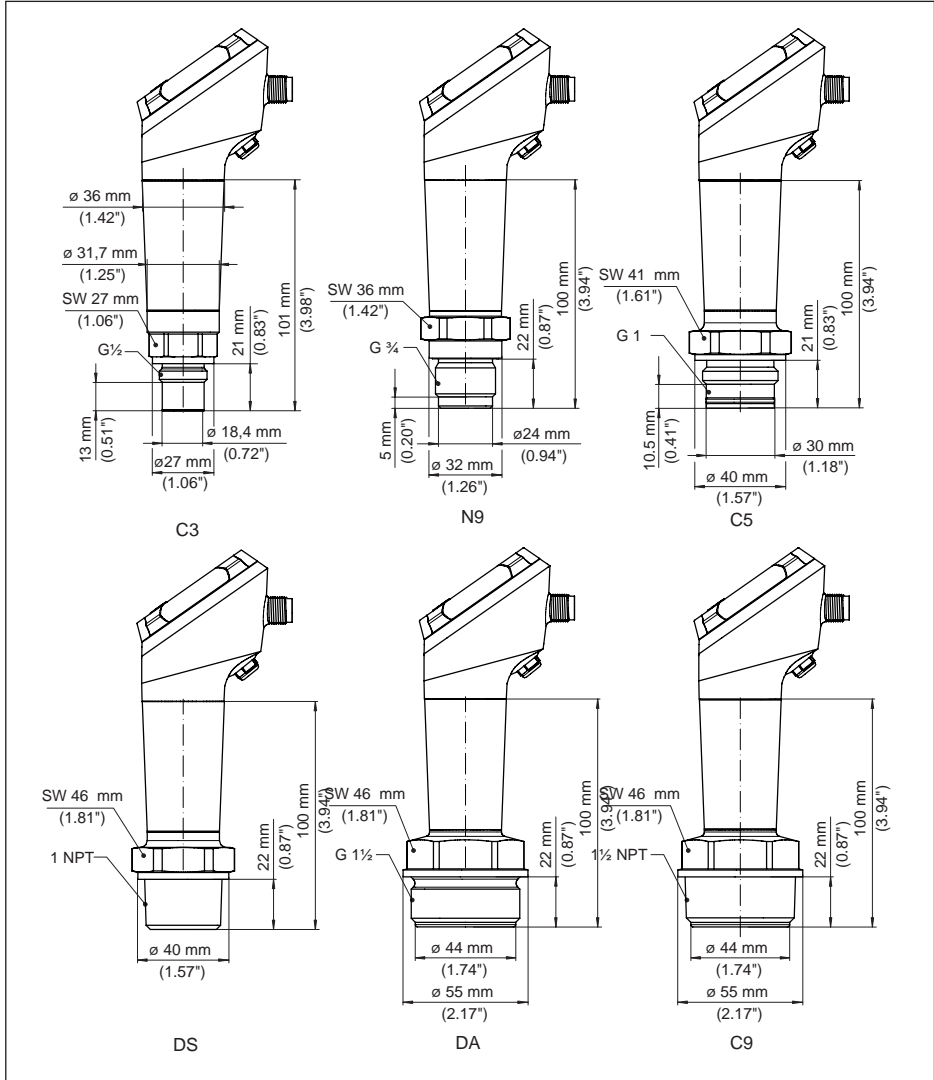

Fig. 36: VEGABAR 38, threaded fitting front-flush

C3 Thread G $\frac{1}{2}$ (ISO 228-1)N9 Thread G $\frac{3}{4}$ (DIN 3852-E)

C5 Thread G1 (ISO 228-1)

DS Thread 1 NPT (ASME B1.20.1)

DA Thread G $1\frac{1}{2}$ (DIN 3852-A)C9 Thread $1\frac{1}{2}$ NPT (ASME B1.20.1)

VEGABAR 38, threaded fitting front-flush with cone/extension

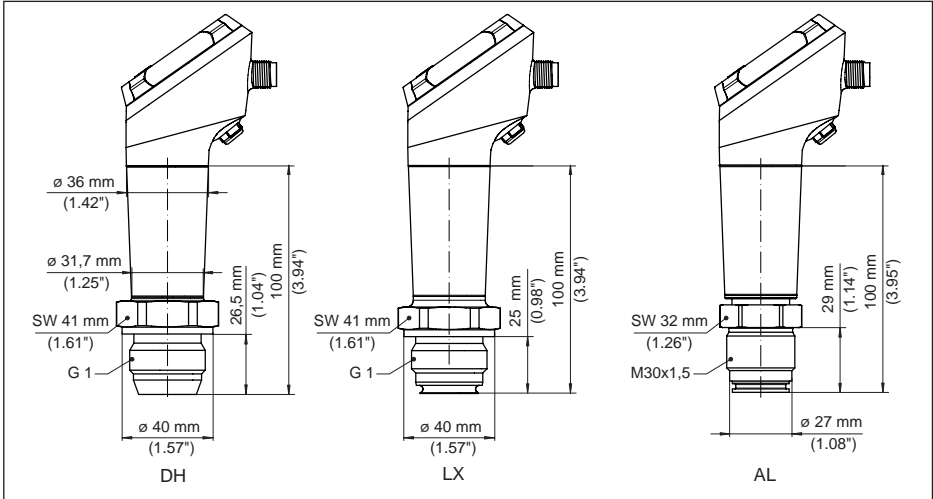

Fig. 37: VEGABAR 38, cone/extension fitting

DH Thread G1 (ISO 228-1), cone 40°

LX Thread G1 (ISO 228-1), hygienic design

AL Thread M30 x 1.5 (DIN 13)

VEGABAR 38, hygienic fitting

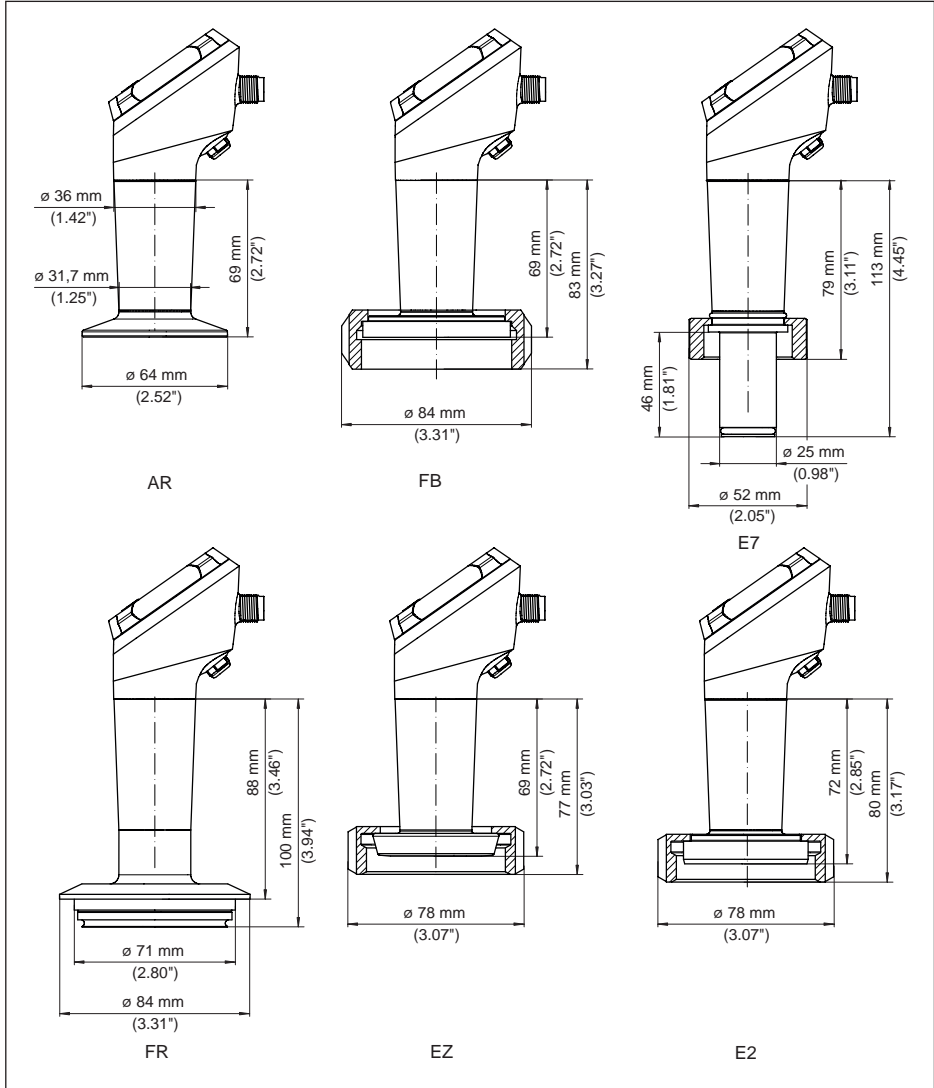

Fig. 38: VEGABAR 38, hygienic fitting

AR Clamp 2" PN 40 $\varnothing 64$ mm (DIN 32676, ISO 2852)

FB SMS DN51 PN6

E7 Ingold connection PN 10

FR Varivent N50-40 PN 25

EZ Collar socket DN 40 PN 40 (DIN 11851)

E2 Collar socket DN 40 PN 40 (DIN 11864-1, Form A)

13.3 Industrial property rights

VEGA product lines are global protected by industrial property rights. Further information see www.vega.com.

VEGA Produktfamilien sind weltweit geschützt durch gewerbliche Schutzrechte.

Nähere Informationen unter www.vega.com.

Les lignes de produits VEGA sont globalement protégées par des droits de propriété intellectuelle. Pour plus d'informations, on pourra se référer au site www.vega.com.

VEGA líneas de productos están protegidas por los derechos en el campo de la propiedad industrial. Para mayor información revise la página web www.vega.com.

Линии продукции фирмы ВЕГА защищаются по всему миру правами на интеллектуальную собственность. Дальнейшую информацию смотрите на сайте www.vega.com.

VEGA系列产品在全球享有知识产权保护。

进一步信息请参见网站www.vega.com。

13.4 Hash function acc. to mbed TLS

mbed TLS: Copyright (C) 2006-2015, ARM Limited, All Rights Reserved SPDX-License-Identifier: Apache-2.0

Licensed under the Apache License, Version 2.0 (the "License"); you may not use this file except in compliance with the License. You may obtain a copy of the License at <http://www.apache.org/licenses/LICENSE-2.0>.

Unless required by applicable law or agreed to in writing, software distributed under the License is distributed on an "AS IS" BASIS, WITHOUT WARRANTIES OR CONDITIONS OF ANY KIND, either express or implied. See the License for the specific language governing permissions and limitations under the License.

13.5 Trademark

All the brands as well as trade and company names used are property of their lawful proprietor/originator.

Printing date:

VEGA

All statements concerning scope of delivery, application, practical use and operating conditions of the sensors and processing systems correspond to the information available at the time of printing.

Subject to change without prior notice

© VEGA Grieshaber KG, Schiltach/Germany 2019



57088-EN-191014

VEGA Grieshaber KG
Am Hohenstein 113
77761 Schiltach
Germany

Phone +49 7836 50-0
Fax +49 7836 50-201
E-mail: info.de@vega.com
www.vega.com