

PSR-E

PS Automation 
Gesellschaft für Antriebstechnik

We care for actuation.

The strong quarter-turn actuator for up to 50 Nm

Pre-adjusted switching cams

The cams of the cut-off and position signalling switches are vibration-proof and pre-adjusted by PS Automation.



Comfortable manual override

due to „Push and Turn“. Automatic reengagement.

Reliable even under harsh conditions

Ideal for industrial environments: cover made of UV-resistant polycarbonate, degree of protection IP65.

Easily visible position indicator

shows the current position of the valve on a big scale with OPEN/CLOSE symbols.

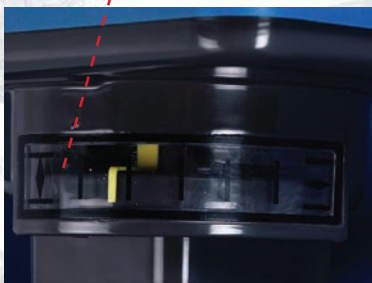

Robust gearbox
made from high quality aluminium.

Externally adjustable stop screw
prevents from manual overriding of the closed position.



Strong and efficient

maintenance-free, high-efficiency and low-noise spur gear resulting in low-wear and long lifetime.

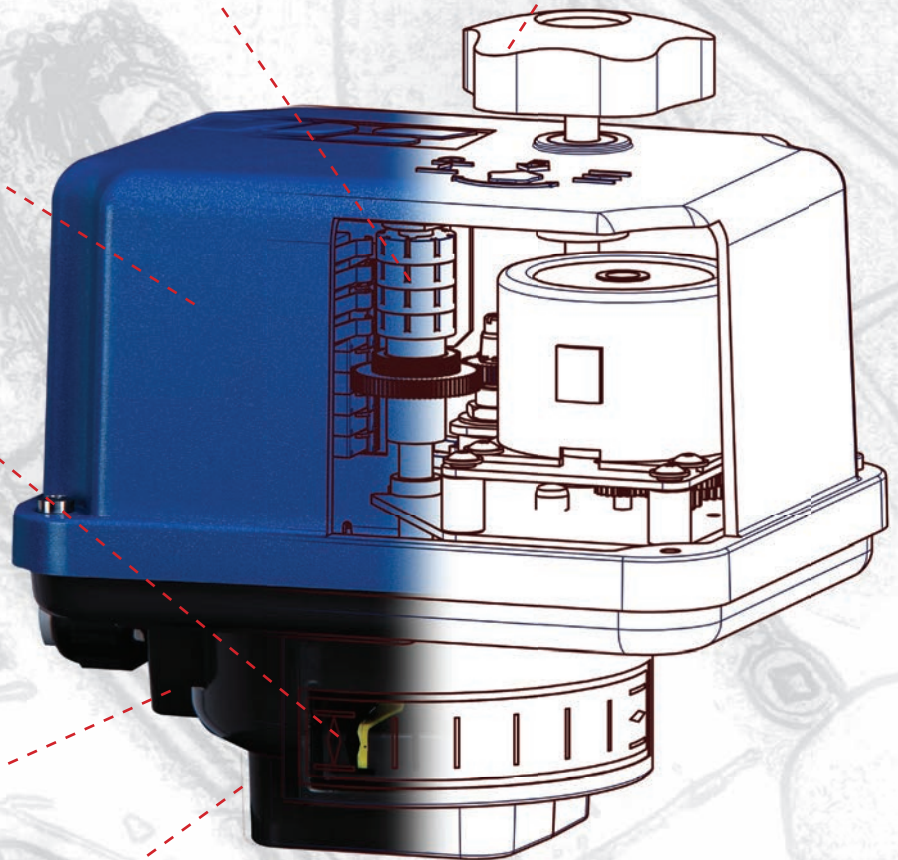

Technical data

PSR-E25

Max. torque	Nm	25			
Power supply	V	230 VAC 1~	115 VAC 1~	24 VAC 1~	24 VDC
Frequency	Hz	50	50	50	-
Operating time/90°	s	17	17	17	9
Weight	kg	2.8			
Duty cycle IEC 60034-1,8		S2 - 20 min, S3/S4 1200 c/h - 25% at 25°C			
Ambient temperature	°C	-25°C to +70°C			
Motor protection		Thermoswitch			Multifuse

PSR-E50

Max. torque	Nm	50			
Power supply	V	230 VAC 1~	115 VAC 1~	24 VAC 1~	24 VDC
Frequency	Hz	50	50	50	-
Operating time/90°	s	6, 33, 80	33	33	16
Weight	kg	2.8			
Duty cycle IEC 60034-1,8		S2 - 20 min, S3/S4 1200 c/h - 25% at 25°C			
Ambient temperature	°C	-25°C to +70°C			
Motor protection		Thermoswitch (except 80 s)			Multifuse

for details see data sheet

Dimensions

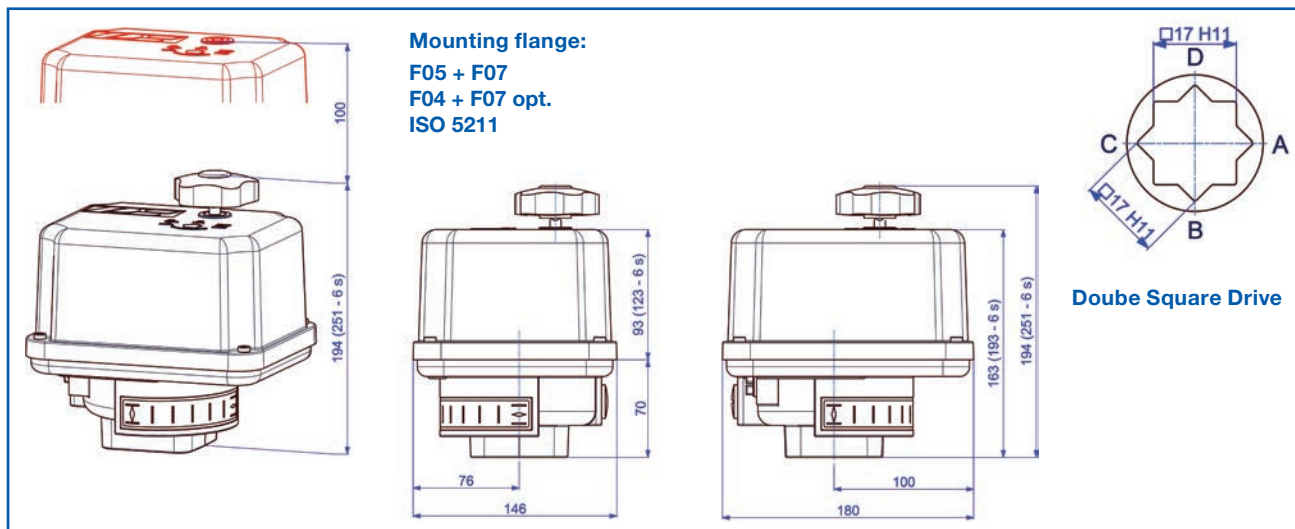

PS Automation GmbH
Gesellschaft für Antriebstechnik

Philipp-Krämer-Ring 13 • D-67098 Bad Dürkheim
Tel.: +49 (0) 63 22-60 03-0 • Fax: +49 (0) 63 22-60 03-20
info@ps-automation.com • www.ps-automation.com

Engineered and Made in Germany

