

# PSQ-E

PS Automation   
Gesellschaft für Antriebstechnik

*We care for actuation.*

## The efficient quarter-turn actuator

100 Nm - 150 Nm based on the proven PSQ102

**Pre-adjusted switching cams**  
2 x position and 2 x signal switches



**Spring-loaded terminals**

**Metal main frame**

**Synchronous motor**  
Motor blockable, integrated thermo switch.

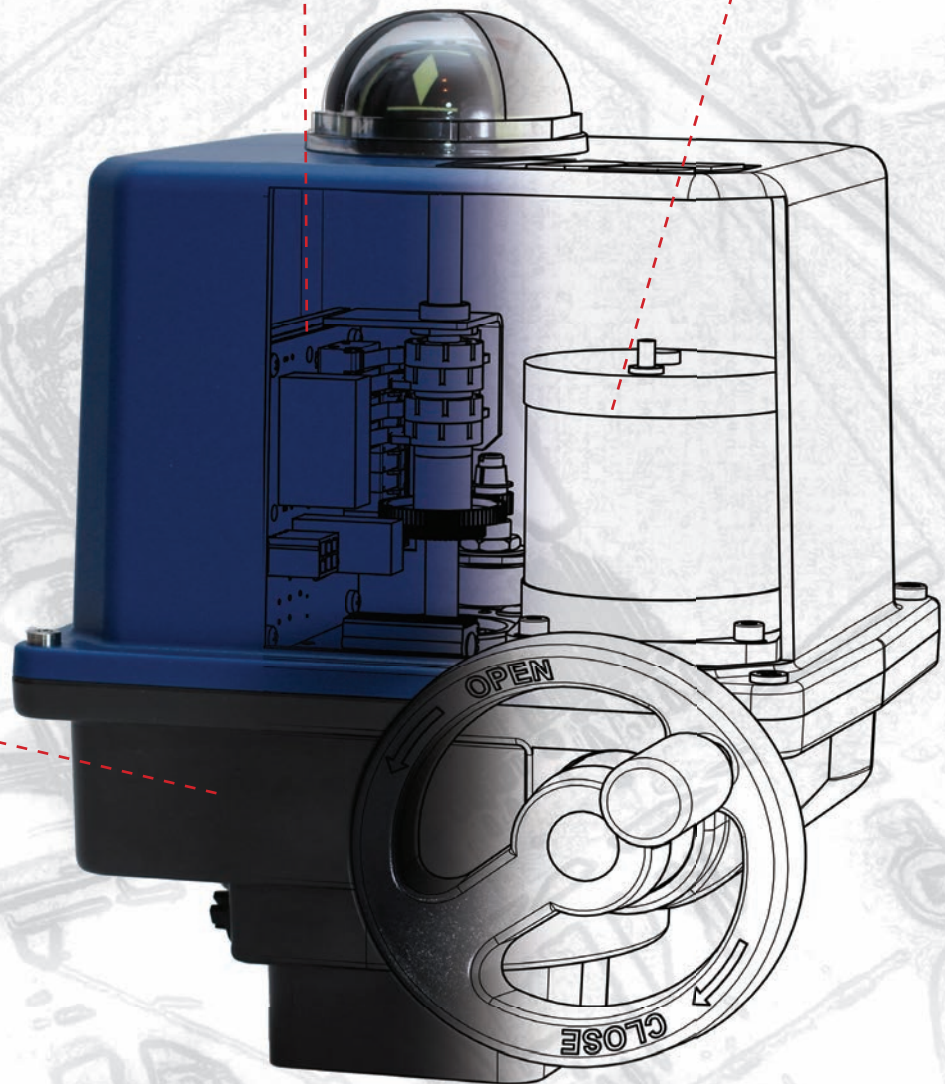

**Robust „Wolfrom“-planetary gear**  
Reduced power consumption due to highly efficient gear.

**IP67 Polycarbonate cover**  
with easily visible position indicator.



**Drive bush integrated**  
Double square drive, size 22 mm in the output wheel (Reduction pieces available for Square / Double D).



**Comfortable manual override**  
without locking mechanism. The handwheel does not rotate during motor operation.

## Technical Data

### PSQ-E100

Maximum torque	Nm	100				
Power supply	V	230 VAC 1~	115 VAC 1~	24 VAC 1~	400 VAC 3~	24 VDC
Operating time/90° [50 Hz / 60 Hz]	s	23 / 19				24
Nominal current	A	0.12	0.23	1.1	0.047 <sup>3)</sup>	0.8
Maximum current	A	0.14	0.28	1.3	0.07 <sup>3)</sup>	2.8
Power consumption <sup>2)</sup>	W	26	26	26	28	19
Duty cycle IEC 60034-1,8		S2 - 30 min, S3/S4 1200 c/h - 50% ED at 25°C				
Ambient temperature	°C	-25°C to +70°C				
Overvoltage category		II				
Motor protection		Thermo switch <sup>1)</sup>				Multifuse

### PSQ-E150

Maximum torque	Nm	150				
Power supply	V	230 VAC 1~	115 VAC 1~	24 VAC 1~	400 VAC 3~	24 VDC
Operating time/90° [50 Hz / 60 Hz]	s	23 / 19				24
Nominal current	A	0.17	0.3	1.44	0.075 <sup>3)</sup>	1.3
Maximum current	A	0.20	0.36	1.73	0.13 <sup>3)</sup>	2.8
Power consumption <sup>2)</sup>	W	39	34	34	45	31
Duty cycle IEC 60034-1,8		S2 - 30 min, S3/S4 1200 c/h - 50% ED at 25°C				
Ambient temperature	°C	-25°C to +70°C				
Overvoltage category		II				
Motor protection		Thermo switch <sup>1)</sup>				Multifuse

<sup>1)</sup> Thermo switch must be wired externally at 400VAC 3~

<sup>2)</sup> at maximum torque and 50 Hz

<sup>3)</sup> per phase

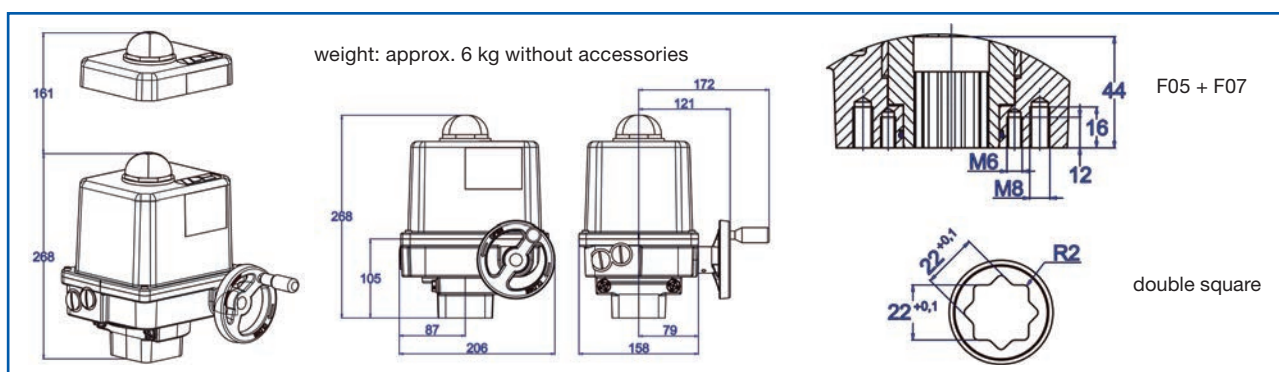

**PS Automation GmbH**  
Gesellschaft für Antriebstechnik

Philipp-Krämer-Ring 13 • D-67098 Bad Dürkheim  
Tel.: +49 (0) 63 22-60 03-0 • Fax: +49 (0) 63 22-60 03-20  
info@ps-automation.com • www.ps-automation.com

**Engineered and Made in Germany**

