

TCM 028K Series Coriolis Mass Flow Meter

Advantages:

- > Robust for long life
- > Customized installation length
- > Excellent repeatability
- > Optional net oil functionality

Benefits:

- > Increased productivity
- > Considerable cost savings for installation
- > Increased product quality
- > Increased well efficiency

Pressure Rating: 100 bar, 1450 psi

Specifications:

Mass Flow Rate (max.): 28000 kg/h, 1056 lb/min
 Volumetric Flow Rate (max.): 28000 l/h, 126.6 gpm, 4226 bbl/d
 Nominal Meter Size: DN25, 1"

Accuracy [liquids]:¹

Basic Accuracy [Mass Flow]: ± 0.1 % of flow rate
 Mass Flow Repeatability: ± 0.05 % of flow rate
 Basic Accuracy [Volume Flow]: ± 0.15 % of flow rate
 Volume Flow Repeatability: ± 0.05 % of flow rate
 Zero Stability: ± 0.01 % of full scale

Accuracy [gases]:

Basic Accuracy [Mass Flow]: ± 0.5 % of flow rate
 Mass Flow Repeatability: ± 0.25 % of flow rate

Density:

Density Range: up to 2500 kg/m³, 2.5 g/cm³
 Density Accuracy: Liquids ± 1.0 kg/m³, ± 0.001 g/cm³
 Density Repeatability: ± 0.5 kg/m³, ± 0.0005 g/cm³

Temperature:

Process Temperature Range: standard:
 -40 °C ... +100 °C, -40 °F ... +212 °F
 optional:
 -60 °C ... +200 °C, -76 °F ... +392 °F
 Temperature Accuracy: ± 1 °C ± 0.5 % of reading
 ± 1.8 °F ± 0.5 % of reading
 Temperature Repeatability: ± 0.2 °C, ± 0.36 °F

Materials of Construction [wetted parts]:

Tubes: 1.4404 / AISI 316L
 Case: 1.4301 / AISI 304 (1.4404 / AISI 316L)
 Flow Splitter: CF3M / AISI 316L
 Brazing Alloy: BNi-2

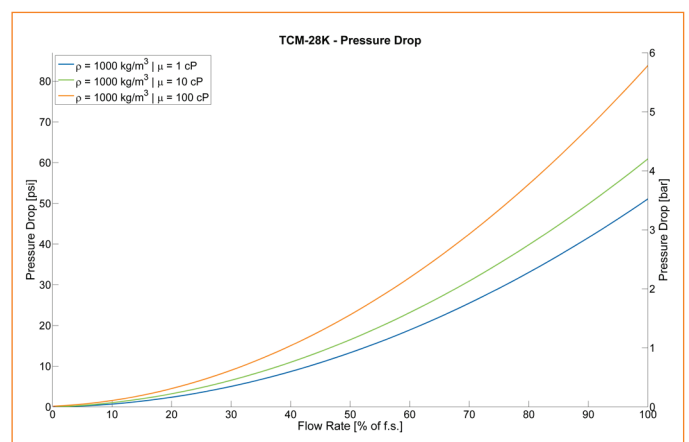

Meter Dimensions:¹

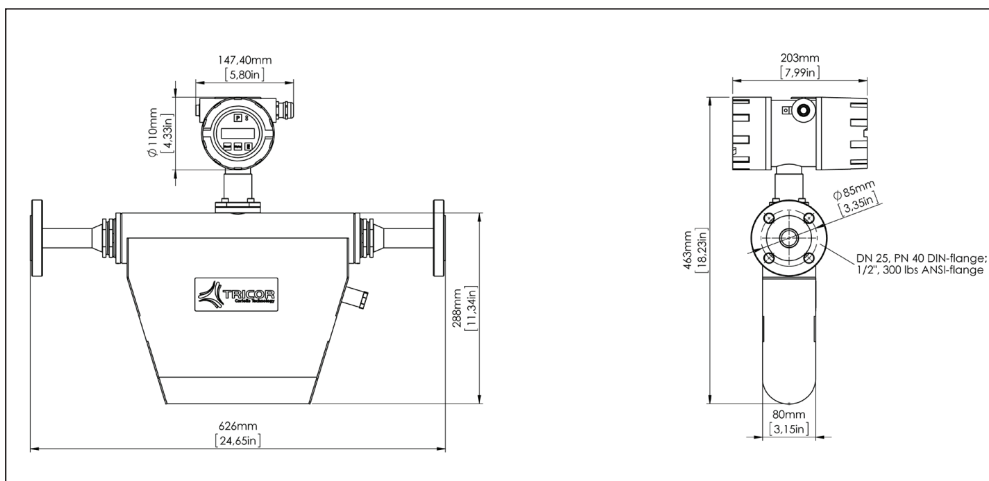

Compact Version

weight: 13.1 kg/30.2 lb
with meter mount ex-electronics
meter connection:
DN25 PN40/1" ANSI CL 300

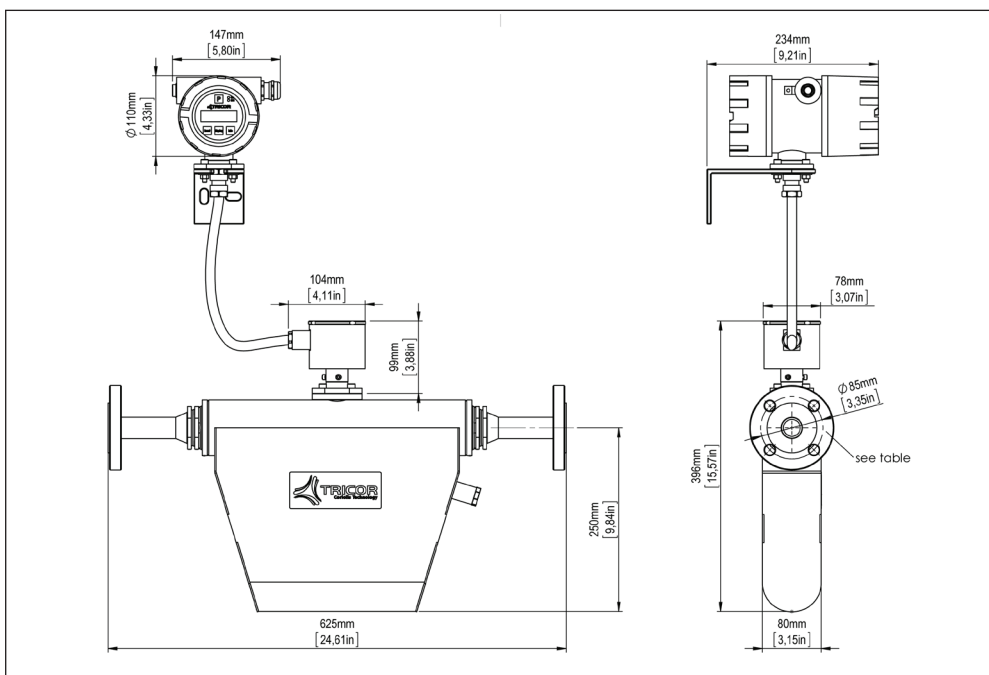

Remote Version

weight: 14.4 kg/33 lb
with junction box & remote field mount
meter connection:
standard meter connection according table

Electronics:

The TCE-8000 transmitter offered with the TRICOR Coriolis Mass Flow Meter is also available with other mounting options.

Ex Certifications:

ATEX	Zone 1: Group IIB, T4 Zone 2: II 3G Ex nA IIC, T4 Gc
IECEX	Zone 1: Group IIB, T4
cCSAus Ex	Class I, Division 1: Group C, D, T4

Panel Mount²



Remote Field Mount³



Power Supply: 24 V DC $\pm 20\%$ or 90 ... 264 V AC
Outputs: Analog, Frequency, Pulse, Status
Interface: RS485 RTU (Modbus), HART®
More options on request

¹ Drawing of the Meter Dimensions reflects one standard connection, other connections on request.
(Installation length can vary depending on selected connection)

² weight: 0.4 kg/0.88 lb

³ weight: 3.8 kg/8.3 lb with 3 m cable