



## BOURDON TUBE PRESSURE SWITCHES

## WEATHERPROOF: SERIES BW

## EXPLOSIONPROOF: SERIES BAX

<p>A pressure attachment B cable entry</p>	<p>A pressure attachment B cable entry</p>
WEIGHT 2 kg	WEIGHT 3,7 kg
dimensions in mm	dimensions in mm

**NOTE:** dimensions and weights are not binding unless released on certified drawings.

**CAUTION**

- Before installing, using or carrying out maintenance on the instrument it is necessary to **read** and **understand** the indications given in the attached Instruction Manual.
- The instrument must only be installed and maintained by **qualified personnel**.
- **INSTALLATION IS TO BE CARRIED OUT ONLY AFTER CHECKING THAT INSTRUMENT CHARACTERISTICS ARE CONSISTENT WITH PROCESS AND PLANT REQUIREMENTS.**
- The functional **features** of the instrument and its degree of protection are shown on the identification plate fixed to the case.

**CONTENTS:**

- 1 - GENERAL NOTES
- 2 - OPERATING PRINCIPLE
- 3 - IDENTIFICATION PLATE AND MARKINGS
- 4 - SET POINT REGULATION
- 5 - SET POINT CALIBRATION
- 6 - MOUNTING AND CONNECTIONS
- 7 - INSTRUMENT PLUMBING
- 8 - PUTTING INTO OPERATION
- 9 - FUNCTIONAL VERIFICATION
- 10 - TROUBLESHOOTING
- 11 - STOPPING AND DISMOUNTING
- 12 - DEMOLITION

SAFETY INSTRUCTIONS FOR USE IN HAZARDOUS ATMOSPHERES.

RECOMMENDATIONS FOR PRESSURE SWITCH SAFE USE.

All data, statements and recommendations supplied with this manual are based on information believed by us to be reliable. As the conditions of effective use are beyond our control, our products are sold under the condition that the user himself evaluates such conditions before following our recommendations for the purpose or use foreseen by him.

The present document is the property of **ETTORE CELLA SPA** and may not be reproduced in any form, nor used for any purpose other than that for which it is supplied.

### 1 - GENERAL NOTES

#### 1.1 FOREWORD

The wrong choice of a series or a model, as well as the incorrect installation, lead to malfunction and reduce instrument life.

Failure to abide by the indications given in this manual can cause damage to the instrument, the environment and persons.

#### 1.2 ALLOWED OVERRANGE

Pressure exceeding the working range can be **occasionally** tolerated provided they remain within the limits stated in the instrument features (vacuum or proof pressure). **Continuous** pressures exceeding the working range can be applied to the instrument provided they are clearly stated in the instrument features. The current and voltage values stated in the technical specifications and ratings must **not** be exceeded. Transitory overranges can have a destructive effect on the switch.

#### 1.3 MECHANICAL VIBRATIONS

Can generally lead to the wearing of some parts of the instrument or cause false actuation. It is therefore recommended that the instrument be installed in a place where there are no vibrations. In cases where this is impossible it is a good idea to take measures to lessen the effects (elastic supports, installation with the peg of the microswitch positioned at right angles to the vibration plane, etc.).

#### 1.4 TEMPERATURE

Due to the temperature of both the environment and the process fluid, the temperature of the instrument could exceed the allowed limits (normally from -20° to +85°C). Therefore, in case it does, suitable measures (protection against heat radiation, fluid separators, cooling coils, heated lockers) must be taken.

### 2 - OPERATING PRINCIPLE

The pressure, acting on the sensitive element (Bourdon tube), determines its elastic deformation which is used to activate one or two electric microswitches regulated at set point values. The microswitches are of the rapid release type with automatic rearm. When the pressure moves away from the set values, returning towards the normal values, the switch is rearmed. The differential gap (difference between the set point value and the reset value) can be set or adjustable (letter R in the contact codes).

### 3 - IDENTIFICATION PLATE AND MARKINGS

The instrument is fitted with a metal plate bearing all its functional characteristics and – in case of explosionproof execution (Series BAX) – also the markings prescribed by standard EN-60079-0 and EN-61241-0. Fig. 2 shows the plate mounted on explosionproof instruments.



Fig. 1 - Explosionproof instruments plate

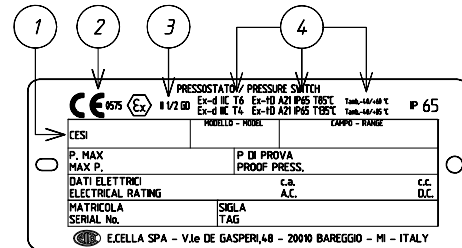

- 1 Notified body that issued the type certificate and number of said certificate.
- 2 CE marking and identification number of the notified body responsible for production surveillance.
- 3 Apparatus classification according to ATEX 94/9 CE directive.
- 4 Type of protection and ambient temperature limits of operation.

### 4 - SET POINT REGULATION

Each microswitch is independent and can be regulated by means of a screw (for adjustment) in such a way that it is released when the pressure reaches (increasing or decreasing) the desired value (set point).

The instrument is usually supplied with the switches set at the setting range value nearest to zero (**factory calibration**).

The instrument is supplied with an adhesive rating plate showing the set point calibration value. With **factory calibration** the values are not indicated on the ratings as these are temporary and will be modified with the definitive values.

Prior to installation the instrument must be **calibrated** and the definitive calibration values written on the adhesive rating plate using a suitable indelible ink pen.

If the instrument has been ordered with a **specific calibration**, it is a good rule to check the calibration values marked on the relevant adhesive label, prior to installation.



The position of the adjustment screws is given in figure The effect that the direction of rotation of the adjustment screws has is described on the adhesive plate.

Fig. 2 - Electrical connections and adjustment screws

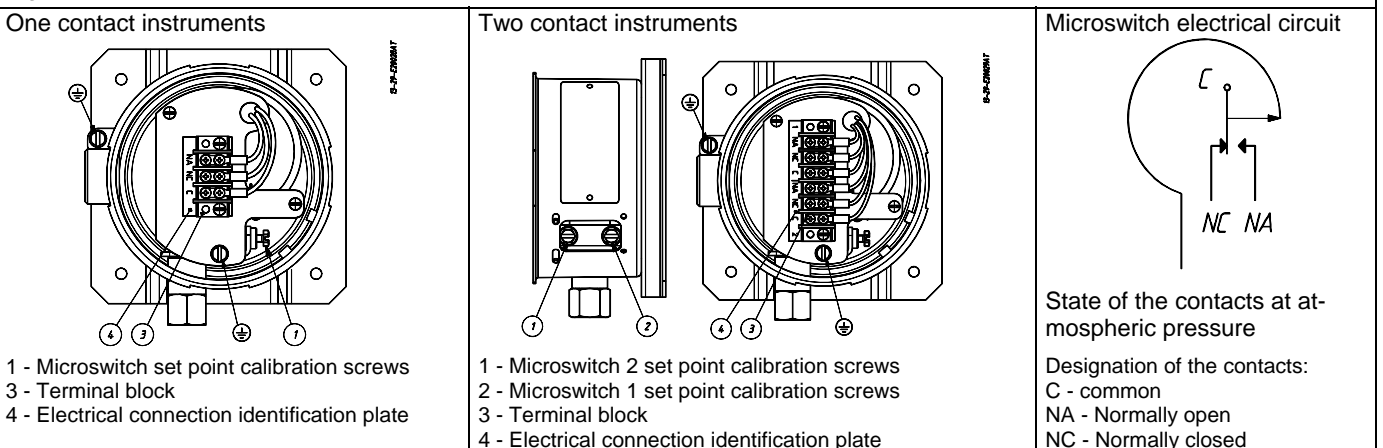

### 5 - SET POINT CALIBRATION

In order to proceed with the calibration and the periodical functional verification of the instrument a suitable **calibration circuit** (fig. 5) and an adequate pressure source is required.

#### 5.1 PRELIMINARY OPERATIONS

##### Weatherproof pressure switches (BWX)

Remove the blocking device fixed to the side of the instrument case and the adjustment screw access plate (Fig. 3). Remove the cover by rotating it in an anticlockwise direction.

Fig. 3 - Weatherproof pressure switch blocking device -

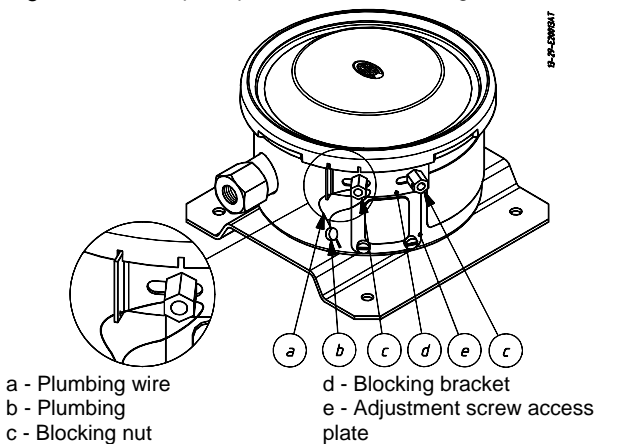

##### Explosionproof pressure switches (BAX) (Fig. 4)

**CAUTION:** do not open the cover of explosionproof pressure switches (Series BAX) when energized, in explosive atmospheres.

Loosen the locking headless screw situated on the cover using a 1,5 hexagonal key then unscrew the cover. Remove the internal blocking device inserted on the closure plugs and slide out the plugs.

Fig. 4 - Explosionproof pressure switch blocking device

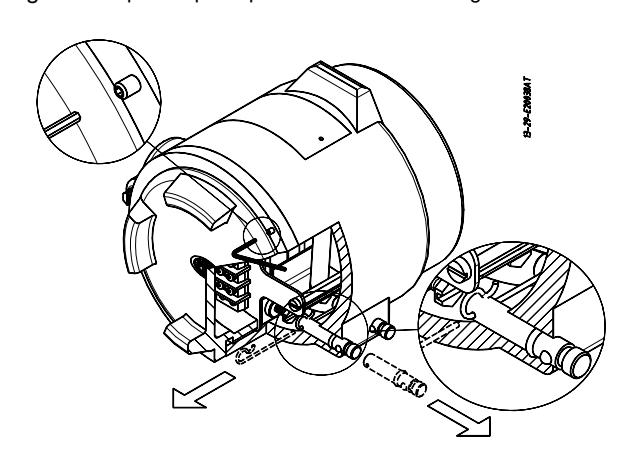

#### 5.2 CALIBRATION CIRCUIT AND OPERATIONS

Prepare the control circuit as indicated in Fig.5. The warning lamps should be connected to contact 1 or 2 in the NO or NC position according to the required contact action.

##### Connection of C and NO terminals

- If the circuit is open at the working pressure, the switch **closes** the circuit as the pressure **increases** when the desired value is reached.
- If the circuit is closed at the working pressure, the switch **opens** the circuit as the pressure **decreases** when the desired value is reached.

##### Connection of C and NC terminals

- If the circuit is closed at the working pressure, the switch **opens** the circuit as the pressure **increases** when the desired value is reached.
- If the circuit is open at the working pressure, the switch **closes** the circuit as the pressure **decreases** when the desired value is reached.

The test instrument should have a measurement range approximately equal to or slightly wider than the pressure switch range and should have an accuracy consistent with the precision required to calibrate the set point. The pressure switch must be mounted in the normal installation position, i.e. with the pressure connection pointing downwards.

Fig. 5 - Calibration circuit

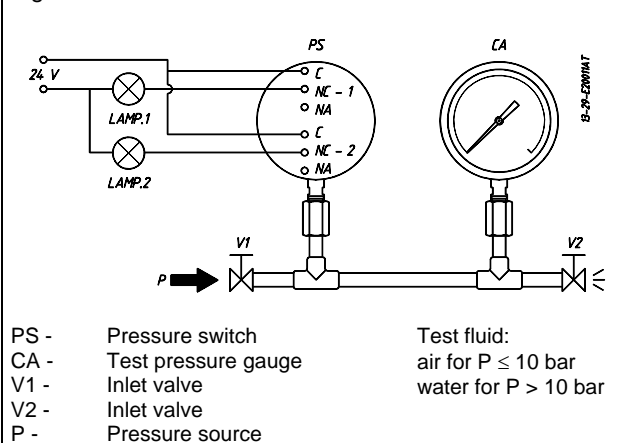

PS - Pressure switch  
CA - Test pressure gauge  
V1 - Inlet valve  
V2 - Inlet valve  
P - Pressure source

Test fluid:  
air for  $P \leq 10$  bar  
water for  $P > 10$  bar

Avoid forcing the elastic support of the microswitch by hand or with tools. This could affect the instrument functioning.

**CAUTION:** if the switch is of the kind with adjustable dead band (letter R in the contact codes) before proceeding with the following operations it is necessary to proceed with the adjustment of the dead band (see attachment NI-705 for model BWXUR and NI-704 for model BAXUR)

Increase the pressure in the circuit up to the desired set point value for the first microswitch.

Use a wide bladed screwdriver, as indicated on the adhesive plate, until the relative lamp turns on (or turns off).  
- If the instrument is equipped with only one contact the calibration is complete.

- If it is equipped with two contacts continue in the following manner.

Vary the pressure until the desired set point value for the second microswitch is reached.

Act on the adjustment screw of the second contact.

Repeat former operations on the first contact, then operations on the second contact, until the required set point precision is obtained. This is necessary due to the reciprocal influence which the microswitches have on the sensitive element of the instrument.

Check the calibration values (varying the pressure in the circuit accordingly) and record them on the adhesive plate using a pen with indelible ink.

#### 5.3 FINAL OPERATIONS

Disconnect the instrument from the calibration circuit

##### Weatherproof pressure switches (Series BWX)

Take the cover, ensure that the sealing gasket is correctly fitted into its seat, and insert the cover onto the case, with the blocking gap positioned in correspondence to the blocking bracket. Turn the cover clockwise closing it tightly. Mount the adjustment screw access plate, then the blocking device as in Fig. 3.

##### Explosionproof pressure switches (Series BAX).





Insert the closure plugs of the adjustment screw access holes, **block** them using the internal device and if necessary seal them with plumbing. Screw on the cover and **block** it using the headless screw with which it is equipped (Fig. 4).

Replace the supplied protection caps on the pressure attachment and cable conduit.



**IMPORTANT:** the protection caps should only be definitively removed **during** the connection steps (see §6).

## 6 - MOUNTING AND CONNECTIONS

### 6.1 MOUNTING

**Surface** mount the instrument by means of the holes provided, or **pipe** mount using the appropriate bracket (see Fig. 9). The chosen position must be such that vibrations, the possibility of shocks or temperature changes are within tolerable limits. The above also applies to direct mounting. With gas or vapour process fluid, the instrument **must** be positioned higher than the pipe inlet (see Fig. 8). With a liquid process fluid, the instrument can be positioned higher or lower, indifferently (see Fig. 7 e 8). ). In this case, during set point calibration the **negative** or **positive head** must be taken into account (distance h in fig.7 and 8).

### 6.2 PRESSURE CONNECTIONS

For a correct installation it is necessary to:

Mount a shut-off valve with drain (root valve) on the process tube to allow the instrument to be excluded and the connection tubing to be drained. It is recommended that said valve has a capstan-blocking device aimed at preventing it being activated casually and without authorisation.

Mount a service valve near the instrument to permit possible functional verification on site. It is recommended that the service valve is closed with a plug to prevent the outlet of the process fluid caused by the incorrect use of said valve.

Mount a three-piece joint onto the threaded attachment of the instrument to permit the easy mounting or removal of the instrument itself.

Carry out the connection using a flexible tube in such a way that variations in the temperature of the tube itself do not force the instrument attachment.

Ensure that all the pressure connections are airtight. It is important that there are no leakage in the circuit.

Close the root valve and the relative drain device.

Close the service valve using a safety plug.

### 6.3 ELECTRICAL CONNECTIONS

It is recommended to carry out the electrical connections according to the applicable standards. In case of explosionproof instruments (Series BAX) see also the Standard EN-60079-14 and EN-61241-14. If the electrical connection is carried out in a protected tube, it shall be made so that condensate is prevented from entering instrument enclosure.

The arrangement shown in Fig. 7 or 8 is therefore recommended.



**CAUTION:** fittings used for the electrical connection of the pressure switch Series BAX (explosionproof) shall be certified according to ATEX, and shall guarantee instrument degree of protection (IP65). To ensure anti-loosening of lock coupling or cable gland, we suggest to seal the thread of connection to the case with an anaerobic sealant. For example, you can use an anaerobic sealant type as Loctite ® 542.

Check that there is no power in the lines.

Remove the cover and carry out the cabling and connections to the terminal block (see Fig. 2).

Flexible cables with a maximum section of 1.2 mm<sup>2</sup> (16AWG) are recommended using the pre-insulated fork thimbles. **Do not touch the adjustment screws and do not bend** the elastic microswitch supports in order to prevent the instrument calibration being altered.

Ensure that no deposits or wire ends remain inside the case.

As soon as connection steps are completed, mount the cover on and make sure it is tight and blocked See Fig. 3 and 4.

### 6.4 SPECIAL NOTE FOR INSTALLATION OF CATEGORY 2 G D PRESSURE SWITCHES

Explosionproof pressure switches (Series BAX) can be installed on processes requiring apparatus of group II category 1 in an ambient requiring apparatus of group II category 2 (see Fig. 6).

Fig. 6 - Installation of Group II Cat. 2 GD instruments  
Gas (G)                      Dust (D)

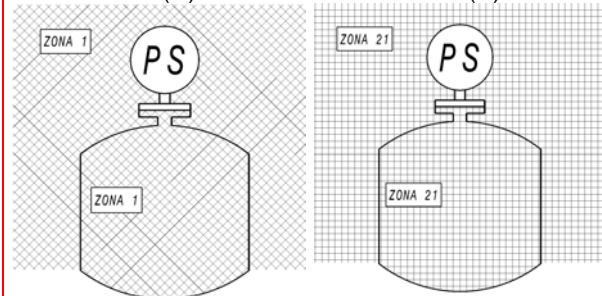

## 7 - INSTRUMENT PLUMBING

### Weatherproof pressure switches (Series BWX)

The plumbing, aimed as a guarantee against possible tampering of the calibration and electrical connections, can be carried out using a flexible steel wire (c) inserted into the holes in the screw (a) and the bracket (e) provided for this purpose (see Fig. 3).

### Explosionproof pressure switches (Series BAX)

Plumbing is not necessary as the cover is blocked with a headless screw, the closure plugs of the adjustment screw access holes are blocked by means of the internal blocking device and the instrument **does not** have to be opened when installed.







### 8 - PUTTING INTO OPERATION



As the signal transmitted by the instrument is used in a complex system, it is necessary that the means of putting it into operation are established by those in charge of the plant.

The instrument comes into operation as soon as the root valve is opened. Any possible drainage of the connection tubing can be carried out by removing the safety plug and **opening** the service valve **with the necessary caution**.



In case of explosionproof instruments (Series BAX), initial inspections are to be carried out according to customer procedures and at least in accordance with Standard EN-60079-17 and EN-61241-17.

### 9 - FUNCTIONAL VERIFICATION

This will be carried out according to the Client's control procedures. Series **BWX** instruments can be verified on the plant if installed as illustrated in Fig. 7 and 8.



The instruments Series **BAX** may be checked on site only if apparatus suitable for explosives atmosphere are used and provided that **the electric line is not energized**.

### 10 - TROUBLESHOOTING



**IMPORTANT NOTE: operations involving replacement of essential components must be carried out at our workshop, especially for instruments with explosionproof certificate; this is to guarantee the user the total and correct restoration of the product original characteristics.**

MALFUNCTION	PROBABLE CAUSE	REMEDY
Set point shift	<ul style="list-style-type: none"> <li>Permanent deformation of the sensitive element due to fatigue or non-tolerated over-ranges.</li> <li>Variation of the elastic features of the sensitive element due to its chemical corrosion.</li> </ul>	<ul style="list-style-type: none"> <li>Recalibrate or replace the sensitive element.</li> <li>Recalibrate or replace the sensitive element with another made of a suitable material. If necessary apply a fluid separator.</li> </ul>
Slow response	<ul style="list-style-type: none"> <li>Clogged or obstructed connection line.</li> <li>Root valve partially closed.</li> <li>Too viscous fluid.</li> </ul>	<ul style="list-style-type: none"> <li>Check and clean line.</li> <li>Open valve.</li> <li>Provide instrument with suitable fluid separator.</li> </ul>
No actuation or undue actuation	<ul style="list-style-type: none"> <li>Root valve closed.</li> <li>Microswitch contacts damaged.</li> <li>Loosened electrical joints.</li> <li>Interrupted or short-circuited electrical line.</li> </ul>	<ul style="list-style-type: none"> <li>Open the valve</li> <li>Replace the Microswitch.</li> <li>Check all electrical joints.</li> <li>Check the conditions of the electrical line.</li> </ul>
Undue actuation	<ul style="list-style-type: none"> <li>Accidental shocks or excessive mechanical vibrations.</li> </ul>	<ul style="list-style-type: none"> <li>Modify the mounting.</li> </ul>

### 11 - STOPPING AND DISMOUNTING



Before proceeding with these operations **ensure** that the plant or machines have been put into the **conditions** foreseen to allow these operations.

#### With reference to figures 7 and 8

Remove the power supply (signal) from the electrical line.

Close the root valve (6) and open the drain.

Remove the plug (2), open the valve (3) and wait until the process fluid has drained from the tubing through the drain.



Do not dispose of the process fluid into the environment, if this can cause pollution or damage to people.

Unscrew the three-piece joint (8).



**CAUTION:** do not open the cover of explosionproof pressure switches (Series BAX) when energized, in explosive atmospheres.

Unscrew the three-piece joint (10) (electrical cable tubing).

If this is not the case it is necessary to stop operation, dismount by means of the three-piece joints and carry out the verification in a test room.

**CAUTION:** do not open the cover of explosionproof pressure switches (Series BAX) when energized, in explosive atmospheres.

Verification consists in **checking the calibration value** and possibly **regulating the adjustment screw** (see §4).

In case of explosionproof instruments (Series BAX), inspections of the electrical installation are to be carried out also according to customer procedures and at least in accordance with Standard EN-60079-17 and EN-61241-17.

The explosionproof instruments (series BAX) installed in explosive atmospheres for the combustible dust presence, must be periodically cleaned up externally in order to avoid dust accumulating.



Remove the instrument cover and disconnect the electrical cables from the terminal block and earth screws.

Remove the screws fixing the case to the panel (or pipe) and remove the instrument, taking care to slide the electrical conductors out from the case.

Replace the instrument cover. Insulate and protect the conductors remaining on the plant. Temporarily plug the tubing (4).

In case of explosionproof instruments (Series BAX) it is recommended to follow - at least - the standard EN-60079-17 and EN-61241-17 for the withdrawal from service of electrical apparatus.

### 12 - DEMOLITION

The instruments are mainly made of stainless steel and aluminium and therefore, once the electrical parts have been dismantled and the parts coming into contact with fluids which could be harmful to people or the environment have been properly dealt with, they can be scrapped.

### WEATHERPROOF

Fig. 7 - Example of connections -

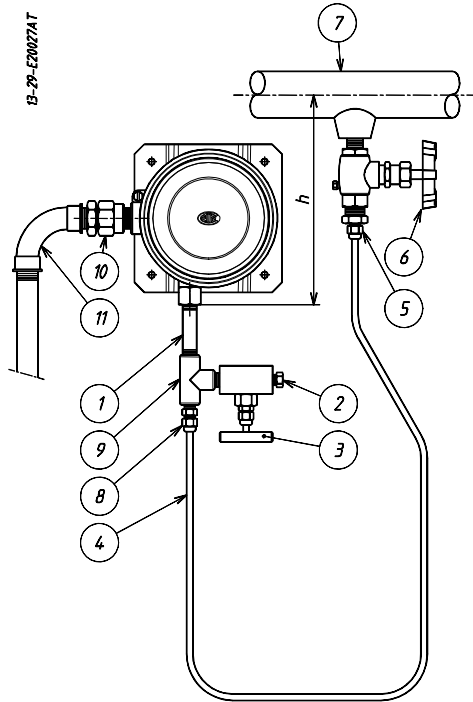

### EXPLOSIONPROOF

Fig. 8 - Example of connections -

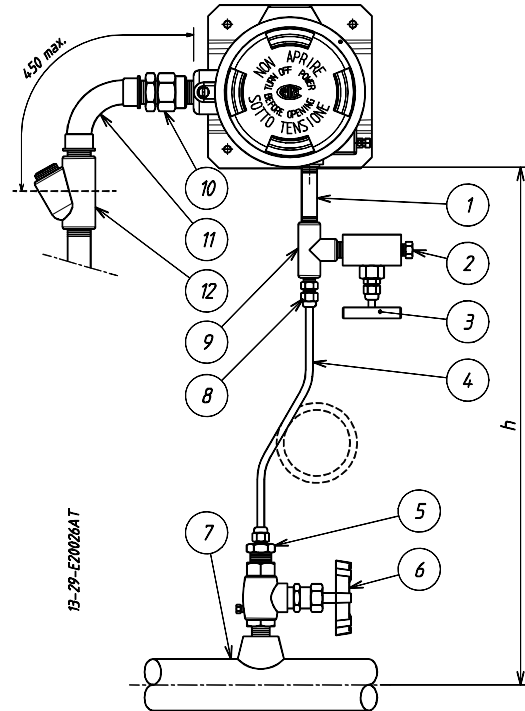
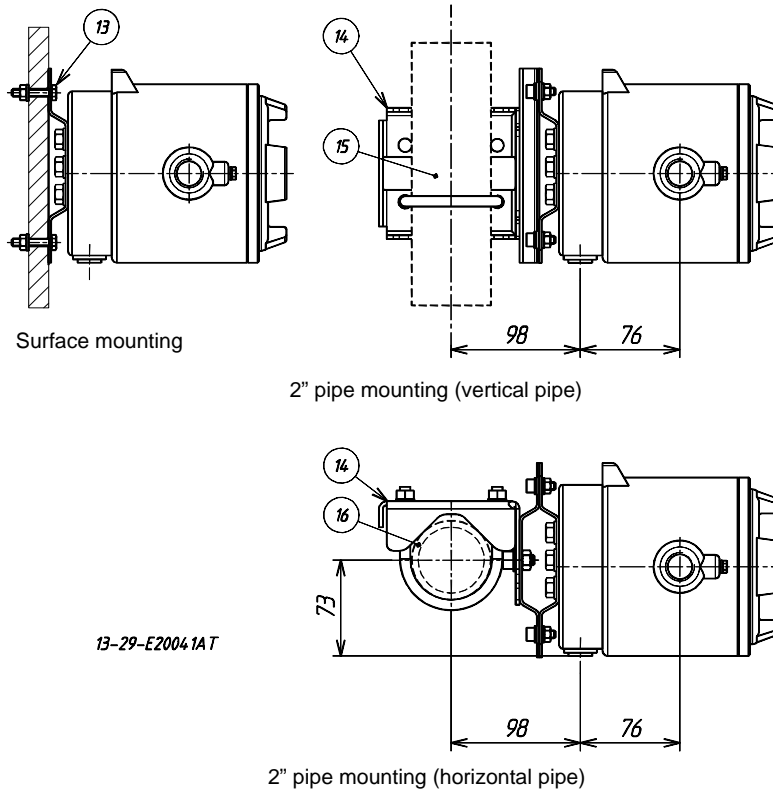

Fig. 9 - Example of mounting -



**NOTE** With gas or vapour process fluid, the instrument **must** be positioned higher than the pipe inlet (see Fig. 8). With a liquid process fluid, the instrument can be positioned higher or lower, indifferently (see Fig. 7 and 8). In this case, during set point calibration the **negative** or **positive** head must be taken into account. (Distance h in Fig.7 and 8).

#### LEGEND

- 1 - Fitting
- 2 - Drain plug
- 3 - Service valve
- 4 - Piping
- 5 - Three piece fitting
- 6 - Root valve with drain
- 7 - Process piping
- 8 - Three piece fitting
- 9 - "T" fitting
- 10 - Three piece fitting
- 11 - Curve
- 12 - Blocking joint
- 13 - M6 screws (No. 4)
- 14 - Bracket for 2" pipe
- 15 - Vertical pipe
- 16 - Horizontal pipe