



PRESSURE SWITCHES SERIES PXS, PXN, PXA

WEATHERPROOF (Series PXS) AND EXPLOSIONPROOF (Series PXA, PXN)

INSTRUMENT STANDARD	INSTRUMENT WITH JUNCTION BOX		
A = Pressure connection	B = Cable entry	A = Pressure connection	B = Cable entry
WEIGHT 0,3 kg	WEIGHT 1kg		Dimensions in mm

NOTE: dimensions and weights are not binding unless released on certified drawings.

CAUTION

- Before installing, using or carrying out maintenance on the instrument it is necessary to **read** and **understand** the indications given in the attached Instruction Manual.
- The instrument must only be installed and maintained by **qualified personnel**.

• INSTALLATION IS TO BE CARRIED OUT ONLY AFTER CHECKING THAT INSTRUMENT CHARACTERISTICS ARE CONSISTENT WITH PROCESS AND PLANT REQUIREMENTS.

- The functional **features** of the instrument and its degree of protection are shown on the identification plate fixed to the case.

CONTENTS:

- 1 - GENERAL
- 2 - OPERATING PRINCIPLE
- 3 - NAMEPLATE AND MARKINGS
- 4 - SPECIAL CONDITIONS FOR SAFE USE (X)
- 5 - SET POINT ADJUSTMENT
- 6 - SET POINT CALIBRATION
- 7 - INSTRUMENT PLUMBING
- 8 - MOUNTING AND CONNECTION S
- 9 - PUTTING INTO OPERATION
- 10 - FUNCTIONAL VERIFICATION
- 11 - TROUBLE SHOOTING
- 12 - STOPPING AND DISMOUNTING
- 13 - DEMOLITION

SAFETY INSTRUCTIONS FOR USE IN EXPLOSIVE ATMOSPHERES

RECOMMENDATIONS FOR THE SAFE USE OF THE INSTRUMENT

DOCUMENT CORRELATED

to document authenticated with certificates
 N° CESI 05 ATEX 002X
 N° CESI 05 ATEX 003

All data, statements and recommendations supplied with this manual are based on information believed by us to be reliable. As the conditions of effective use are beyond our control, our products are sold under the condition that the user himself evaluates such conditions before following our recommendations for the purpose or use foreseen by him.

The present document is the property of **ETTORE CELLA SPA** and may not be reproduced in any form, nor used for any purpose other than for which it is supplied.





1 - GENERAL

1.1 FOREWORD

The wrong choice of a series or a model, as well as the incorrect installation, lead to malfunction and reduce instrument life. Failure to follow the indications given in this manual can cause damage to the instrument, the environment and persons.

1.2 ALLOWED OVERRANGES

Pressures exceeding the working range can be **occasionally** tolerated provided they remain within the limits stated for the instrument (proof pressure). **Continuous** pressures exceeding the working range can be applied to the instrument, provided they are clearly stated in the instrument features.

The current and voltage values stated in the technical specifications and data plate must **not** be exceeded: transitory overranges can have a destructive effect on the switch.

1.3 TEMPERATURES

Due to the temperature of both the environment and the process fluid, the temperature of the instrument could exceed the allowed limits (normally from -40°C to +85°C). Therefore, in case it does, suitable measures (protection against heat radiation, fluid separators, cooling coils, heated lockers), aimed at limiting the value, must be taken.

2 - OPERATING PRINCIPLE

A pressure-tight diaphragm (or an O-ring sealed piston) applies a force to a stiff disc. This force is directly proportional to the pressure value and is contrasted by an helicoidal spring charged by a suitable bush. When the force balance point is exceeded, the stiff disc shifts and, by means of a rigid rod, **actuates one or two simultaneous release electric microswitches**. The microswitches are of the snap acting type with automatic reset. When the pressure moves away from the set values, returning towards the normal values, the switch is reset.

3 - NAMEPLATE AND MARKINGS

The instrument is fitted with a metal plate bearing all its functional characteristics and – in case of explosionproof execution (Series PXA and PXN) – also the markings prescribed by standard EN 50014 and EN 50281-1-1. Fig. 1 shows the nameplate mounted on explosionproof instruments.

Fig. 1. Nameplate, explosionproof instruments

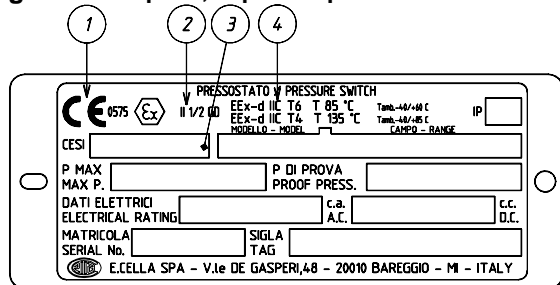

- 1 CE marking and identification number of the notified body responsible for production surveillance.
- 2 Apparatus classification according to ATEX 94/9 CE directive.
- 3 Notified body that issued the type certificate and number of said certificate.
- 4 Mode of protection and operating ambient temperature limits.

4 - SPECIAL CONDITIONS FOR SAFE USE (X)

Explosionproof instruments (Series PXA and PXN) installed without a junction box require an electric connection suitable for the mode of protection chosen at the free end of the cable (see Point 8). Should the instrument be installed on a dangerous process fluid (Zone 0), check wetted materials compatibility.

5 - SET POINT ADJUSTMENT

The charge of the helicoidal spring can be regulated by means of the bush (for adjustment) in such a way that the switch is released when the pressure reaches (either increasing or decreasing) the desired value (set point). The instrument is usually supplied with the switches set at the setting range value nearest to zero (**factory calibration**). The instrument is supplied with an adhesive label showing the set point calibration value. With **factory calibration** the values are not indicated on the label as these are temporary and will be modified with the definitive values. Prior to installation the instrument **must be calibrated** and the definitive calibration values written on the label using a suitable indelible ink pen.

If the instrument has been ordered with a **specific calibration**, it is a good rule to check the calibration values marked on the relevant adhesive label, prior to installation.



The position of the adjusting bush is given in Fig. 2.

Fig. 2. Adjusting bush and plumbing

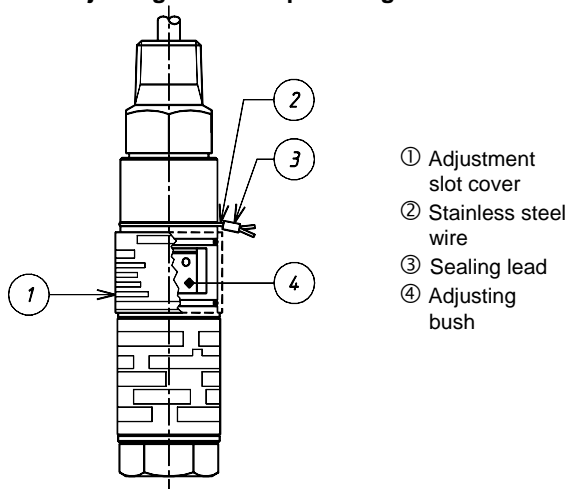

- ① Adjustment slot cover
- ② Stainless steel wire
- ③ Sealing lead
- ④ Adjusting bush

The effect of the sense of rotation of the adjusting bush is shown on the slot cover. Rotate the bush by inserting a 3mm dia. rod or drill into the holes on the bush itself.

6 - SET POINT CALIBRATION

In order to proceed with the calibration and the periodical functional verification of the instrument a suitable **calibration circuit** (Fig. 4) and an adequate pressure source are required. Wiring is to be carried out as shown in Fig. 3 and on the slot cover.

Fig. 3. Electric wiring

GDN - Ground internal : leadwire yellow/green	Micro 1
C - Common : leadwire brown	
NA - Normally open : leadwire blue	
NC - Normally closed : leadwire black	Micro 2
C - Common : leadwire grey	
NA - Normally open : leadwire red	
NC - Normally closed : leadwire white	

Microswitch internal wiring and contacts status at atmospheric pressure

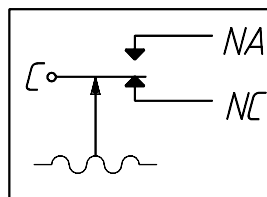

- C** - Common
- NA** - Normally open
- NC** - Normally closed

6.1 PRELIMINARY OPERATIONS

Slide up the adjustment cover (Fig. 2, 1).

6.2 CALIBRATION CIRCUIT AND OPERATIONS

Prepare the control circuit as indicated in Fig.4.

The warning lamps should be connected to the terminals NA or NC according to the required contact action.

If the instrument is equipped with two contacts, remember that they are released simultaneously but within the specification tolerance.

Connection between C and NA

- If the circuit is open at the working pressure, the instrument **closes** the circuit when the set point is reached with pressure **on rise (closure on rise)**.

- If the circuit is closed at the working pressure, the instrument **opens** the circuit when the set point is reached with pressure **on fall (opening on fall)**.

Connection between C and NC

- If the circuit is closed at the working pressure, the instrument **opens** the circuit when the set point is reached with pressure **on rise (opening on rise)**.

- If the circuit is open at the working pressure, the instrument **closes** the circuit when the set point is reached with pressure **on fall (closure on fall)**.

The test instrument should have a measurement range approximately equal to or slightly wider than the pressure switch range and should have an accuracy consistent with the precision required to calibrate the set point.

The pressure switch must be kept in the normal installation position, i.e. with the pressure connection downwards.

Modify the pressure in the circuit up to the desired microswitch set point value.

Turn the adjusting bush using the adjustment rod until the relative lamp turns on (or turns off); then turn it in the opposite direction until the lamp turns off (or on). Slowly turn the bush again until the lamp turns on (or off).

Fig. 4. Calibration circuit

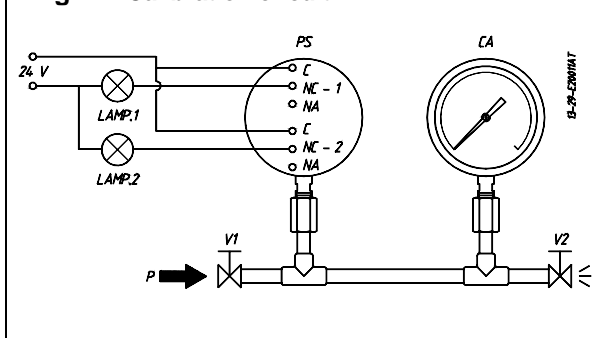

PS - Pressure switch	Test fluid :
CA - Test gauge	- air for P ≤ 10 bar
V1 - Inlet valve	- water for P > 10 bar
V2 - Discharge valve	
P - Pressure source	

Check the calibration value (varying the pressure in the circuit accordingly) and register it, using a pen with indelible ink, on the adhesive label.

6.3 FINAL OPERATIONS

Disconnect the instrument from the calibration circuit.

Close the adjustment slot by sliding down the slot cover (Fig. 2, 1), then seal with lead the instrument.

Mount on pressure connection the protecting cap supplied with the instrument. It should be definitively removed only during the connection steps.

7 - INSTRUMENT PLUMBING

The plumbing (see Fig. 2), aimed as a guarantee against possible tampering of the calibration, can be carried out using a flexible steel wire (2), 1 mm² in section, wound up around the case in the groove purposely provided.

8 - MOUNTING AND CONNECTION S

8.1 MOUNTING

Mount the instrument directly on the pressure tap (Fig. 11) or on a surface, through either a manifold (Fig.9) or a junction box (Fig. 10). If the optional bracket for surface or pipe mounting is used, refer to NI-292E. The chosen position must be such that possible shocks or temperature changes remain within tolerable limits. With gas or vapour process fluid, the instrument **must** be positioned higher than the pressure tap. With a liquid process fluid, the instrument can be positioned higher or lower, indifferently. In this case, during set point calibration the **negative** or **positive** head must be taken into account.

8.2 PRESSURE CONNECTION

For a correct surface mounting (Fig. 9 and 10) proceed as follows.

Mount a shut-off valve with drain (root valve) on the pressure tap to allow the instrument to be excluded and the connection tubing to be drained. It is recommended that said valve has a capstan-blocking device aimed at preventing it from being activated casually and without authorisation.

Mount a service valve near the instrument to permit possible functional verification on site. It is recommended that the service valve is closed with a plug to prevent the outlet of the process fluid caused by the incorrect use of said valve.

Mount a three piece joint onto the threaded attachment of the instrument to permit the easy mounting or removal of the instrument itself.

CAUTION: the pressure connection is to be tightened applying the wrench ONLY on the hex of the pressure attachment, NOT to the hex of the conduit connection, which may cause the instrument NOT to work (Fig.5).

Fig. 5. Pressure connection

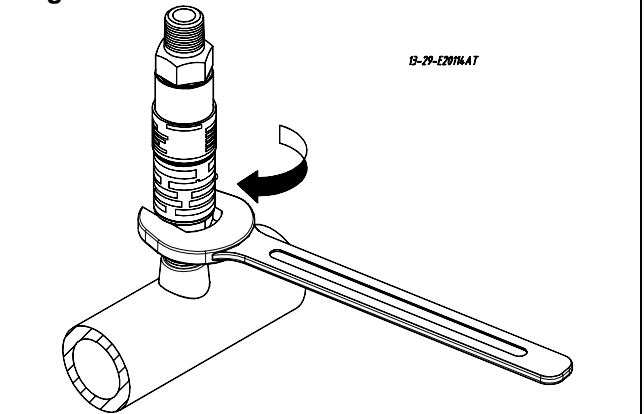

Make use of a flexible tubing between instrument and pressure tap so that, due to temperature changes, no mechanical stress be applied to instrument connection.

Make sure that all the pressure junctions are leakproof. It is important that there are no leakages in the circuit.

Close the root valve, the relative drain device and the service valve fitted with safety plug.

8.3 ELECTRICAL CONNECTIONS

It is recommended to carry out the electrical connections according to the applicable standards. In case of explosionproof instruments (Series PXA and PXN) see also the standards EN-60079-14 and EN 50281-1-2

The following mounting arrangements are possible.

8.3.1 MOUNTING WITH CABLE LOOSE

Run the cable so that it cannot be easily damaged (e.g. due to too narrow bends, heat sources) and strain it.

Mount, if provided, the external ground device on the electrical connection of the instrument. This device is to be threaded on, while holding the electrical connection steady with a 27 mm wrench on hex, until it reaches the bottom of the thread (Fig. 6).

The external ground screw is obligatory for explosionproof constructions.

Fig. 6. Mounting of ground device

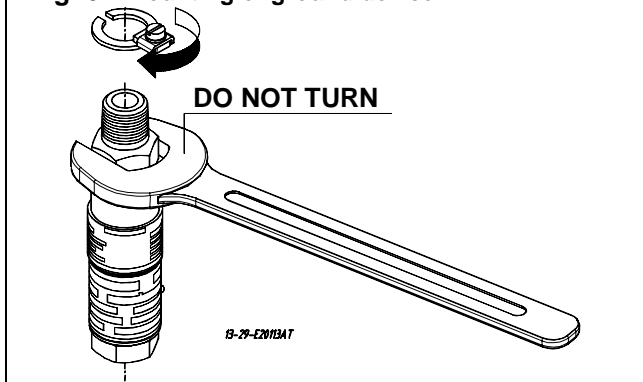

8.3.2 MOUNTING WITH CABLE PROTECTED BY FLEXIBLE TUBING

Mount, if provided, the external ground device on the electrical connection of the instrument. This device is to be threaded on, while holding the electrical connection steady with a 27 mm wrench on hex, until it reaches the bottom of the thread (Fig. 6)..

The external ground screw is obligatory for explosionproof constructions.

If the flexible tubing is fitted with a male thread, apply a sleeve to the electrical connection.

CAUTION: the sleeve is to be threaded on while holding the electrical connection steady with a 27 mm wrench on hex (Fig.7) .

Fig. 7. Mounting of adaptors

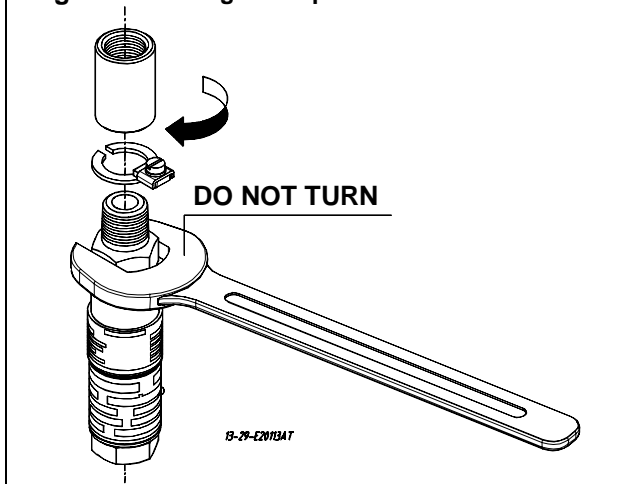

8.3.3 MOUNTING WITH CABLE PROTECTED BY METAL TUBING

CAUTION: mounting with cable protected by metal tubing is to be carried out avoiding any torque on the electrical connection while assembling the various fittings (Fig. 7).

In order to make easier the instrument removal for check and calibration it is advisable to apply on the instrument a junction box provided with terminals.

CAUTION: accessories used for installation have to be certified according to standards EN 50014, 50018, EN 50281-1-1 and guarantee the degree of protection of the instrument (IP65).

8.3.4 MOUNTING WITH INSTRUMENT FITTED WITH JUNCTION BOX

Models fitted with junction box feature three cable entries, three- or six-terminals block with terminals identification plate, internal and external grounding connections.

Terminals are identified as follows:

Identification No.	Function	Micro No.
1	Common	1
2	Normally Open	
3	Normally Closed	
4	Common	2
5	Normally Open	
6	Normally Closed	

Mounting with cable protected is to be carried out so as to prevent possible condensate from entering the junction box.

The junction box is to be surface mounted using the bracket supplied with it.

CAUTION: accessories used for installation have to be certified according to standards EN 50014, 50018, EN 50281-1-1 and guarantee the degree of protection of the instrument (IP65)

CAUTION: cable entries not used **must** be plugged and sealed with the plugs provided so as to prevent raining water or other from entering the junction box. In case of explosionproof instruments these plugs, if not correctly mounted and blocked to prevent their removal, do NOT guarantee the mode of protection EEx-d. Furthermore, in order to guarantee the degree of protection IP65 and the non-loosening of blocking joint or packing gland, it is prescribed to seal the threads of connection with the same anaerobic sealant used for the plugs. For instance, a sealant like Loctite ® 648 can be applied on the thread of plugs, blocking joint or packing gland before screwing them on the box.

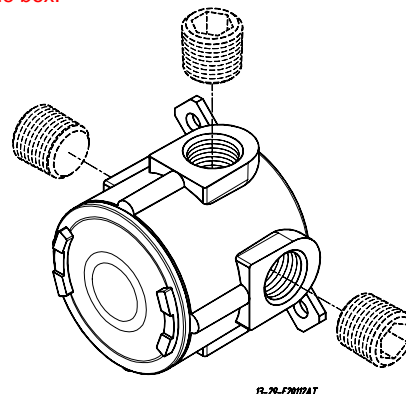

8.4 WIRING

The cable used for electric wiring has a 7 mm OD silicone sheath for one contact models, 8 mm OD for two contact models. Each wire has a section of 0,5 mm² (20 AWG) and is silicone insulated. Wires ends are factory tinned. The colour of insulator defines the contact function (see Fig. 3 and stampings on slot cover).

Before starting wiring, check that electric lines are not powered.

The instrument is to be grounded according to applicable electrical codes. Make use of the internal yellow-green wire and, if the cable is not protected by metal tubing, connect the external screw of the groundig device supplied with the instrument.

Should the instrument be fitted with junction box, make sure that no deposits or wire ends remain inside the box. The wiring completed, put the cover on and tighten it.

8.5 SPECIAL NOTE FOR THE INSTALLATION OF PRESSURE SWITCHES CATEGORY 1 / 2 G AND 1 / 2 D

Explosionproof pressure switches (Series PXA) may be installed on process requiring apparatus of Group II Category 1 in an area requiring apparatus of Group II Category 2 (see Fig. 8).

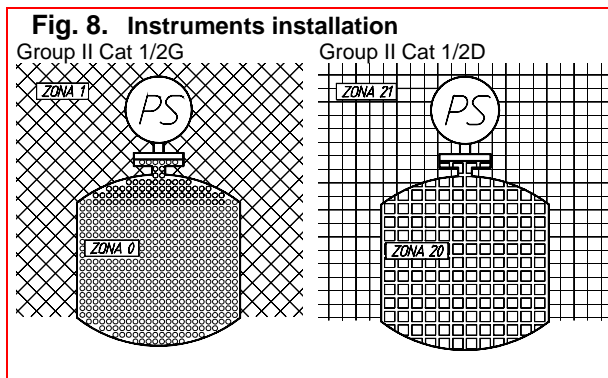

8.6 SPECIAL NOTE FOR THE INSTALLATION OF PRESSURE SWITCHES CATEGORY 3GD MODE OF PROTECTION EEx - nC

Explosionproof instruments Series PXN are to be installed using electric accessories prescribed for this execution. For instance, junction boxes are to be suitable for mode of protection n. Apply to standards EN-50021 for any construction detail and to EN-60079-14, EN-50281-1-2 for installation.

9 - PUTTING INTO OPERATION

As the signal transmitted by the instrument is used in a complex system, it is necessary that the means of putting it into operation are established by those in charge of the plant.

11 - TROUBLE SHOOTING

IMPORTANT NOTE: operations involving replacement of essential components must be carried out at our workshop, especially for instruments with explosionproof certificate; this is to guarantee the user the total and correct restoration of the product original characteristics.

MALFUNCTION	PROBABLE CAUSE	REMEDY
Set point shift	<ul style="list-style-type: none"> Permanent deformation of the sensitive element due to fatigue or excess over-ranges. Variation of the elastic features of the sensitive element due to its chemical corrosion. 	<ul style="list-style-type: none"> Recalibrate or replace the sensitive element.
Slow response	<ul style="list-style-type: none"> Clogged or obstructed connecting line. Root valve partially closed. Too viscous fluid. 	<ul style="list-style-type: none"> Recalibrate or replace the sensitive element with another made of a suitable material. If necessary apply fluid separator.
No actuation or undue actuation	<ul style="list-style-type: none"> Root valve closed. Microswitch contacts damaged. Loosened electrical joints. Interrupted or short-circuited line. 	<ul style="list-style-type: none"> Check and clean line. Open the valve. Provide instrument with suitable fluid separator.
Undue actuation	<ul style="list-style-type: none"> Accidental shocks. 	<ul style="list-style-type: none"> Open the valve. Replace instrument. Check all electrical joints. Check conditions of the electric line.
		<ul style="list-style-type: none"> Modify mounting.

12 - STOPPING AND DISMOUNTING

Before starting the following operations, ensure that plant and equipments have been put in conditions allowing to carry out them safely.

With reference to Fig 10.

Remove the power supply (signal) from the electric line. Close the root valve (10) and open drain. Remove plug (5), open valve (6) and wait for process fluid to drain out.

Do not dispose of the process fluid into the environment, if this can cause pollution or damage to people.

Unscrew the three-piece joints (11) and (3) (electric cable tubing). Remove cover from junction box and disconnect wires from terminals and grounding screws. Remove the screws fixing the box to the panel (or pipe) and remove the instrument taking care to slide electric conductors out from the case.

The instrument starts operating as soon as the root valve is opened. Any possible drainage of the connection tubing can be carried out by removing the safety plug and opening the service valve with the necessary caution.

In case of explosionproof instruments (Series PXA and PXN), initial inspections are to be carried out according to customer procedures and at least in accordance with Standards EN-60079-17 and EN-50281-1-2.

10 - FUNCTIONAL VERIFICATION

It will be carried out according to customer control procedures.

Explosionproof instruments (Series PXA, PXN) installed in hazardous areas due to the presence of inflammable dusts should be periodically cleaned externally to avoid dust accumulation.

Instruments Series PXS may be checked on site if installation has been made according to Fig. 9 to 12.

Instruments Series PXA, PXN may be checked on site but if testing equipments are suitable for the environment and electric supply is off.

Otherwise it is necessary to stop them working, remove them and carry out checks in a test room.

The verification consists in checking the calibration value and adjusting it if required (see §5).

In case of explosionproof instruments (Series PXA and PXN) inspections of the electrical installation are to be carried out also according to customer procedures and at least in accordance with Standards EN-60079-17, EN-50281-1-1.

Replace the cover on the box. Insulate and protect the conductors remaining on the plant. Temporarily plug the tubing (7). In case of explosionproof instruments (Series PXA, PXN) it is recommended to follow - at least - the Standards EN-60079-17 and EN-50281-1-2 for the withdrawal from service of electrical apparatus.

13 - DEMOLITION

The instruments are mainly made of stainless steel and aluminium and therefore, once the electrical parts have been dismantled and the parts coming into contact with fluids which could be harmful to people or to environment have been properly dealt with, they can be scrapped.

WEATHERPROOF OR EXPLOSIONPROOF

Fig. 9. Example of surface mounting

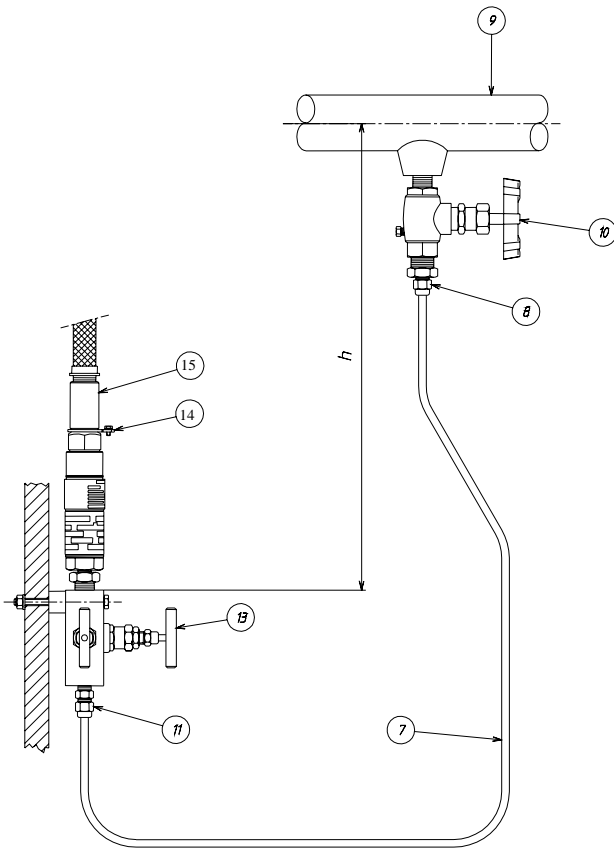

B-29-E20107AT

Fig. 10. Example of surface mounting

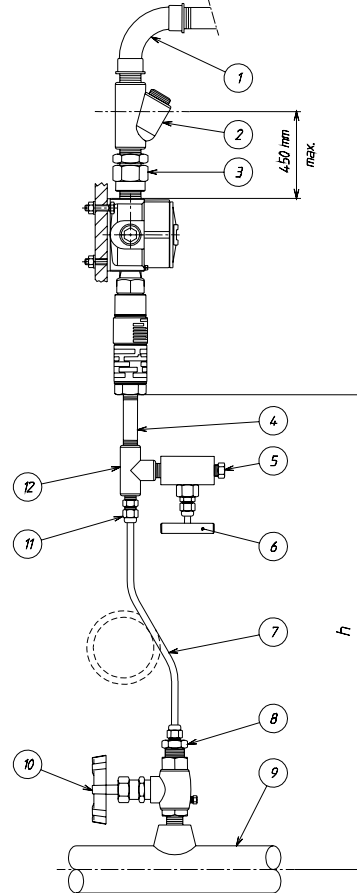
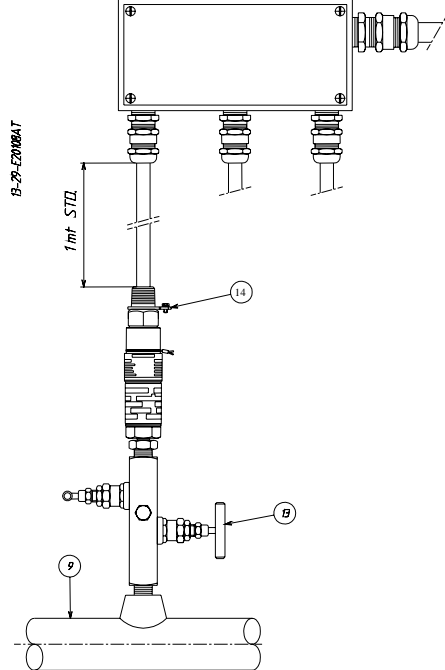
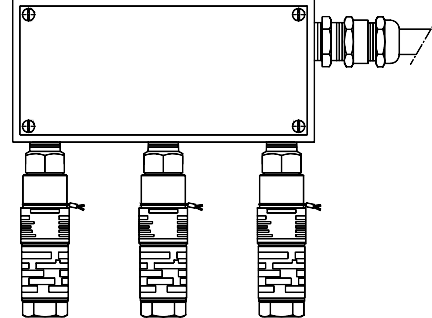

Fig. 11. Example of direct mounting



B-29-E20108AT

Fig. 12. Example of mounting



- 1 – Elbow fitting
- 2 – Blocking joint
- 3 – Three-piece joint
- 4 – Adaptor
- 5 – Drain plug
- 6 – Service valve
- 7 – Tubing
- 8 – Three-piece joint
- 9 – Process piping

- 10 – Root valve with drain
- 11 – Three-piece joint
- 12 – Tee fitting
- 13 – Manifold
- 14 – Ground ring
- 15 – Sleeve