

# CANTY

## PROCESS TECHNOLOGY

## CAMERA SYSTEMS



### HOW IT WORKS

J.M. Canty cameras are patented systems designed to illuminate and view inside a pressure or process vessel through a single connection. There is no need for multiple vessel ports. Canty supplies an integrally mounted camera and lighting system (optional) in a connection as small as a 2" NPT. The industry standard video output can be displayed on a video monitor in the comforts of a control room, or recorded on any VCR. A standard video monitor or TV with video input may be used to display the image.

### CANTY LIGHTS MAKE IT POSSIBLE

The key to Canty Camera/Light combination systems is the Canty light. Canty uses fiber optic light guides to focus cool, effective light into a process vessel or area. Cool light eliminates product bake-over on the viewing window. Fiber optic light guides have been specifically designed to work in conjunction with cool light to maximize the light transmission into the vessel. The resulting live, remote video image from this illumination is unparalleled!

### THE COMPLETE PACKAGE

Canty can meet all your needs! Included as standard equipment on every camera system are power supplies, a high resolution B & W, color or Ethernet camera, pre-focused lens and WP, IP66, explosion proof or flame proof enclosure. What's more – all wiring and maintenance are external. Many optional monitors, recording and control options are available. All cameras can be easily integrated with a Canty Vector System for various process measuring and control functions such as non-contact level control, particle sizing, etc. Please consult the factory for details.

### APPLICATIONS

- Polymers – Verify empty, monitor level
- Crystallizers – Liquid and foam level
- Fermentors – Liquid and foam level
- High purity pharmaceutical applications
- Toxic Material – Remote viewing
- Foam and Fluid Level monitoring in:
  - Shredders
  - Nutsche Filters
  - Strippers
  - Hoppers
  - Latex Applications
  - Pressure Vessels

### FEATURES

- FM, CSA and approvals to CENELEC on various models. World wide approval!
- 10,000 PSI ratings are available
- Up to 2000° F capabilities
- 2" NPT, 2" flange and larger, 2" Tri-Clamp® and larger connections are available.
- High resolution CCD cameras – available in B&W and color, NTSC, PAL and Ethernet output.
- Remotely view your process from the comforts of a control room
- Single nozzle viewing/illuminating (with light)
- Remote light dimming options
- Spray rings are available to keep your window clean

### SPECIFICATIONS

CCD Sensor:	1/2" format. 811(H) x 508(V) typ.
Sensitivity:	Available from .0001 lux usable picture (low light B&W). 0.1 lux is typical (color). Varies with model.
Video Output:	1.0 V p-p, 75Ω typ.(analog) or Ethernet options.
Ambient Temp:	-30°C to 50°C
Current Req.:	500 mA typical
Cable:	RG 59/U, 75Ω coaxial cable suitable CCTV applications (analog) or Cat5e Ethernet (Ethernet Models)
Environmental ratings:	NEMA 4, IP66, Explosion proof (Class 1, Div. 1, Groups B, C & D, Class II, Div. 1, Groups E, F & G) or Flameproof EEx d IIC T6

### OPTIONS

- Vector System - level/foam control, volume control, in-line particle sizing, color analysis
- Time/date generators – overlay time and date stamp onto video picture
- Data overlay – overlay pH, temp, pressure, etc. on-to video picture
- Fiber Optic Link – replaces coaxial cable, need for conduit

**CANTY**

JM Canty Inc | Buffalo, NY USA  
JM Canty Ltd | Dublin, Ireland

Ph: (716) 625 4227

Fax: (716) 625 4228

Ph: + 353 (01) 882 9621

Fax: +353 (01) 882 9622

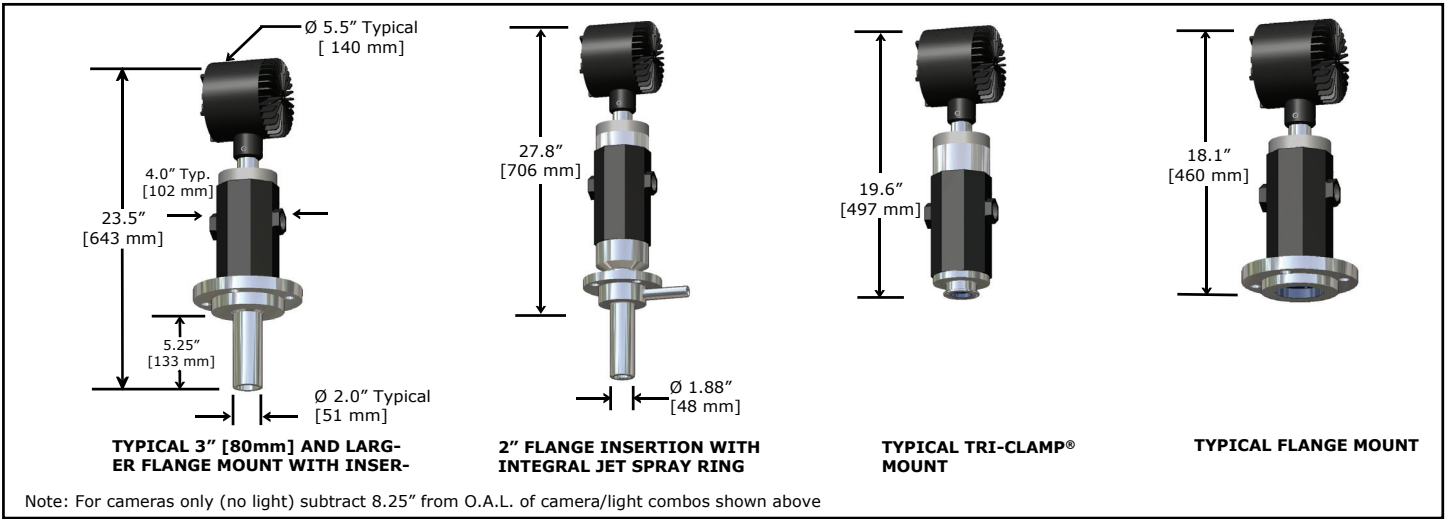

### Ordering Information

HOW TO ORDER: Select the appropriate symbols and build a part number as shown:



#### EXAMPLE:

**V 6 B 2 1 B D 1 J**

#### VISION SYSTEM

- V - North American standard
- VE - European standard

#### ENVIRONMENTAL RATINGS

- 6 - NEMA 4 weather proof, IP66
- 7 - Explosion proof (US) or Flame proof (Europe)

#### CAMERA OPTIONS

- B - B & W camera
- L - Low Light B & W camera
- C - Color camera
- I - Infrared (near) B & W
- E - Ethernet Network Video camera

#### LENS OPTIONS

- (Note: Some lenses are not available with certain mounting connections. Consult your binder for details)
- 2 - 56° (H) x 43° (V) x 69° (D)
  - 3 - 69° (H) x 53° (V) x 80° (D)
  - 6 - 41° (H) x 31° (V) x 50° (D)

#### CAMERA POWER SUPPLY OPTIONS

- 1 - [User supplies 120 V AC. Power supply in a non WP or EXP enclosure. User provides enclosure and switch as needed.](#)
- 2 - No power supply required.
- 5 - [User supplies 120 V AC. Power supply in a WP enclosure.](#)
- 6 - [User supplies 240 V AC. Power supply in an IP/WP enclosure.](#)
- 7 - [User supplies 120 V AC. Power supply in an EXP enclosure. PSU enclosure is rated Class I, Div 1, Groups C & D.](#)
- 8 - [User supplies 240 V AC. Power supply in non WP or FP enclosure. User provides enclosure and switch as needed.](#)

#### WETTED MATERIAL OPTION

- B - 316 L Stainless Steel\*
- D - Hastelloy® C-276 or equal
- E - Hastelloy® C-22® or equal
- F - Glass (BoroPlus™)\*\*

\*Canty reserves the right to upgrade to Hastelloy® C family of alloys or equal at their own cost  
 \*\* Not available with all models

#### LIGHT OPTIONS

- G - HYL 80 1SRDO (240 V)
- J - HYL 80 1SRDO (120 V)
- N - Camera only - will not accept an integral light
- 0 - Combo w/o light - will accept an existing light (Note: Without a light source the camera cannot maintain WP or EXP integrity)

#### NON WETTED MATERIAL

- 0 - No flange required (if selecting a flanged model). Select this option when choosing NPT or Tri-Clamp® models also.
- 1 - 150 # carbon steel ANSI flange
- 2 - 150 # 316L stainless steel ANSI flange
- 3 - 300 # carbon steel ANSI flange
- 4 - 300 # 316L stainless steel ANSI flange
- 6 - 16 Bar carbon steel DIN flange
- 7 - 16 Bar stainless steel DIN flange
- 8 - 10 Bar carbon steel DIN flange
- 9 - 10 Bar stainless steel DIN flange

#### MOUNTING CONNECTION

- Consult factory for additional sizes and ratings.
- B - 2" NPT, 5.25" insertion
  - C - 3" ANSI flange
  - D - 4" ANSI flange
  - E - 2" ANSI flange
  - F - 3" ANSI flange, 5.25" insertion
  - G - 100 mm DIN flange
  - H - 4" ANSI flange, 5.25" insertion
  - J - 100 mm DIN flange, 5.25" insertion
  - K - 2" ANSI flange, 5.25" insertion
  - M - 3" Tri-Clamp® 5.25" insertion
  - P - 4" Tri-Clamp® 5.25" insertion
  - Q - 80 mm DIN flange
  - S - 80 mm DIN flange, 5.25" insertion
  - T - 2" ANSI flange, 5.25" insertion w/integral spray ring
  - U - 4" Tri-Clamp®
  - 2 - 2" Tri-Clamp®
  - 3 - 3" Tri-Clamp®
  - 5 - 6" ANSI flange, 5.25" insertion

**CANTY**

JM Canty Inc | Buffalo, NY USA | Ph: (716) 625 4227 | Fax: (716) 625 4228  
 JM Canty Ltd | Dublin, Ireland | Ph: + 353 (01) 882 9621 | Fax: +353 (01) 882 9622

[www.cantylight.com](http://www.cantylight.com)