

CANTY

PROCESS TECHNOLOGY

ULTRATEMP™ HIGH TEMPERATURE CAMERAS

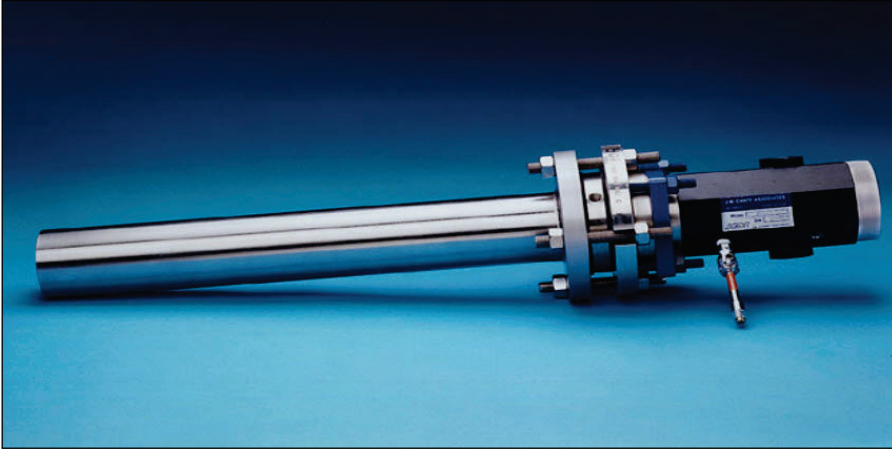

UNMATCHED PERFORMANCE

Canty ULTRATEMP™ Cameras are ideal for demanding applications involving visual inspection or verification in extreme temperature environments.

- Computer designed optics for a crystal-clear picture.
- All cameras feature state of the art camera technology.
- A digital electronic auto-iris provides an exceptional image of your application without the problems associated with manual apertures.
- High temperature lenses designed to survive in process without cooling air.

SAFETY IS A PRIMARY CONCERN

Canty ULTRATEMP™ Camera Systems feature a fused glass seal standard with every model. This unique seal provides an impenetrable safety barrier to protect the camera electronics from the harsh process environment and preventing hazardous vapors from escaping into your plant.

NO LENS AIR PURGING REQUIRED

Unlike other manufacturers, Canty does not require air to keep the lenses cool.

Loss of air will not destroy our camera system!

A positive air flow is used for maintenance purposes only to keep dust and soot from accumulating on the lens.

As a result, many applications will not require any air purge, which can save thousands of dollars per year!

APPLICATIONS

- Furnaces
- Power Boilers
- Black Liquor Recovery Boilers
- Incinerators
- Kilns
- Melting Chambers

FEATURES

- No cooling air required. Air is used for cleaning only!
- Disposable Quartz Protective Shield
- High Temperature Furnace Lens - Models Up To 2500°F
- Auto Electronic Iris
- High Quality Quartz Optics
- Fused Glass Seal Separates Electronics From Process
- Insertion Lens Available Up To 36" Long
- Non-Blooming CCD Cameras

SPECIFICATIONS

Video Formats: NTSC, PAL, EIA, CCIR, or Ethernet outputs available.

Video Output: 1.0 V p-p, 75 ohm(NTSC, PAL, EIA, CCIR models) or Ethernet output to PC available

Cable: RG 59/U, RG 11/U, RG 6/U coaxial cable suitable for CCTV applications is recommended for analog cameras. Ethernet cameras require CAT5e or better cabling.

Power Req.: User supplies 120V AC, 60 Hz or 230V AC, 50 Hz power. Canty supplies transformer To 12V DC, .5A TYP.

Ratings: Available in NEMA TYPE 1, NEMA TYPE 4, IP20, IP66

Mounting: 3" 150# ANSI or 80 mm DIN flange for Flush Mount units. Insertion units require a Ø3.5" hole that the wall mount tube will insert into and be welded to.

CANTY

JM Canty Inc | Buffalo, NY USA
JM Canty Intl Ltd | Dublin, Ireland

Ph: (716) 625 4227
Ph: + 353 (01) 882 9621

Fax: (716) 625 4228
Fax: +353 (01) 882 9622

www.jmcanty.com

DIMENSIONAL INFORMATION

Insertion sizes 12" and Larger

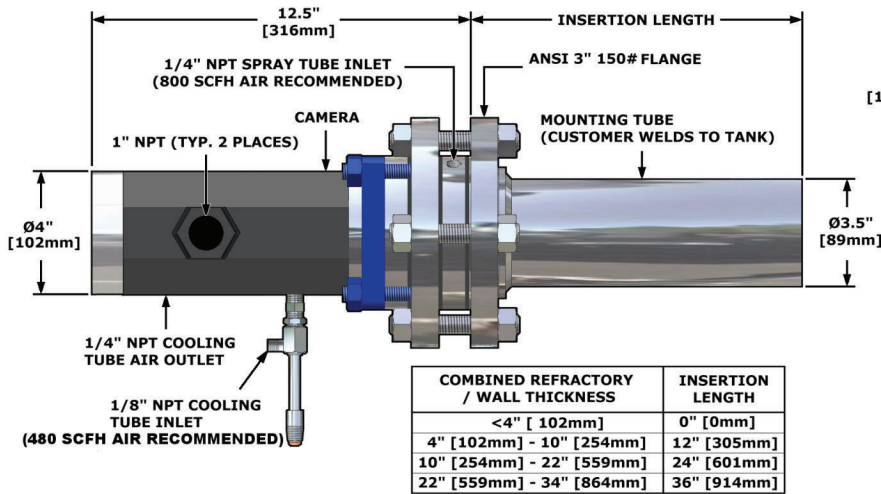

Non Insertion Models

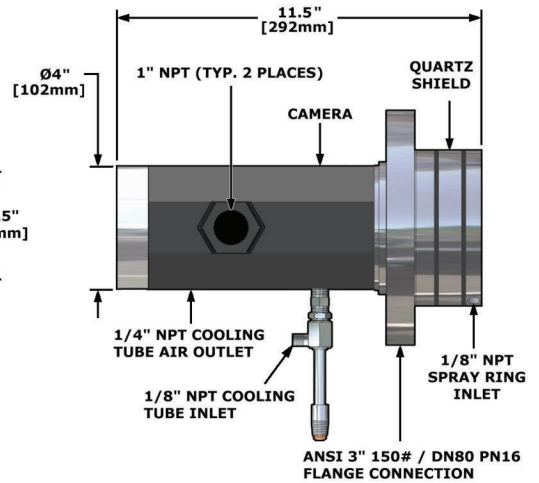

- For 0" Insertion models, customer must provide a 3", 150# ANSI (U.S.) or DN80 PN16 (Europe) flange connection to mount camera.
- For all other insertion lengths, customer must provide a 3.5" [89 mm] diameter mounting hole to weld Cauty supplied mounting tube to furnace.
- Layout drawings and additional insertion lengths available. Consult factory.

Ordering Information

HOW TO ORDER: Select the appropriate symbols and build a part number as shown:

EXAMPLE:

VSH DC 6 6 C 1 - S - 3FL150S - 24INS

VIDEO OUTPUT FORMAT

VSH - North American Standard
VEH - European Standard

CAMERA OPTION

DL - B&W camera
DC - Color camera
DE - Ethernet camera
DR - Near IR Ethernet camera

ENVIRONMENTAL RATING

6 - Weather Proof

TEMPERATURE RATING

5 - Furnace operating 2000°F
Temp at lens 1300°F (No insertion)
6 - Furnace operating 2000°F
Temp at lens 1300°F (Insertion models)
7 - Furnace operating 2500°F
Temp at lens 1600°F (Insertion models)

Note: For higher temperature requirements, see the EXTREME^{TEMP}™ model: TA10889-1.

LENS VIEW ANGLES

Insertion Models

B - 30°(H) X 22°(V)
C - 45°(H) X 34°(V)
D - 65°(H) X 49°(V)

Non-Insertion

E - 7°(H) X 5°(V)
F - 22°(H) X 16°(V)
G - 41°(H) X 31°(V)
H - 69°(H) X 53°(V)

INSERTION LENGTHS

0INS - Flush Mount - No Insertion
12INS - 12" [305mm] Insertion
24INS - 24" [610mm] Insertion
36INS - 36" [914mm] Insertion

MOUNTING CONNECTION

3FL150S - 3" 150# ANSI Flange Mount
80FL16S - 80mm 16 Bar DIN Flange
(option for flush mount only)

MATERIAL OF CONSTRUCTION

S - 304 L Stainless Steel
H - Hastelloy® C276

CAMERA POWER SUPPLY OPTIONS

- 1 - [Power supply in NEMA Type 1 enclosure \(120V AC input\)](#)
- 2 - [Power supply in IP 20 enclosure \(230V AC input\)](#)
- 5 - [Power supply in WP NEMA 4X enclosure \(120V AC input\)](#)
- 6 - [Power supply in IP66 enclosure \(230V AC input\)](#)

NOTE: Accessory Kit part number: V401-KIT available to aid in installation contains 100-1000 SCFH and 60-600 SCFH Flowmeters along with a 0.5 micron oil/vapor removal filter.



www.jmcanty.com
Document P/N : TA7355-I Rev. 8

JM Cauty Inc

Buffalo, NY USA

Ph: (716) 625 4227

Fax: (716) 625 4228

JM Cauty Intl Ltd

Dublin, Ireland

Ph: + 353 (01) 882 9621

Fax: +353 (01) 882 9622

All registered trademarks are the property of their respective owners.